

COMMUNITY DEVELOPMENT CODE

Article 50. Appendix

TABLE OF CONTENTS

Sections:

50.Appendix.50.00	Preface.
50.Appendix.50.02	Definitions.
50.Appendix.50.02-A	Measurement of Building Height - Reference Point.
50.Appendix.50.02-B	Lot Depth and Lot Lines.
50.Appendix.50.02-C	Side-Loading Garage.
50.Appendix.50.06	Residential Medium & High Density R-0, R-2, R-3, R-5, and WR Zones.
50.Appendix.50.06-A	Height Exceptions.
50.Appendix.50.07	Residential - First Addition District (R-6) Zone.
50.Appendix.50.07-A	Primary and Secondary Roofs.
50.Appendix.50.07-B	Yard Setbacks.
50.Appendix.50.07-C	Front Setback Plane.
50.Appendix.50.11	Commercial Zones.
50.Appendix.50.11-A	Floor Area Ratio Graph.
50.Appendix.50.11-B	Commercial Land Use Policies.
50.Appendix.50.12	Campus Institutional Zone.
50.Appendix.50.12-A	Marylhurst Campus Institutional Area.
50.Appendix.50.13	Industrial Zones.
50.Appendix.50.13-A	Industrial Land Use Policy Element.
50.Appendix.50.16	Sensitive Lands Overlay Districts.
50.Appendix.50.16-A	Lake Oswego Resource Areas Report.
50.Appendix.50.16-B	Delineating Stream Corridors.
50.Appendix.50.16-C	Oswego Canal.
50.Appendix.50.21	Vision Clearance.
50.Appendix.50.21-A	Vision Clearance Triangle.
50.Appendix.50.22	Exceptions to Site Development Standards and Special Determinations.
50.Appendix.50.22-A	Measurement of Oswego Lake Setback.
50.Appendix.50.44	Flood Management Area.
50.Appendix.50.44-A	Lake Oswego Flood Management Area Map.
50.Appendix.50.55	Parking Standards.
50.Appendix.50.55-A	Minimum Off-Street Parking Space Requirements.
50.Appendix.50.55-B	Off-Street Parking Matrix.
50.Appendix.50.55-C	Parking Requirement Modifiers.
50.Appendix.50.55-D	Minimum Required Bicycle Parking Spaces.
50.Appendix.50.60	Local Street Connectivity.
50.Appendix.50.60-A	Local Street Connectivity.
50.Appendix.50.65	Downtown Redevelopment District Design Standards.
50.Appendix.50.65-A	Redevelopment Area Boundary Map and Arts & Crafts Style Description.
50.Appendix.50.66	Old Town Neighborhood Design Standards.
50.Appendix.50.66-A	Old Town Styles Description.
50.Appendix.50.67	West Lake Grove Design District Standards.
50.Appendix.50.67-A	West Lake Grove Design District Standards.

COMMUNITY DEVELOPMENT CODE

Chapter 50 - Appendix

Section 50.Appendix.50.00 Preface.

The Community Development Code Appendix includes all amendments codified through Ordinance No. 2447, effective March 9, 2006.

The Community Development Appendix has also been converted into Adobe Acrobat PDF format and can be viewed on the city's website by clicking the menu for "Forms & Documents", Community Development Code located at <http://www.ci.oswego.or.us>.

Note: you must have the Adobe Acrobat reader installed on your computer in order to view the Appendix in PDF format. The Adobe Acrobat reader can be downloaded free from Adobe.



Acrobat and the Adobe Logo are trademarks of Adobe Systems Incorporated

APPENDIX 50.02

DEFINITIONS

Appendix 50.02-A

Measurement of Building Height – Reference Point

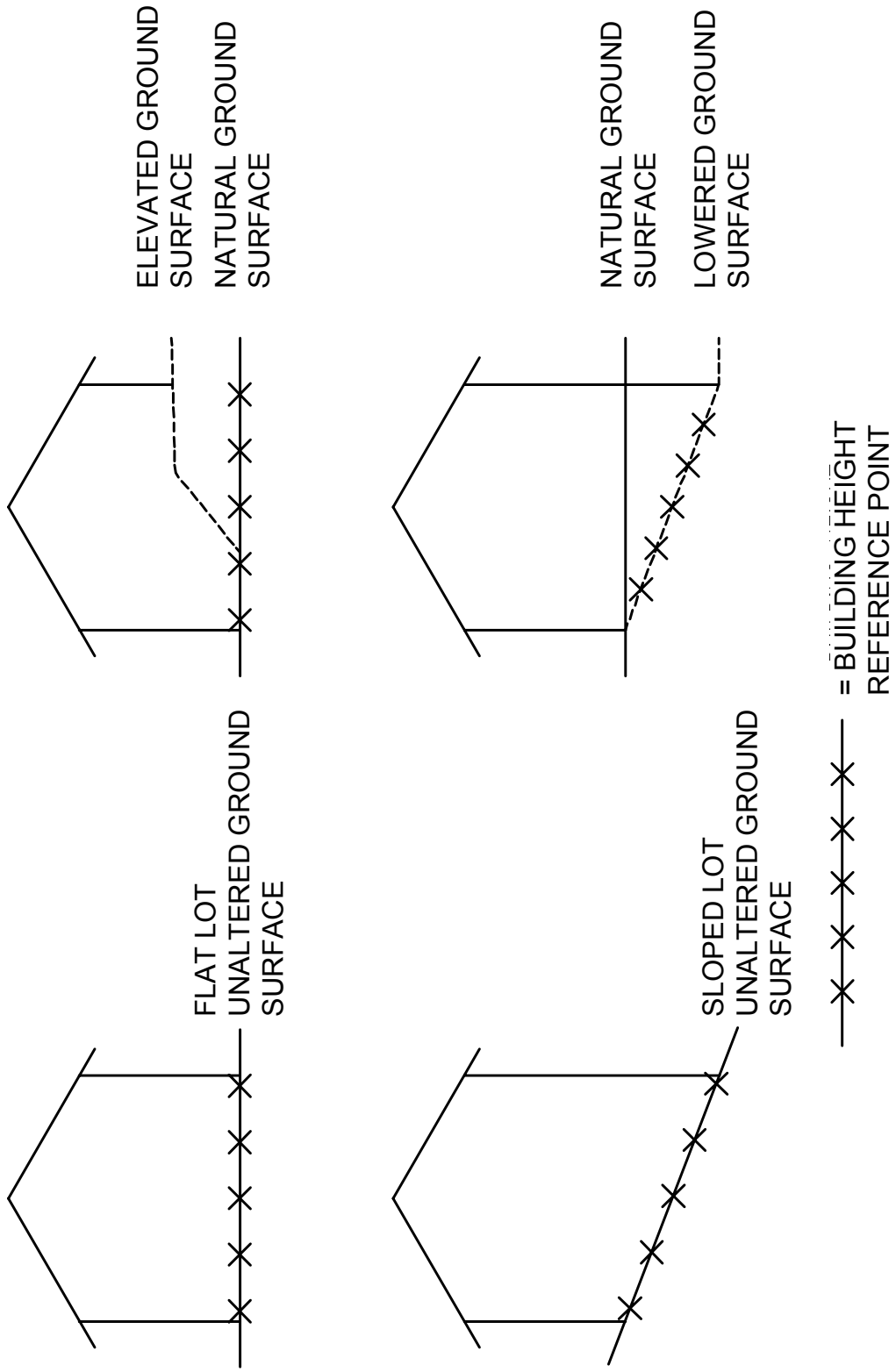

Appendix 50.02-B

1. Lot Depth

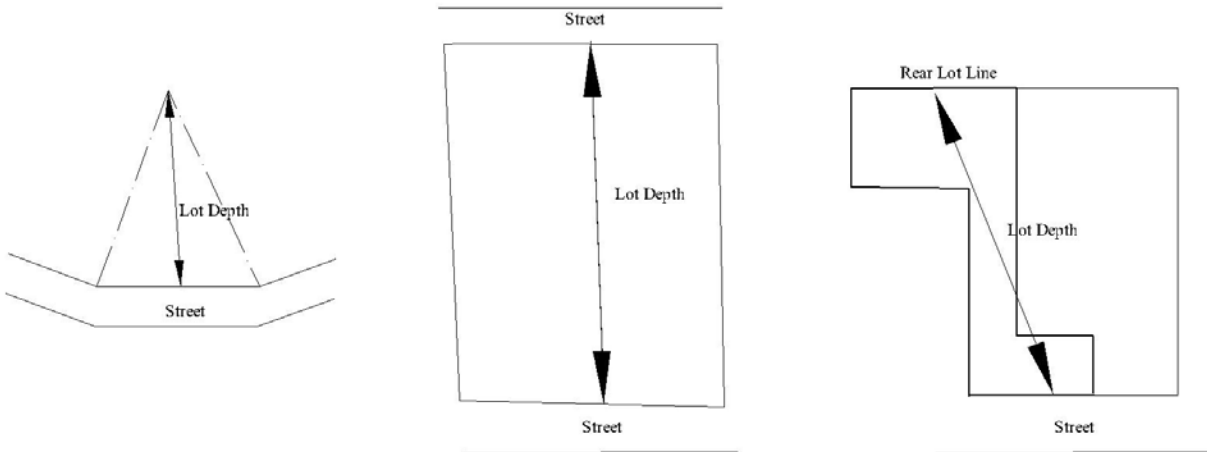

Triangular Lot

Through Lot

Non-Rectangular Lot

2. Lot Lines, Rear.

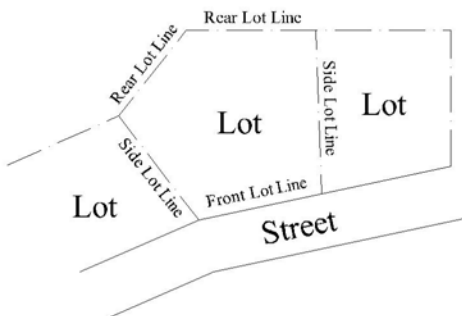

Irregular Lot

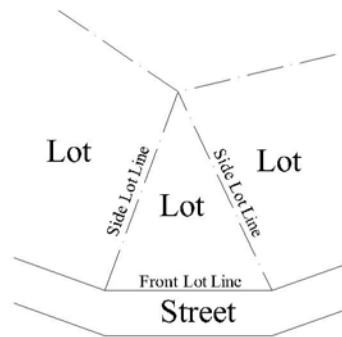

Triangular Lot

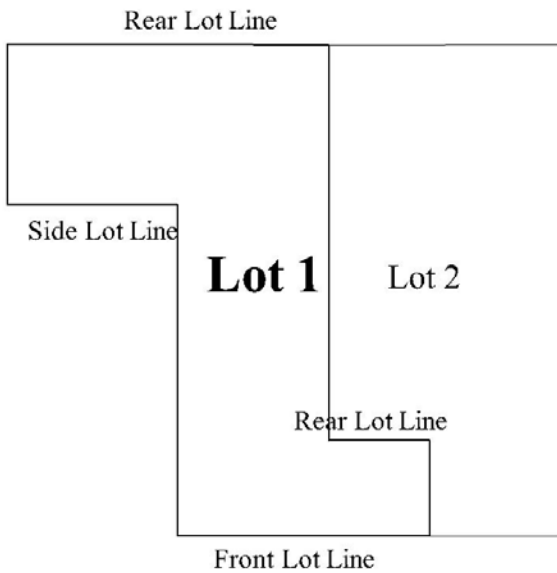

Non-Rectangular Lot

Lot 1

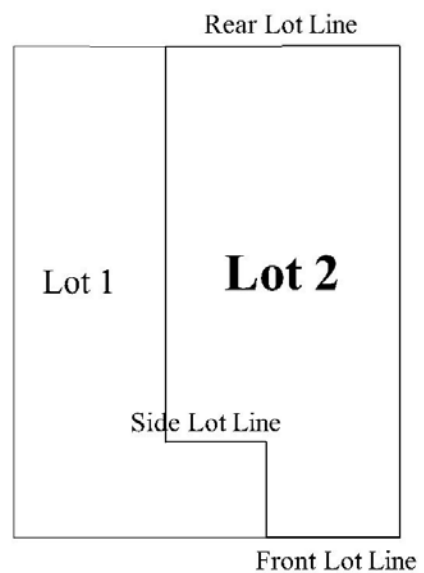

Lot 2

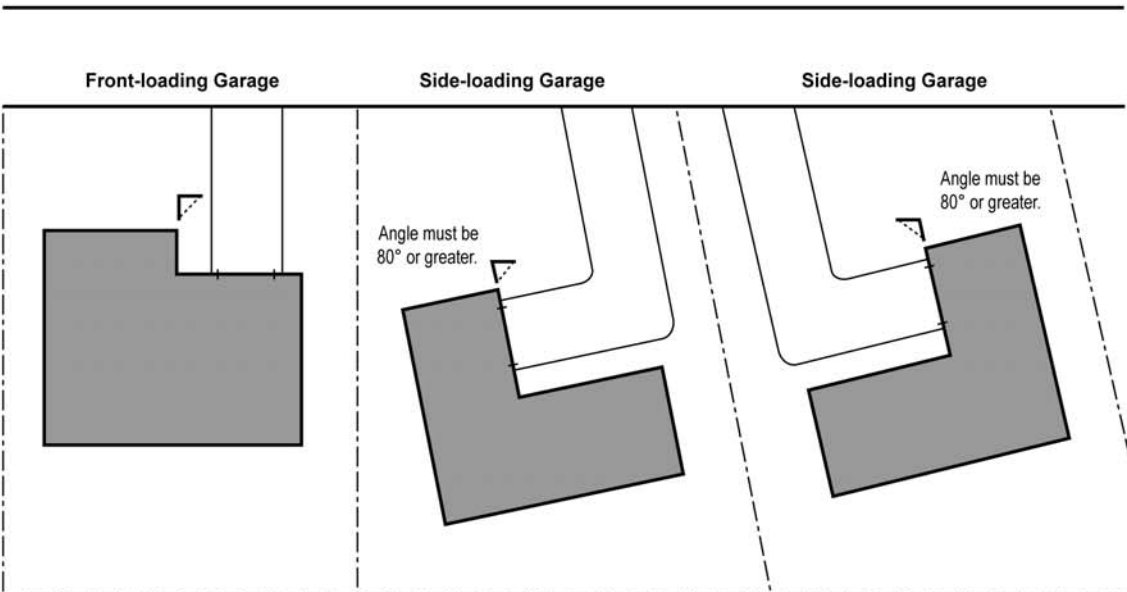

Examples of side-loading garages -
garage doors face a minimum of 80° away from the street.

Appendix 50.02-C
Side-loading Garage

APPENDIX 50.06
RESIDENTIAL MEDIUM & HIGH DENSITY
R-0, R-2, R-3, R-5, AND WR ZONES

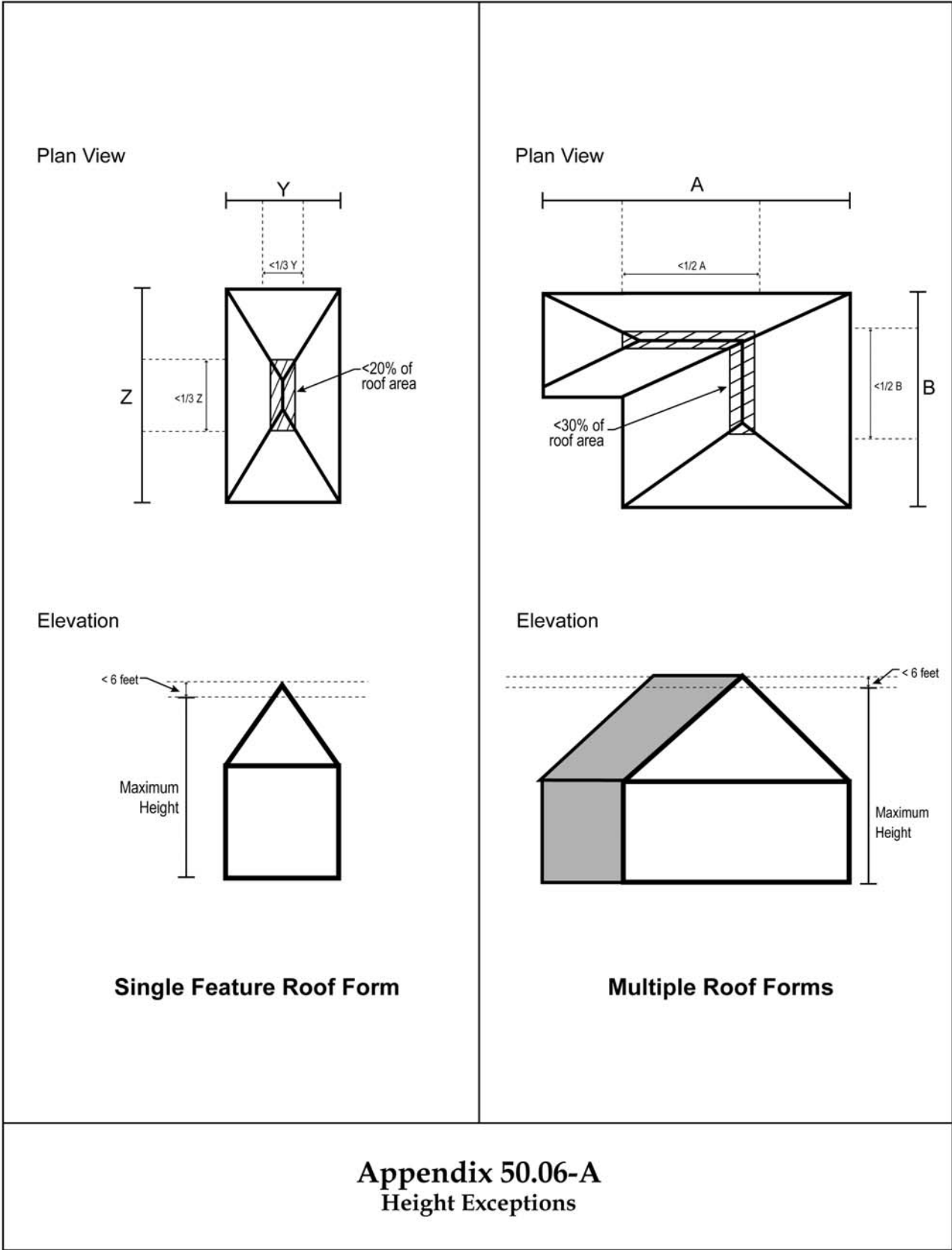

(Ord. 2398, Added, 12/06/2005)

APPENDIX 50.07
RESIDENTIAL – FIRST ADDITION DISTRICT
(R-6) ZONE

Appendix 50.07 - A

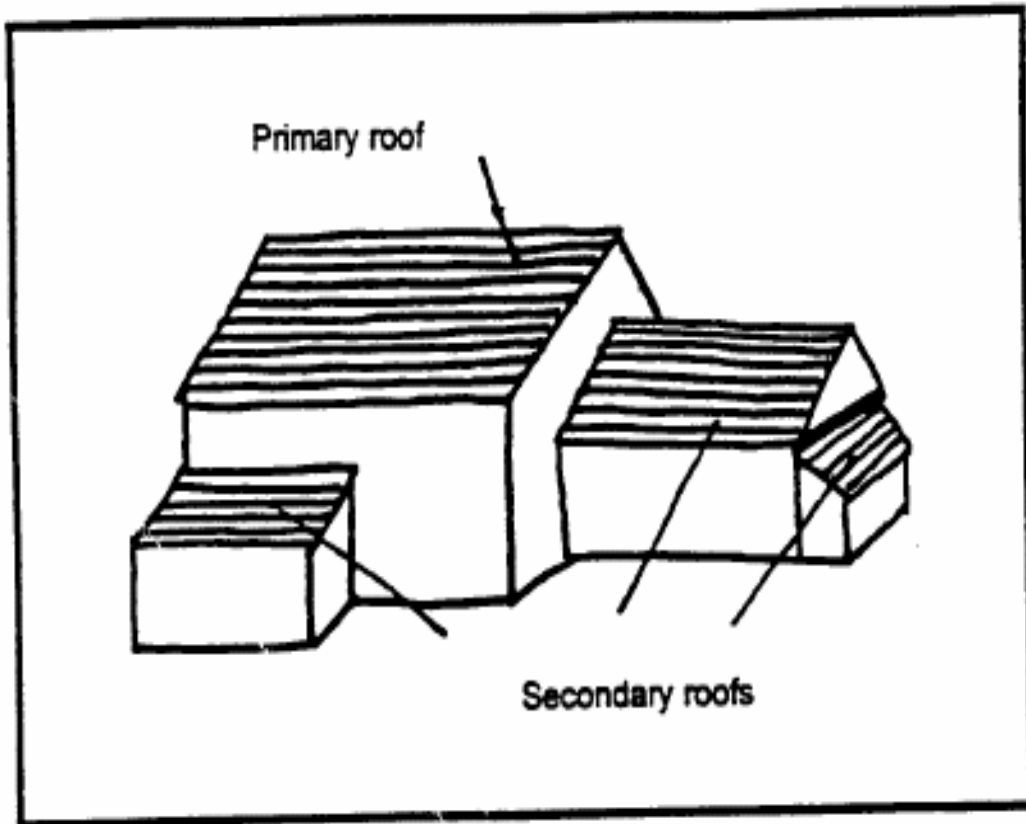

Appendix 50.07-B

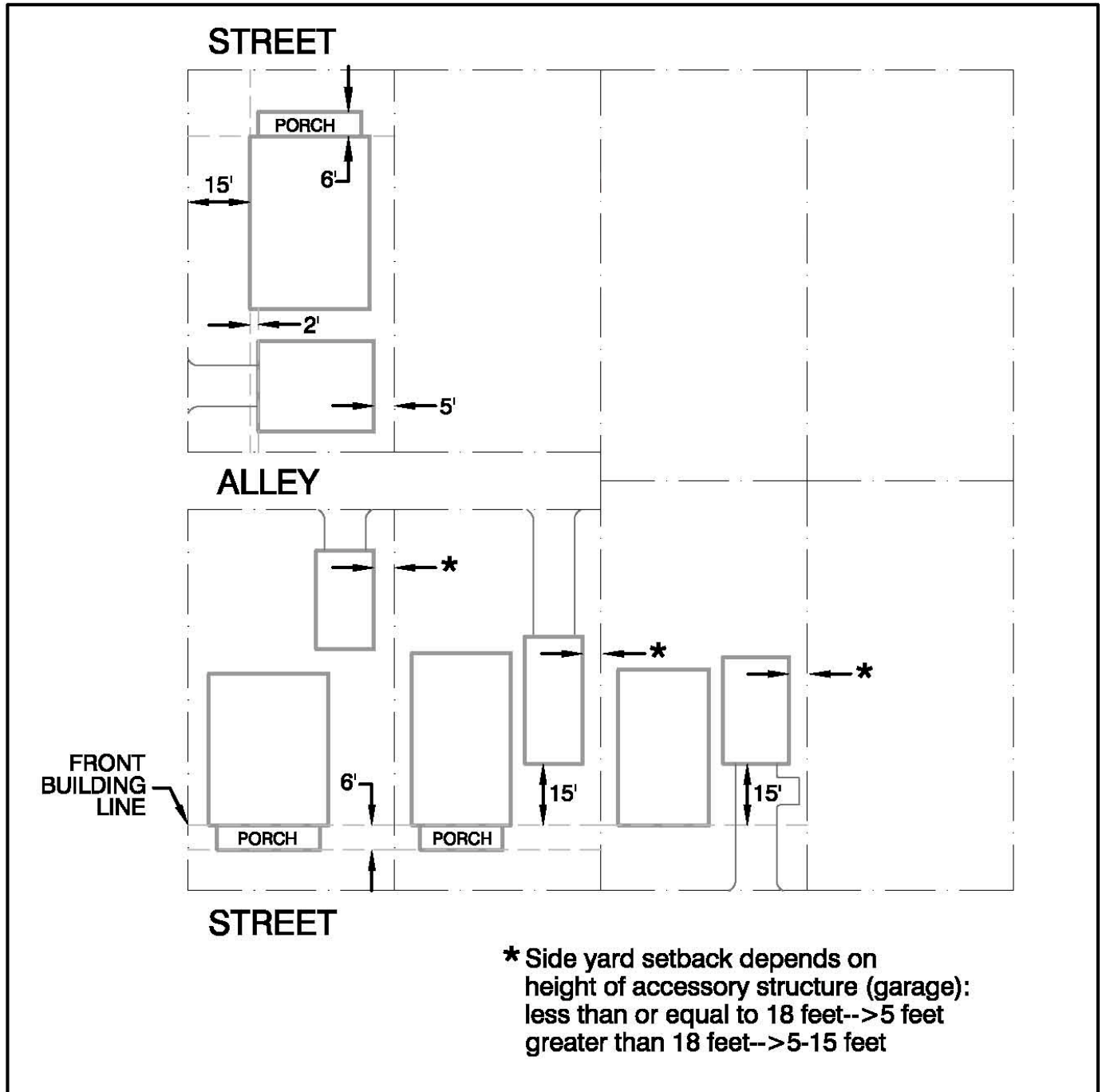

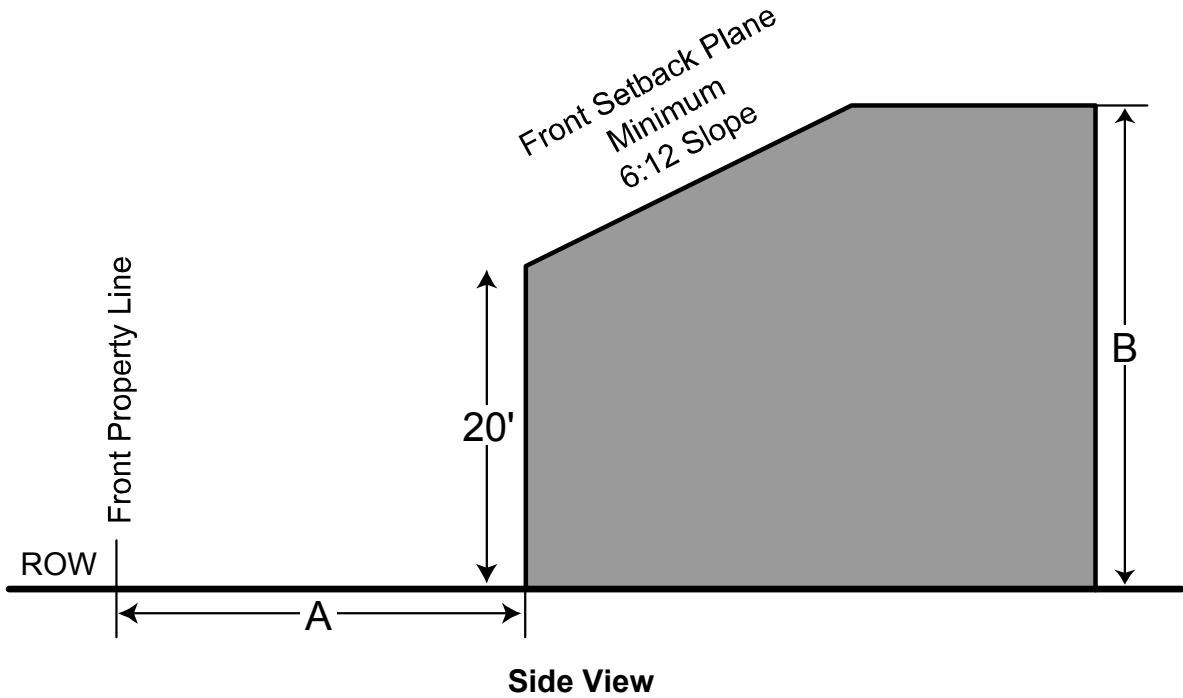

Legend

Permitted Building Envelope
 A Front Yard Setback
 B Maximum Building Height

**Appendix 50.07-C
Front Setback Plane**

February 2004, SCM/City of Lake Oswego

**APPENDIX 50.11
COMMERCIAL ZONES**

Appendix 50.11 - A

FLOOR AREA RATIO GRAPH

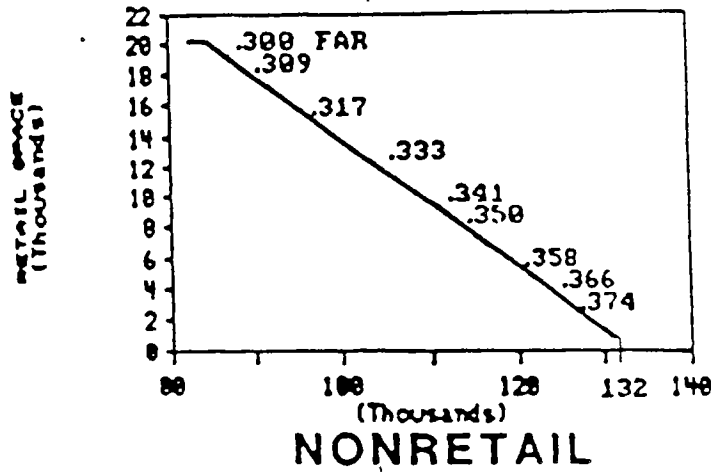

RETAIL	NONRETAIL	FAR
0	133091	0.308
1000	130482	0.309
2000	128272	0.317
3000	125863	0.333
4000	123454	0.341
5000	121044	0.350
6000	118635	0.358
7000	116226	0.366
8000	113817	0.374
9000	111407	
10000	108998	
11000	106589	
12000	104179	
13000	101770	
14000	99361	
15000	96951	
16000	94542	
17000	92133	
18000	89723	
19000	87314	
20000	84905	
20750	82495	

COMMERCIAL LAND USE POLICIES

OBJECTIVE: TO ENCOURAGE DEVELOPMENT OF COMMERCIAL FACILITIES ADEQUATE TO SATISFY COMMUNITY NEEDS AND TO FOCUS SOCIAL INTERACTION AND COMMUNITY IDENTITY IN CONJUNCTION WITH THOSE COMMERCIAL FACILITIES.

GENERAL POLICIES

- I. The City will encourage development of commercial areas to meet the community's consumer needs.
- II. The City will plan for a mix of social, cultural, commercial, and governmental activities within commercial centers, so that these centers are attractive community focal points.
- III. The City will plan for the development of commercial districts scaled in size to the area to be served.
- IV. The City will assure provision of adequate streets, public facilities and consistent governmental policies, which will encourage private investment in the development of Lake Oswego's commercial centers.
- V. The City will assure minimal negative impacts of commercial development on adjacent residential areas.

Specific Policies

For General Policy I: Encourage development of commercial areas to meet the community's consumer needs.

The City will:

1. Limit the amount of commercial land to that needed to serve the expected population at full development, in an amount which will:
 - promote revitalization of existing business districts
 - provide for proportional increases in commercial space as population increases
 - encourage investment in new commercial facilities
 - reduce length and number of vehicle shopping trips
 - create minimum intrusion into residentially developed neighborhoods
2. Maps for the planned commercial land areas appear on following pages.
3. Encourage more intense land coverage and pedestrian circulation within commercial areas.

For General Policy II: Plan for commercial centers as community focal points.

The City will:

1. Plan land use patterns which will guide commercial and service activities into groups of establishments, which will be mutually supporting and convenient to the public.
2. Prevent additional strip development along arterials and make provisions for parking, rear access and redevelopment, to minimize the negative impact of existing strip development.
3. Adopt design policies which encourage site plans which are in keeping with the general character of the community, and which will make sound healthy business centers.

4. Encourage development of the East End Commercial District and the West End Commercial District as centers of commercial and social activity and employment opportunities.
5. Encourage a mix of residential, commercial and service activities in commercial centers.
6. Encourage the development of intra-city transportation alternatives (such as mass transit) to serve the commercial centers.

For General Policy III: Plan for the development of commercial districts scaled in size to the area served.

The City will:

1. Develop Commercial District Policies which outline the objectives, specific policies and strategies which will guide development in each Commercial District, including:
 - East End Business District
 - West End Business District
 - Mt. Park "Town Center" site
 - Monroe/Boones Ferry site
 - I-5/Kruse Way Highway Commercial/Kruse Way Campus Research and Development
 - Grimm's Corner Neighborhood Commercial
 - Rosewood Neighborhood Commercial
 - Kruse-North Neighborhood Commercial
 - Other Commercial sites in Mt. Park
2. Include in Commercial District Policies:
 - a. identified service area, where applicable.
 - b. gross leasable sq. ft., building coverage or Floor Area Ratio desirable
 - c. land area designated commercial for full development
 - d. standards to apply to zone changes, include:
 - necessary on-site circulation pattern
 - site and building design criteria to fulfill community policies
 - location criteria for access to streets and parking and public transportation
 - e. type of activities desirable (e.g. comparison or convenience shopping)
3. Make zone changes subject to conditions which meet the Commercial District Policies, including preservation of the capacity of streets and intersections.

For General Policy IV: Encourage private investment in planned commercial centers.

The City will:

1. Provide public facilities plans and development policies which will encourage:
 - a. revitalization of the east end commercial area
 - b. revitalization of the west end commercial area
 - c. neighborhood commercial centers which maximize the advantages and minimize the disadvantages of neighborhood living adjacent to commercial activity
 - d. development of the "Town Center" site compatible with community goals and street system
 - e. development of highway oriented commercial facilities at I-5 and Kruse Way which are compatible with community goals and street system
 - f. private investment in shared parking and access facilities

2. Provide incentives which encourage developers to renovate and expand existing buildings, compatible with community policies such as:
 - a. decrease on-site parking requirements if equivalent public parking is available.
 - b. re-define landscaping requirement, to include street trees, bike paths, public benches, conversation spots or other publicly desired amenities
 - c. allow waiver of height restrictions when appropriate
 - d. encourage two level parking facilities where appropriate
 - e. revise fire code standards to encourage commercial development in keeping with city revitalization policies as well as safety.
3. Establish a development corporation to encourage continuing vitality in the commercial area. The corporation could:
 - a. enable cooperative planning, problem solving, and investment
 - b. enlist community support
 - c. encourage private investment
 - d. seek public funds (federal, state and local)

For General Policy V: Assure minimum commercial intrusion on residential areas.

The City will:

1. Develop a major street network which minimizes through traffic on neighborhood streets.
2. Locate commercial activity on collector and arterial streets only and consider traffic impacts prior to siting new commercial activities.
3. Design and construct commercial development to minimize the impacts on residential areas from traffic, lights, visual appearance of parking and loading areas, building bulk and height, noise and drainage. Such means as landscaping, berms, fencing, trees, open space, cul-de-sacs, building orientation, lower intensity of commercial uses (e.g., offices) should be utilized.
4. Where feasible, pedestrian and bikeway paths should connect commercial development with adjacent residential areas.

Specific Policies

SPECIFIC COMMERCIAL DISTRICT POLICIES

For General Policy III: Plan commercial districts scaled in size to the area served.

In order to assure development of commercial districts in accord with policies set forth in this Plan, Commercial District Policies are defined as Specific Policies to implement the Comprehensive Plan. These specific Commercial District Policies will be implemented by Development Conditions attached to all commercial zone changes, and through Development Conditions attached to Development Review and building Permit approval.

Specific Commercial District Policies are outlined for the following Commercial Districts:

- I. East End Community Business District and Subarea
 - a. Existing East End Community Business District
 - b. Riverfront Subarea (PA 06-86-02-383, 10/17/86)
- II. Grimm's Corner Neighborhood Commercial District
- III. Rosewood Neighborhood Commercial District

Revised 10/86

- IV. West End Community Business District and sub areas:
 - a. Existing West End Business District
 - b. Oakridge Mixed Use Area
 - c. Bryant to Reese, North of Sunset
 - d. Southwest Quadrant of Kruse Way/Boones Ferry Intersection
 - e. Office Campus Northwest Quadrant of Kruse Way/Boones Ferry Intersection
 - f. East Side of Boones Ferry Road at Kruse Way
- V. Highway Commercial District and CR&D, Kruse Way Area:
 - a. Northeast Quadrant
 - b. Bangy Road
 - c. CR&D, South of Kruse Way
- VI. Kruse Way North Neighborhood Commercial District
- VII. Mountain Park Commercial Areas
 - a. Mt. Park Town Center Site
 - b. Monroe/Boones Ferry site
 - c. Other Mt. Park commercial and office sites
- IA. East End Community Business District (PA 06-86-02-383, 10/17/86)

Lake Oswego's Central Business District has traditionally been the focal point of the community, as the location of City Hall, commercial shopping, Fire Department, and banking; the Library, Post Office and Adult Community Center have been located near this commercial district, focusing community identity. The streets of this business district have also served as major routes for commuter traffic, to and from Portland.

In recent years, traffic congestion has increased, causing problems for neighborhood residents and for business owners. Citizens and City officials have established goals to encourage revitalization of the business district, to solve the State Street traffic problem, and to assure the residential living environment of adjacent neighborhoods. To carry out these goals and policies in the East End Community Business District, the City will:

1. Provide for a 5.52 acre expansion of the East End Community Business District. This expansion will be maximum district expansion and will be limited on the north by "C" Street, on the west by the alley between Fifth and Sixth, and include land bounded by Fourth, Evergreen and Third, except that major developments fronting State Street and abutting the Old Town Design District may be allowed necessary minimal expansion to the east, but only in accord with conditions set forth in the Old Town Design District Policies. (PA 5-84-151)

Revised 10/86

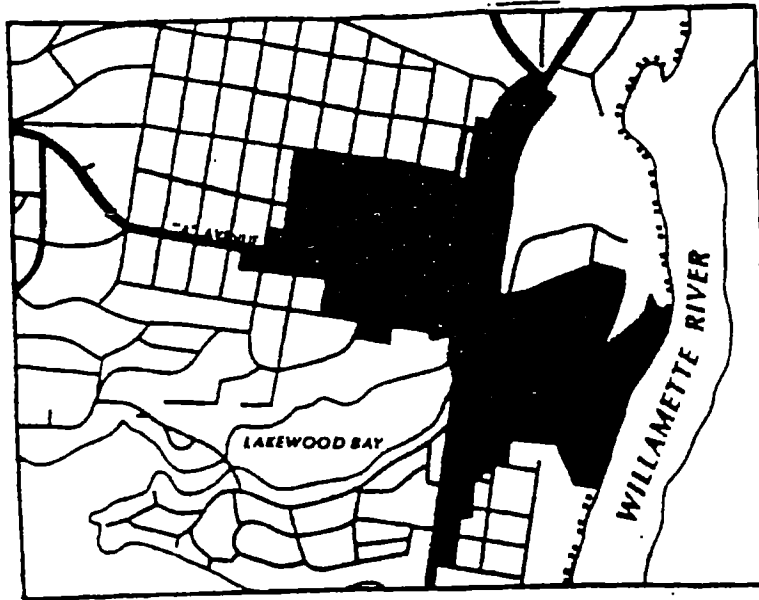

East End Commercial District

2. Develop, adopt and implement an East End Business District Revitalization Plan. This action plan will be developed jointly with private business interests, the City, the Chamber of Commerce, and the Lake Oswego Development Corporation and should include:
 - a. steps necessary to prevent deterioration and encourage redevelopment
 - b. methods to implement solutions already proposed in previous studies, both short range solutions to be implemented immediately, and long range solutions
 - c. the involvement of property owners and the City, in stimulation of private investment
 - d. criteria for the intensification of commercial activity in appropriate locations (see Design Standard, Specific Policy 9 and 10)
 - e. a schedule for provisions of needed public improvements, including traffic and parking improvements, pedestrian facilities, street trees
 - f. criteria for re-examination of commercial requirements, should a substantial portion of present commercial land located east of State Street be eliminated from commercial use, or should industrial area use change
 - g. as re-development occurs on State Street and "A" Avenue, encourage development to re-orient toward alleys and interiors of blocks

3. Plan for adequate delineation of adjacent residential neighborhoods to enhance living environment and neighborhood stability. This includes the following:
 - a. peripheral traffic circulation plan which separates commercial and through traffic from residential neighborhood
 - b. specific land use designations and district boundaries, which specify allowed uses and densities, adopted as part of the Comprehensive Plan
 - c. means to provide separation of incompatible uses, which will be developed as conditions of zone change, conditional use, and Development Review approval, such as:

- i. tree planting, hedges, fences, walls or open space
 - ii. walkways and alleys
 - iii. landscaped parking lots
- d. restriction of new commercial uses on the west side of Fifth Street and the south side of "C" Street to non-retail commercial
 - e. means to buffer residential properties from the noise, glare and visual appearance of commercial activity (both residential and commercial property owners will be encouraged to use landscaping and site design to screen residential property from commercial activities)
 - f. considering commercial uses in residential zones to be nonconforming uses
 - g. see Residential Policies

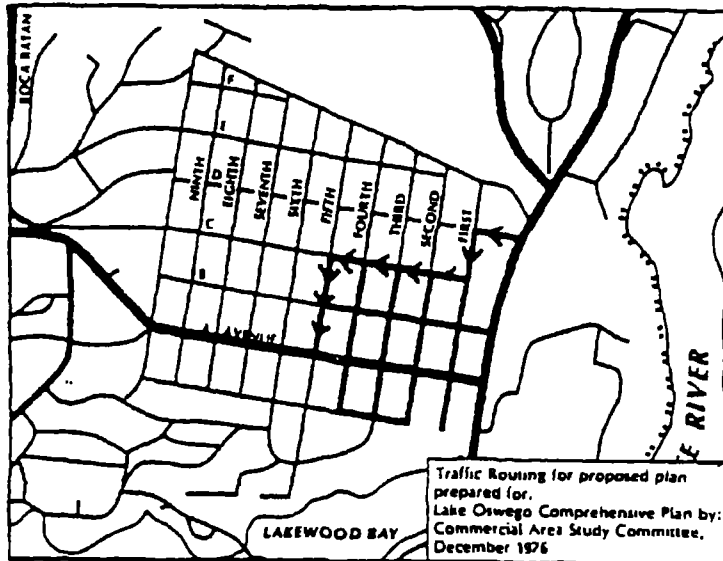

**East End Community Business District
Through Traffic Routes**

- 4. Develop a peripheral street circulation pattern, to guide shoppers to and from the commercial area and into appropriately sited parking facilities. This circulation pattern will include the following components:
 - a. peripheral street circulation pattern, which will:
 - i. define and limit the commercial district to the squared configuration
 - ii. allow convenient vehicular access to parking in all areas of commercial district
 - iii. provide uncongested access from the commercial district into through streets
 - iv. include necessary measures to protect neighborhood streets from through traffic route southbound to westbound through traffic as follows: west from State into "D" to First, then south to "C", up "C" to Fifth Avenue and south into "A" Avenue (see Through Traffic Routes)
 - v.
- 5. Encourage the development of an interconnecting network of bicycle and pedestrian ways, to encourage shoppers to leave their cars and circulate easily among shops, restaurants, cultural and civic activities. This network could include:

- a. covered walkways and mid-block pedestrian paths where feasible
 - b. alleys as paths, places for benches, outdoor eating, kiosks, and landscaping
 - c. bike racks and lockups, covered where feasible
 - d. sidewalk extensions (using up to eight feet of parking lane at street corners) to decrease street width pedestrians must cross
 - e. stairways or possible elevated streets crossings, to connect adjacent properties which are at different elevations.
6. Develop a traffic engineering plan incorporating appropriately located parking facilities, to assure that State Street can best handle expected future traffic. This plan will include at least the following:
- a. State Street as a five-lane street with center lane designated as a left turn sanctuary
 - b. traffic signalization system, programmed for maximum flow of traffic on major streets during peak hours
 - c. widening of Oswego Creek Bridge to handle through traffic in each direction
 - d. removal of all parking from State Street
 - e. additional parking lot space of equal the number of spaces removed from State Street, North Shore to "B" Avenue (See Parking Facility Policies, following)
 - f. parking spaces sited conveniently to State Street between:
 - i. "A" and "B" on west side
 - ii. "A" and railroad on west side
 - iii. railroad and North Shore and west side
 - iv. Village Shopping Center and Foothills Road on east side
 - g. continued pursuit of a way to accomplish a grade separation of the railroad at State Street
 - h. negotiations with Southern Pacific, to minimize railroad crossing during peak commuter hours (7-9 a.m.; 3:30-6:00 p.m.) and assure that switching of cars will be accomplished between 10 p.m. and 6 a.m.
 - i. a relocation of the access to Foothills Road, as far south of "A" as possible, to provide adequate left turn sanctuary for left turn from State onto "A" Avenue
7. Require adequate parking space to be provided to serve each business and public activity. Businesses will be required to provide such parking either on-site or in shared facilities.
- The City's role in provision of such facilities will be determined by the City Council, and may include such actions as the following:
- a. planning, designing, and approving location
 - b. administration of parking time limits on-street and in municipal facilities, in order to increase the availability of parking for shoppers
 - c. acquisition of land for such facilities
 - d. construction of some public facilities
 - e. arranging financing of such facilities by appropriate means, such as:
 - i. bonds payable out of revenue from said facilities
 - ii. business tax on all properties in the business district
 - iii. local improvement district with assessments on appropriate properties
 - iv. state or federal grants or aid
 - v. general property taxes
 - vi. parking fees or special charges derived from users or commercial enterprises benefited

8. Should Council determine that a Civic and Cultural Center will be located within the East End Community Business District, policies to guide its development will be made a part of this Plan. Policies will outline criteria to guide development of the center as an integral part of downtown revitalization. Criteria should cover:
 - a. location of components (e.g. City Hall, Police and Fire administrative offices, meeting rooms, City Court, exhibition space, Library, public parking, etc.)
 - b. size, location, and site design
 - c. traffic and pedestrian circulation
 - d. orientation to the Lake and to commercial activity

Public Facilities Element and Capital Improvements Program will outline components, acquisition and development priorities and schedule and methods of financing.
9. Provide design standards which encourage revitalization of the business district, including:
 - a. fire code standards which encourage commercial development in keeping with revitalization policies as well as safety
 - b. height and setback standards to facilitate pedestrian convenience and appropriate site design
 - c. business or floor area standards to encourage more intense use of land, within the limits of available parking. Floor Area Ratio may be increased and on-site parking decreased when provisions are made for customer parking in shared facilities.
 - d. procedures to allow for transfer of development rights between private owners (or other available means) to allow more intense use of certain lands in return for public view easements adjacent to the Lake or Lakewood Bay
 - e. standards which encourage:
 - i. combined landscaping projects to protect significant features
 - ii. substitution of significant trees for larger landscaped areas
 - iii. multi-story buildings where compatible
 - iv. mixed uses including handicrafts, housing and cottage businesses
 - v. signs which are adequate to inform potential customers and provide aesthetic appearance
 - vi. joint use and central parking facilities
 - f. implementation of these standards as a condition of zone change and/or Development Review approval.
10. Develop design standards which will improve the social interaction and aesthetics of the commercial district, including requirements for the provision of:
 - a. views of the lake, river, and Mt. Hood (could include open space, roof or other on-building public view points)
 - b. pedestrian orientation to distinctive features, particularly recognizing the aesthetic value of the Lake
 - c. street trees to provide shade and aesthetic relief from concrete and asphalt
 - d. pedestrian walkways (covered where possible) and bikepaths in alleys and walkway easements
 - e. street furniture and landscaped areas situated to encourage people to rest awhile for conversation (could include publicly owned pocket parks)
 - f. lineal parks (could be developed in alleys like court yards, with potted trees and furniture)
 - g. implementation of these standards as a condition of Development Review approval
11. Attach specific conditions to new commercial use approval, where appropriate, to assure that development is in accord with Specific Commercial District Policies. Such commercial use approval include:

- a. zone change
- b. conditional use and expansion of conditional use
- c. conversion of a residential structure to commercial use
- d. development review

IB. Riverfront Subarea

The Riverfront Subarea located south of Foothills Road and east of State Street along the Willamette River, as shown on the East End Commercial Business District Map, page 101, is well suited to a combination of high intensity uses, residential, commercial, office and retail, including river oriented public open space and major public facilities.

The subarea could accommodate a plaza or an esplanade adjacent to the river, providing views and a focal point. Such a facility, in combination with a variety of commercial/retail/office uses and a residential component, could create an attractive center that would benefit the entire East End Business District.

The residential use is intended to be at a high density (R-0) with mixed uses allowed either on the first floor or in separate buildings.

Physical constraints include access to and traffic capacity of State Street, the City's desire to retain views of Mt. Hood from the business and residential districts to the west, the railroad tracks running through the property, the Willamette River Greenway, steep slopes and the demolition required to clear the site.

The unique characteristics of the site include river access and Mt. Hood views, which should be developed in a manner that assures:

- 1. Public access to the river
- 2. Protection of Mt. Hood views from 'A' Avenue
- 3. Opportunities for views of Mt. Hood and the Willamette river from the site
- 4. Provision for a pathway allowing for a future connection to Tryon Creek and George Rogers parks
- 5. Public open spaces and major public use facilities

The City-owned Roehr Park and old sewage treatment plant are located within this subarea and may provide opportunities for land exchange to secure at least equivalent public river access within the subarea and to facilitate development. Residential development may be clustered to preserve open space while securing views for residents.

The on-site improvements will be planned as part of the Overall Development Plan and Schedule (ODPS) that must be approved for the entire 45+ acre site prior to the division of land, or the development of any structure. Any divisions of land related to the State Street Improvement project will be exempted from this provision.

GENERAL POLICIES

- I. The 45+ acre Riverfront Subarea is designated R-0/GC to allow for a mix of high density residential, commercial, retail and office uses.
- II. The opportunity for development of at least 500 dwelling units shall be included as the residential component of the Subarea.

Revised 10/86

- III. The Subarea shall be developed only pursuant to an Overall Development Plan and Schedule (ODPS) which will provide for:
 - A. Significant public access to the river,
 - B. Protection of Mt. Hood views from 'A' Avenue and the Bluff,
 - C. Protection of the views of Mt. Hood and Willamette River from the Subarea,
 - D. A future pathway allowing access to public pathways connecting the Subarea to Tryon Creek and George Rogers Parks,
 - E. Major public use facilities such as an esplanade, amphitheater, public square or plaza which provides for connection to and views of the waterfront,
 - F. The reasonable opportunity for development of 500 dwelling units through the allocation of sufficient land for residential purposes to accommodate the units.
- IV. Roehr Park/old sewage treatment plant acreage may provide opportunities for some land exchange to facilitate private development; however, any such change of ownership will assure at least equivalent public access to the river and public facilities. (PA 06-86-02-383, 10/17/86)

II. Grimm's Corner Neighborhood Commercial District

Grimm's Corner is a historic neighborhood commercial district located at the intersection of early market roads and a strategic center for the Palisades-South Town area which it serves with gas stations, a grocery, dry cleaners, appliance repair, etc. A variety of more intense uses have developed over the years, including lumber yard, bark dust storage, and bowling alley. Public facilities nearby include the National Guard Armory, Fire Station and tennis courts. Lakeridge High School to the south, generates traffic through this area also. This volume of activity has created traffic congestion and conflicts between uses, which increase as development of the area continues.

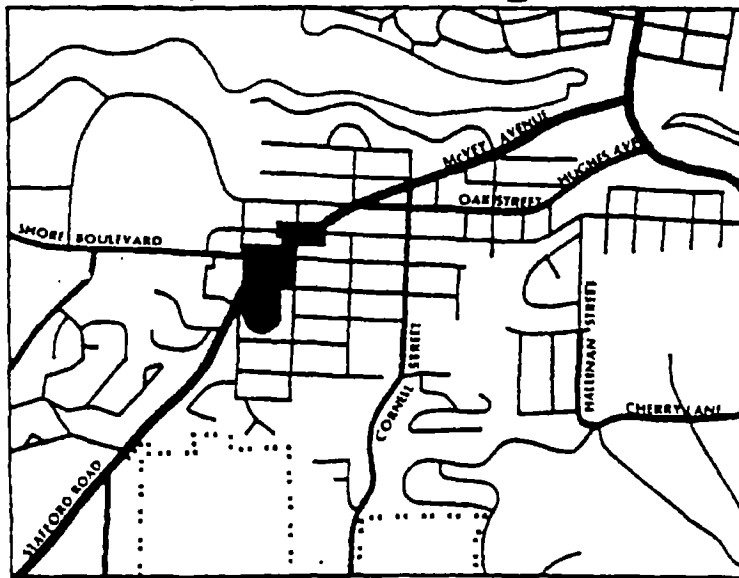

Grimm's Corners Neighborhood Commercial

In order to make possible development of commercial and residential property, while providing an intersection which can handle expected traffic, the following policies will direct further development of the commercial district.

Revised 10/86

1. Commercial land use will be extended south into the floor of the quarry, but not south to include properties fronting on Pine Street (approximate 0.7 acre expansion).
2. When the McVey/South Shore intersection is re-designed, the following criteria will be considered:
 - a. adequate travel lanes in each direction on McVey, plus left turn lanes where necessary
 - b. adequate through travel lanes on South Shore, with left and right turns where necessary
 - c. adequate site distance and safe access (in some cases this may require transfer of property or development rights between public right-of-way and private property)
 - d. signalization of intersection
 - e. public transit stop
 - f. pedestrian and vehicle safety
 - g. adequate access to McVey from commercial land. For land southeast of McVey and south of Parrish Street, direct access can be developed:

- i. at the vicinity of Parrish Street
 - ii. opposite South Shore, as part of a signalized intersection
 - iii. at least 200 feet south of South Shore intersection
- h. needs for bikeways, sidewalk, utility, landscaping and access and traffic signals will dictate the design of the street, right-of-way needs and ultimate pavement width
- 3. New commercial development will provide goods and services to serve principally residents of the neighborhood area.
- 4. Access to McVey Street will be limited, to assure safety of the intersection and convenience for through traffic.
 - a. Land uses and their expected auto trip generation will not exceed the capacity of the intersection as designed.
 - b. Patton access should be realigned.
- 5. Floor Area Ratio of new development will not exceed .25 for the site, except in the southeast quadrant, because of unique topographic problems. In that case, more intense use will be limited within the design capacity of the intersection.
- 6. Bikeway and pedestrian paths should be provided to assure safe passage through the intersection. These should include:
 - a. sidewalk on both sides of McVey, one side of South Shore
 - b. bike lane on southeast side of McVey and south side of South Shore
 - c. alternate bike route via Conifer, City-owned open space at Patton, and Oak Street, to bypass the intersection
- 7. All development or redevelopment will be required to conform to these policies and to pay a pro-rata share of street improvements, commensurate with need created by the development and the benefit gained, and to dedicate adequate right-of-way to make these improvements possible. (The public will assume some responsibility for a pro-rata share. See Definitions and Transportation Element.)
- 8. City-owned Douglas fir grove north of Laurel, adjacent to the Patton Street right-of-way, should be maintained as a natural area, with benches and a bikeway-pedestrian trail along the streamway, as a focal point for neighborhood commercial district.
- 9. Adjacent residential neighborhood will be protected from the negative effects of commercial activity. Methods include:
 - a. Pedestrian/Bikeway only should connect commercial area at Hemlock, for neighborhood convenience.
 - b. Redesign of the intersection should discourage through traffic into neighborhood.
 - c. Conditioning redevelopment of quarry area to eliminate the truck traffic and bark dust operation, in favor of more compatible uses
 - d. Encouraging both commercial and residential property owners to provide structural and landscape barriers to separate incompatible uses

III. Rosewood Neighborhood Commercial District

The Rosewood Neighborhood Commercial District serves an approximately 1.3 square mile residential area and a portion of the adjacent industrial area, with convenience goods and services. Commercial activity includes drugs, groceries, florist, fast food and office space. Within five blocks of a junior high and an elementary school, Rosewood Center serves many bike and pedestrian shoppers. The site is significant as the location of a distinctive grove of fir trees, valued by residents, as well as a meeting place at the center of a largely developed single-family neighborhood. The surrounding 1.3 square mile area can be expected to grow to approximately 6,000 people at full development.

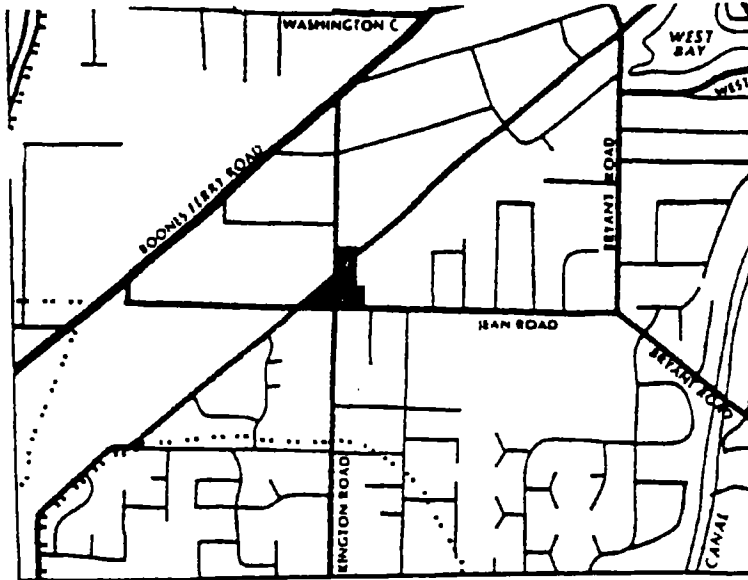

Rosewood Neighborhood Commercial District

Commercial development in this area should be designed to assure the following:

1. Uncongested streets with safe intersections and adequate parking.
2. Total commercial use in the area to be within the traffic carrying capacity of adjacent streets.
3. Shared access away from intersections, and redesign and straightening of some intersections.
4. Safe access by bike riders and pedestrians.
5. Protection of the Douglas fir grove and significant trees in parking lots.
6. A neighborhood commercial area, providing goods and services for residents of the immediate area, and scaled as a part of that neighborhood with a FAR not to exceed .25.
7. A minimum amount of impermeable surface, and adequate storm drainage management.

IV-A. West End Business District

Specific Commercial District Policies will guide development in the Lake Grove area to support businesses and new investment, to satisfy community needs, to encourage social interaction, to provide for proper vehicle access and to protect neighborhood living environment. The City will:

1. Limit the amount of new commercial land area in the Lake Grove area to an appropriate portion of Planning Area need. The City will plan for local needs, not for regional draw retail facilities.
2. Provide for pedestrian, bike, and auto traffic to connect new mixed use and commercial areas to the existing commercial district. This circulation should:
 - a. prevent isolation and/or deterioration of the existing commercial areas
 - b. encourage private development of a "village shopping center" in Lake Grove
3. Provide Specific Commercial District Policies for sub-areas of the West End Commercial District, to guide Zone Change, Development Review, and Building Permit approval.

4. Plan for a rear access and parking configuration on both sides of the current strip commercial development, to promote:
 - a. more intense use of deep lots fronting Boones Ferry
 - b. viability of the existing commercial center, so it can be redeveloped to remain competitive
 - c. modification of the negative effects of existing strip development
 - d. vehicle access constructed in a manner which protects adjacent neighborhood living environment
 - e. preservation of neighborhood residential property values
 - f. foot traffic within the commercial and neighborhood area

5. Encourage private development of:
 - a. joint-use parking facilities
 - b. land uses with size, floor area, and traffic generation compatible with the district's access and adjacent uses
 - c. buildings with height and setback standards compatible with the district
 - d. aesthetically pleasing entry into Lake Grove at Kruse Way and Boones Ferry Road
 - e. street trees to provide shade and aesthetic relief from concrete and asphalt
 - f. preservation of significant trees as a substitute for larger landscaped areas

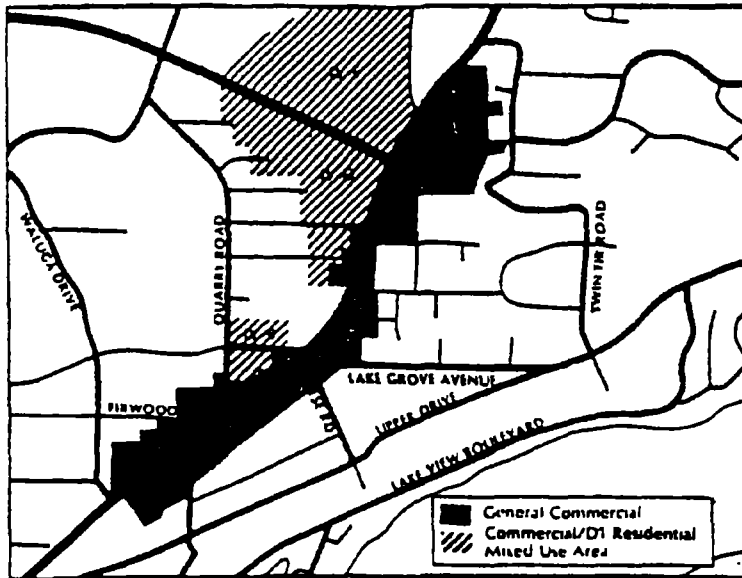

Westend Commercial District

- g. combined landscaping projects of significant size
- h. buffer system which separates adjacent residential uses from noise, traffic and congestion
- i. bike racks
- j. pedestrian walkways and bike paths in alleys and walkway easements
- k. alternate surfacing materials for parking areas which encourage on-site water retention, softened visual impact, noise absorption, etc.
- l. each property's share of connecting pathways to parks, recreation, shopping, work, parking
- m. street furniture and landscaped areas situated to encourage people to rest awhile for conversation in pleasant surroundings

6. Plan for adequate protection for residentially developed neighborhoods to enhance neighborhood living environment, and neighborhood stability. This protection will include:
 - a. specific land use designations and district boundaries, with allowed uses and densities specified, and adopted as part of the Comprehensive Plan. Structural boundaries will be planned and developed as conditions of development approval (i.e. street endings, structural buffers, tree planting, hedges, walkways, or other means to develop a permanent separation of incompatible uses)
 - b. buffering of residential properties from the noise, glare, and traffic congestion of the adjacent commercial area
 - c. encouraging residential property owners to provide trees and significant vegetation on their property, and other means to buffer their property from commercial areas

7. Provide incentives for private investment in compatible mixed uses, which will bring residents to the West End Business District during days and evenings for social or recreational purposes as well as to shop. Such incentives could include:
 - a. revision of zoning code to allow additional approved uses in commercial areas, such as residential care facilities, apartments, handicraft industry, recreation facilities
 - b. construction of safe bike and pedestrian routes.

8. Encourage development of adequate access and parking facilities.
 - a. On-street parking will be prohibited from collectors, arterials, and local streets which are not wide enough to safely afford parking, vehicle travel, and turning refuge. Adequacy of a street to handle on-street parking will be determined by the Planning Commission, with analysis by Public Works and Planning Departments.
 - b. All parking demand created by new structures or uses, additions to existing structures or uses, and change of use in existing structures shall be accommodated on the premises entirely off-street or in shared parking facilities.
 - c. Required parking spaces for each business may be reduced, if:
 - i. business shares a parking lot with a use which has peak use at a different time of day
 - ii. public parking is provided within walking distance adequate to meet the parking need thus created.
 - iii. business shares construction costs of bikeway serving the property.
 - d. Encourage provision of access and/or parking facilities which aid in decreasing the number of direct access points on arterials. The City's role in provision of such access or facilities will be determined by the City Council in accord with Oregon Law (including ORS 223.105; 223.805-880; 281.510) and may include the following:
 - i. grant permission for private construction and provision of such facilities
 - ii. plan, design, and locate parking facilities
 - iii. construct, alter or maintain such facilities
 - iv. contract with any person, firm, or corporation for such services
 - v. acquisition of such facilities by lease, purchase, condemnation, exchange or other lawful manner
 - vi. make possible financing of such facilities:
 - by bonds payable out of revenue from said facilities
 - by local improvement district with assessments on appropriate properties
 - by state or federal grants or aid
 - by general property taxes
 - by parking fees or special charges from users or commercial enterprise benefited

9. Protect the function and service level of Boones Ferry Road as an arterial street.
- Use of off-street parking spots for businesses located on the arterial shall not require backing into the public way.
 - There shall be no more than one point of access to the arterial per 155 feet of street frontage. If necessary to meet this requirement, users shall arrange for shared access. (Existing uses will be encouraged to meet this standard.)
 - Businesses providing for rear access to another street may be granted the right to more intense lot coverage, waiver of height restriction, variance from appropriate setbacks, or decrease in landscaping requirement, if compatible with adjacent properties and necessary to the public welfare.
10. Protect the function and service level of Kruse Way as an arterial:
- All access to Kruse Way will be planned to serve the adjacent properties while minimizing the frequency and severity of traffic conflicts.
 - Aesthetic natural entry into Lake Grove from Kruse Way will be preserved.
 - Access points already designated by Clackamas County may be the basis for the street planning which may provide shared access at these points. Land owners will be required to plan for frontage roads or unified site and street plans which implement the City's Transportation Plan.
 - Should comprehensive traffic analysis and site planning indicate a need to alter Kruse Way ingress or egress patterns, the City will plan such access, and the City Council will seek County implementation of adopted plan.
 - Property owners will pay for street improvements, traffic controls, and public facilities necessary to their development (including intersections).

IV-B. Oakridge Mixed Use Sub Area

The Oakridge area is a planned commercial and residential area served by Quarry, Oakridge, and Boones Ferry. It is an expansion of the existing commercial district, and as such should be developed in a manner which assures:

- revitalization of the adjacent businesses on Boones Ferry by improving traffic circulation, parking access, and pedestrian circulation
- proper vehicle access and street design
- pedestrian paths and bikeways which connect Waluga Park, Lake Grove School, and the commercial district to the residential areas to the west
- shared parking and street access where possible, to relieve traffic congestion
- protection of adjacent residential areas from the noise and bright lights of commercial activity
- proper vehicle, pedestrian and bike access to the Post Office at Oakridge and Boones Ferry
- equitable sharing of the costs of necessary streets and public facilities
- preservation of major trees in the area.

The commercial area bounded by Bryant, Boones Ferry, Reese, and the pedestrian easement north of Sunset will share a rear access connecting parking lots to Bryant and Reese Roads, to provide relief of traffic congestion on Boones Ferry.

IV-C. Bryant to Reese, North of Sunset

Commercial properties in this area will be developed in a manner which assures:

- access of each property to an internal access route from Bryant to Reese Roads. This route should not be developed as a straight through high speed road but should meander through connected parking areas.

- b. access to Bryant at a point opposite the Lake Grove Shopping Center, between 300–330 feet south of Boones Ferry
- c. access to Reese at a point opposite Lake Grove Street
- d. more intense use of deep lots between the six-foot pedestrian easement and lots fronting Boones Ferry Road
- e. careful building location, structural buffers, trees and shrubs to minimize the negative impacts on adjacent residential area
- f. separation of commercial and residential uses along the line of the pedestrian easement
- g. protection of Sunset from through traffic
- h. convenient pedestrian and bikeway access from residential areas at Bryant and Reese
- i. a decrease in the number of direct access points to Boones Ferry
- j. effective site development, with appropriate variances granted to assure the access, parking, circulation and site features outlined in these policies
- k. preservation of the major trees, by such means as setbacks, clustering of structures, protection of root systems

IV–D. Southwest Quadrant of Kruse Way/Boones Ferry Intersection

The Southwest Quadrant at Kruse Way/Boones Ferry is an area planned for residential and commercial uses to meet a variety of community needs in an area with good access to arterials, mass transportation and diverse public facilities, including wooded open space, school, park, post office and the Lake Grove Swim Park. The commercial uses are intended to serve local, as opposed to regional shoppers. This area is an expansion of the existing Lake Grove Commercial District, and as such should be developed in a manner which assures:

1. Designation of approximately 20 acres of commercial use south of Kruse Way and north of Collins Way, and approximately three acres of commercial land use between Lake Grove School and Collins Way. Residential development is appropriate within the commercial area, particularly in the westerly portion of Tax Lots 1300 and 2200 of Tax Map 2 1E 8BC Supplemental and Tax Lots 2000 – 2200 of Tax Map 2 1E 8BB. Any building over 20,000 sq. ft. shall occur north and east of Mercantile Drive.
2. Preservation of the capacity of Kruse Way and Boones Ferry to carry projected through traffic and to provide adequate access for all planned land uses in the vicinity of the intersection.
3. Proper location of access points and an internal circulation system which provides for vehicular, pedestrian and bicycle movement.
 - a. The City will determine the location of access points and prepare a circulation plan to meet the needs of all development within the quadrant, prior to zone changes.
 - b. The City will vacate the necessary street segments to provide for internal circulation and site plans.
 - c. The preferred internal circulation route design should be integrated with parking areas rather than as a separate street.
4. Limited access to Kruse Way and Boones Ferry.
5. Principal access to residential development from Galewood.
6. Connection by pedestrian and bicycle paths with the residential areas, and to the rest of the Lake Grove Commercial District, with safe passage across Kruse Way to the office campus development to the north.
7. Appropriate dedication of necessary rights-of-way to provide for traffic projected for Boones Ferry, Kruse Way, Douglas, Gresham, Galewood and Quarry.
8. Payment of a pro-rated share of costs of streets, traffic control improvements (i.e., intersections and signals) and necessary rights-of-way, parking, bikeways and pedestrian ways, by property developments creating the need for those facilities.

9. Preservation of the quality of life in the single-family residential area to the west, particularly by the landscaping and placement of buildings and parking areas.
10. Building area or Floor Area Ratios may be designated as necessary to limit vehicle trip generations within the capacity of adjacent streets.
11. Preservation of major trees, sufficient to preserve woodland character.
12. Site planning for each development which assures that the development's access circulation, parking, landscaping, building design, and drainage are properly related to adjacent developments.
13. Consideration of general design objectives

The overall objective is to create a village-like shopping and service center, with a variety of local goods and services provided in an attractive setting. The basic elements will include:

- a. the size and scale of buildings, which should be in keeping with other development in Lake Grove, particularly in height and bulk. No single building may have greater than 20,000 sq. ft. floor area on one level except in the shopping center area bounded by Kruse Way, Boones Ferry Road, Mercantile Drive and the stream corridor.
- b. relationship of buildings, which should be clustered to create usable open areas such as plazas, courtyards and entryways.
- c. scale of parking areas, which should be designed to avoid larger, unbroken areas of paving through smaller lot areas; landscaped areas, and lot configurations.
- d. provision of pedestrian environment that encourages walking between stores, office and other uses by providing safety, easy visual orientation, and by careful location of attractions to walking shoppers.
- e. separation of loading and service areas from pedestrian areas
- f. as feasible, use of visually identifying elements such as building shapes, displays (sculpture, colors, kiosks, flagpoles, outdoor furniture, signs) landscaping, parking and other details.

IV-E. Office Campus - Northwest Quadrant of Kruse Way and Boones Ferry

The northwest quadrant of the Kruse Way and Boones Ferry intersections has been designated for Office Campus land use. This 53-acre land area bounded by Carman, Davis Lane, Kruse Way and the westerly edge of properties fronting Carman on the west, may be approved for a mix of regional offices and residential use if standards are established to assure:

- a. 35% to 60% office use
35% to 60% residential use
a maximum of three acres of commercial to serve adjacent offices and residences
- b. a land use intensity compatible with adjacent residential neighborhoods
- c. preservation of the capacity of Carman, Boones Ferry and Kruse Way to carry through traffic
- d. limited access to Kruse Way, Carman Drive and Boones Ferry
- e. connection by pedestrian and bicycle paths with residential areas and with safe passage across Kruse Way to the commercial area to the south
- f. access to residential property east of Davis Lane to Davis and/or Carman Drive
- g. appropriate dedication of necessary right-of-way to provide for traffic projected for Boones Ferry, Kruse Way, Carman Drive and Davis Lane
- h. payment of a pro-rated share of costs of streets, traffic control improvements (i.e. intersections) and necessary rights-of-way, parking, bikeways and pedestrian ways, by property developments creating the need for those facilities
- i. preservation of major trees, with an effort to maintain wooded character.
- j. FAR not to exceed .38 for 8 acre site bounded by Kruse Way, Kruse Way Place and Boones Ferry Road. Maximum FAR to be reduced, based on resulting traffic impacts, if any retail uses placed on 8 acre site. 8/20/85

IV-F. Office/Residential Mixed Use Area – East Side of Boones Ferry at Kruse Way

The area on the east side of Boones Ferry Road between the existing commercial district zone boundary and Spring Lane is designated as a mixed use Office Campus and R-3 density residential area.

Low intensity Deleted 12/28/82

This designation permits Office Campus uses or residential structures in portions of this district which lie between Springbrook Creek and Boones Ferry Road. Land in this district which lies east of the Creek is to be used solely for residential uses in accord with the residential policies and Land Use Map of the Comprehensive Plan. 12/28/82

Development in this district will be required to:

- a. utilize a rear access route on Red Cedar Way, Division Street, Boones Way and Spring Lane with no driveway access allowed on Boones Ferry Road
- b. dedicate the necessary right-of-way to connect Division Street to Boones Way and dedicate needed right-of-way on Boones Ferry Road.
- c. develop each parcel with mixed use potential under unified site plans to assure adequate access, circulation, parking and screening
- d. protect the Springbrook Creek stream corridor and its deep ravine from development encroachment
- e. take access only onto the rear access route described in a., above and not onto Twin Fir Road
- f. preserve major trees, with an effort to maintain wooded character
- g. allow mixed uses within buildings on the west side of Springbrook Creek
- h. dedication or acquisition of right-of-way east of Boones Ferry and Kruse Way intersection will be arranged prior to development. Land is necessary for a future additional left turn lane from Kruse Way north into Boones Ferry.

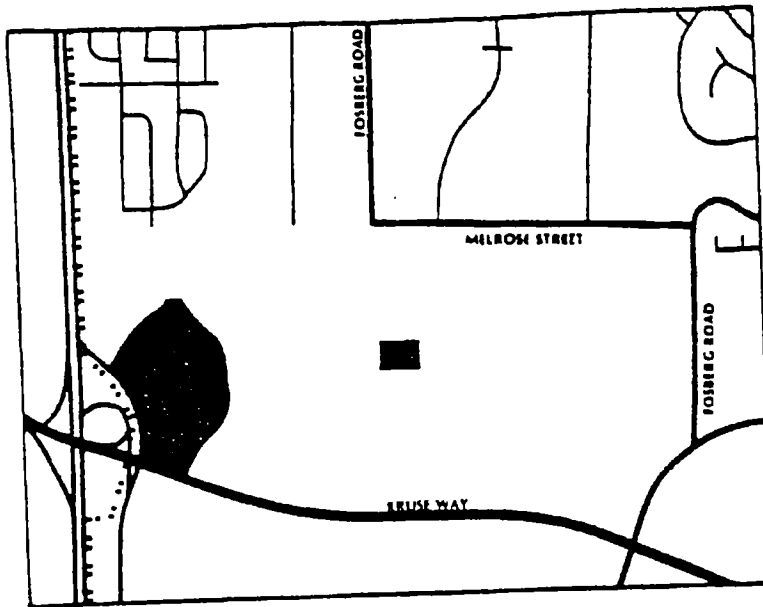

I-5/NE Kruse Commercial District

V-A. Highway Commercial District I-5 and Kruse Way Northeast Quadrant

The northeast quadrant of the I-5 and Kruse Way intersection has been designated for highway oriented commercial land uses. This area is separated by slope and major trees from residential lands to the east, thereby protecting residential areas from the traffic congestion of such a commercial district.

The site of this Commercial District includes two streamway ravines and associated wet areas, one on the north edge and one across the lower third of the site. For this reason, the 35-acre site has been designated for 20 gross acres of commercial activity, which will allow landscaping, protection of streamways and major trees to occur in the remaining 15 acres.

Commercial activity at this location should be designed in a manner which assures:

- a. a highway oriented commercial district, with minimal disruption of adjacent residential areas
- b. a limit on the intensity of commercial activity on this site, to an amount which preserves the capacity of Kruse Way and the I-5 intersection for other public and private uses outlined in the Lake Oswego Comprehensive Plan
- c. one access point to Kruse Way, preferably east of a point 1500 feet from the Bangy Road intersection
- d. payment of costs of streets, street improvements, intersections, necessary rights-of-way, parking, bikeways and pedestrian ways by property development creating the need for those facilities
- e. Planning and Development Review procedures which assure:
 - i. adequate vehicle access and street design
 - ii. protection of adjacent residential areas from the noise, bright lights and air pollution of commercial activity
 - iii. protection of the stream corridors, as major functioning parts of basin wide storm drainage system and as aesthetic features at the entry way into the Lake Oswego area

V-B. Highway Commercial District Bangy Road and I-5

Highway oriented commercial activities and gas stations have located over the years along Interstate-5, with access via Bangy Road to Kruse Way and I-5. As the lands to the north and east of Bangy Road develop, an increasing number of vehicles will use the Bangy Road/Kruse Way intersection, including industrial traffic from Tigard and Lake Oswego industrial areas, north and southbound to I-5.

These specific policies apply to the area south of Kruse Way, west of Bangy and south of Kruse Way and east of Bangy for approximately 1700 feet. The area includes the 'Liberty Park' project approved by Clackamas County and additional area south of that project. (12/18/85-PA 4.5,6-85)

Commercial development in this area should be planned to assure:

- a. minimum congestion on Bangy Road which must serve through traffic
- b. minimum number of vehicle accesses from commercial development
- c. no on-street parking on Bangy Road, Kruse Way, Meadows Road or Bonita Road (12/18/85-PA-4.5,6-85)
- d. adequate off-street parking for commercial uses
- e. adequate varying setbacks, landscaping and signage and major tree preservation to provide safe sight distance and attractive boulevard like setting (12/18/85-PA-4.5,6-85)
- f. appropriate dedication of right-of-way along Bangy and Bonita Roads, to accommodate road widening necessary for full development of the area.
- g. Require parking areas to be screened from view from Kruse Way.
- h. Encourage employers to provide employee incentives for the use of public transit such as:
 - providing bus shelters and turnouts
 - mass transit fare reimbursement programs
 - providing preferred reserved spaces for car pool parking
 - posting transit route and scheduling information
- i. Traffic generation will be limited so as not to exceed the planned capacity of the surrounding public street system.
- j. Encourage major employers on the site to schedule shifts so as to reduce peak hour traffic congestion when feasible.

(12/18/85 - PA 4.5,6-85)

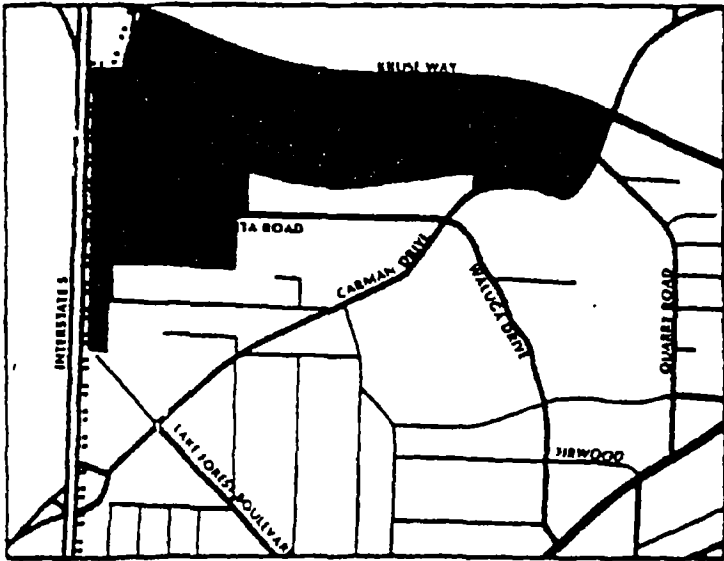

I-5/Bangy Commercial District

V-C. Kruse Way Campus Research and Development District.

These specific district policies will assure the Kruse Way Campus Research and Development District develops in a manner consistent with the City's General Commercial Land Use Policies as well as other Comprehensive Plan elements. The policies are categorized under General Site Development and Design, and Traffic and Circulation.

General Site Development & Design Policies.

- a. Development intensity will be limited to that allowed under the Bunke Kruse Way Corridor Transportation Program (1983).
- b. Development of the district will occur through the use of a unified general site plan. The unified general site plan will be required and will include:
 1. A general internal circulation plan for the overall site.
 2. A general plan for adequate drainage and all utilities needed to serve the site.
 3. Consideration of the site development and design policies in the Comprehensive Plan.
 4. Development intensities.

The unified general site plan could be approved as part of a zone change, subdivision or planned development for the site. If desired, property owners or developers could submit a unified general site plan for approval apart from these three specific types of applications.
- c. Benefitted property owners will be required to pay costs for installation of all public utilities, with City financial participation in oversizing.
- d. Major allowed uses in the Kruse Way Campus Research and Development District will include:
 1. light manufacturing, assembly uses
 2. research, experimental and testing laboratories
 3. general office
 4. retail commercial (PA 6-88-615, 11-16-88)
 5. recreation facilities
- e. Require landscaping and preservation of existing vegetation to assure a park-like setting will be maintained.

Traffic and Circulation Policies

- f. Limit the number of access points to the minimum necessary, consistent with efficient traffic circulation, and assure access points are coordinated with the City's Major Streets Plan and Transportation Policies.
- g. Require a complete and efficient internal circulation system with adequate access to all development portions of the site.

- h. Require parking areas to be screened from view from Kruse Way.
- i. Provide adequate parking, loading and maneuvering space for employees, visitors, and trucks.
- j. Encourage employers to provide employee incentives for the use of public transit such as:
 - providing bus shelters and turnouts
 - mass transit fare reimbursement programs
 - providing preferred reserved spaces for carpool parking
 - posting transit route and scheduling information
- k. Streets should be designed to accommodate large trucks.
- l. Traffic generation will be limited so as not to exceed the planned capacity of the surrounding public street system.
- m. Encourage major employers on the site to schedule shifts so as to reduce peak hour traffic congestion when feasible.

VI Kruse – North Neighborhood Commercial District

A residential area is planned for the 230-acre area north of Kruse Way, bounded by Melrose Street and properties fronting Fosberg Road and Carman Drive. A neighborhood commercial center of three acres or less is planned to serve this residential area, located centrally within the residential area, not on Kruse Way.

This neighborhood commercial center should be designed to assure:

- location of not more than 35,000 square feet of retail commercial activity, to serve the shopping needs of the adjacent residential areas
- shared access points on collector streets and a unified site plan for the three acre site, to assure internal circulation and to prevent traffic congestion on residential streets
- development standards which encourage private development in accord with:
 - height and setback compatible with the district and adjacent residential areas
 - structural and vegetation buffers to separate adjacent residential areas from noise, traffic and congestion
 - pedestrian walkways, bikeways and safe bike storage, providing a convenient safe alternative to auto travel
 - street furniture and landscaped areas situated to encourage social interaction
 - shared parking facilities and walkways to encourage pedestrian circulation throughout the site. Parking lots should be designed with adequate trees and landscaping, in accord with Air Quality and Quiet Environment Elements of this Plan.
 - public transit service.

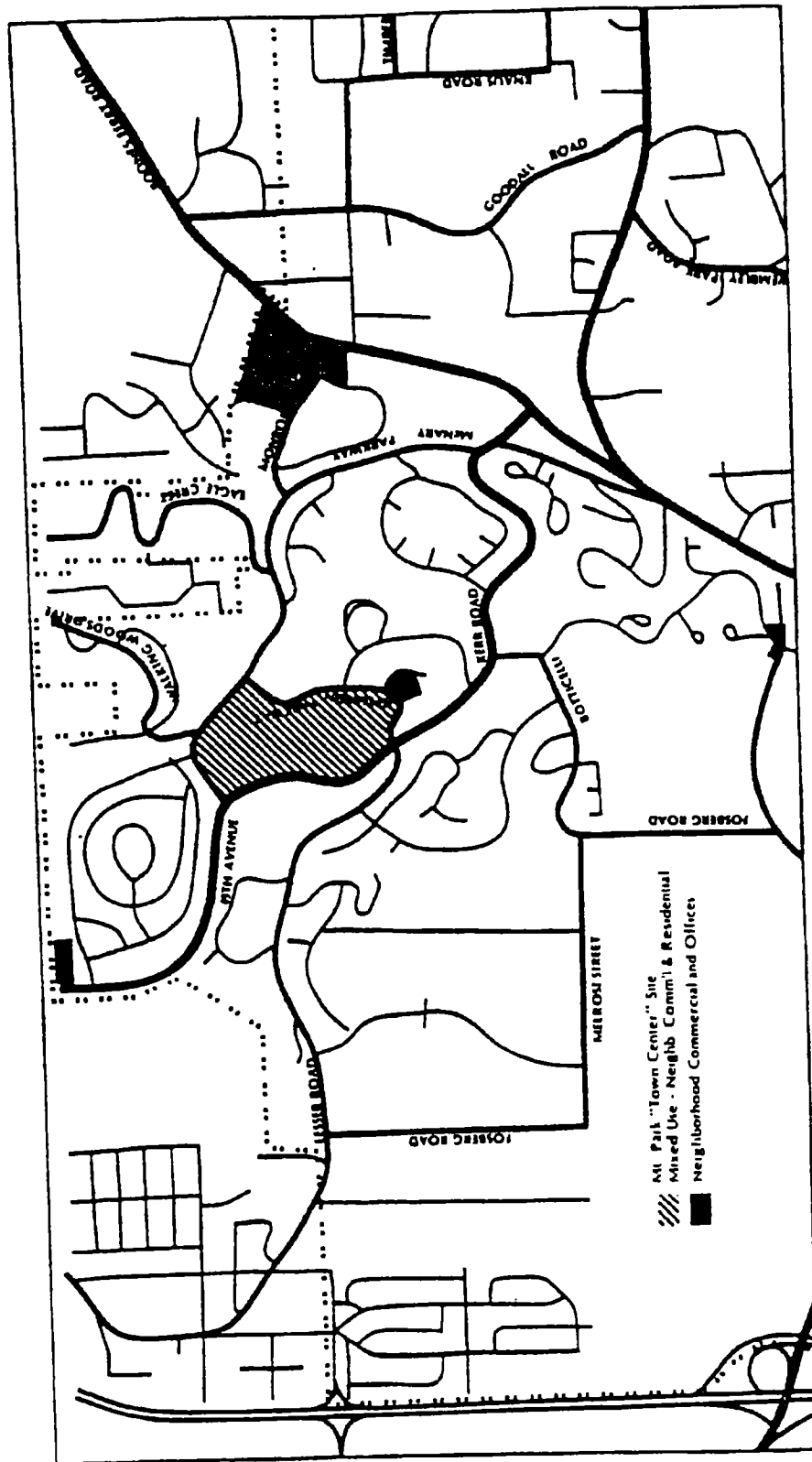

Mt. Park Commercial District

VII. Mountain Park Commercial Areas

The areas designated as "General Commercial" in the development ordinance for Mountain Park Planned Unit Development (Ordinance No. 1411) are redesignated as Neighborhood Commercial, to ensure that retail commercial uses principally serve the residents of Mountain Park. The City will assure that, in accordance with the policies in VII-A, VII-B and VII-C, below specifically defined maximum building area limits for commercial land uses are established.

Neighborhood Commercial in Mountain Park may provide for a range of retail, personal services, restaurant and cultural uses. Offices may provide for professional business services, financial, institutional and other uses.

VII-A. Town Center Site (PA 1-89-713; 10-04-89)

1. The 32-acre Town Center site is designated for a mix of high-density (D), residential and retail commercial uses. The following maximum intensities will apply:
 - a. Up to 492 residential dwelling units.
 - b. Up to a total of 40,000 sq. ft. of retail space.
2. Pedestrian access to the site should be provided for to encourage walking from adjacent residential areas.
3. Development will pay a pro-rated share of the costs of improving Kerr Parkway and providing traffic signalization which shall be required because of Town Center generated traffic.

VII-B. Monroe/Boones Ferry Site (PA 3-92; 10-08-92)

1. The 13 acre site is designated for retail and office commercial uses. The overall building area on the site shall not exceed 131,535 sq. ft.
The site development plan approved as part of the PUD should be revised to permit commercial uses which would be appropriate for present needs for types of commercial uses.
2. Pedestrian access should be provided.
3. Development will pay a pro-rated share of the cost of improvements to Boones Ferry Road, and providing traffic signalization which may be required because of traffic generated from the site.
4. On-site drainage retention may be required, as feasible, to protect Springbrook Creek.

VII-C. Other Mt. Park Commercial Sites

1. The following sites are designated neighborhood commercial:
 - i. Two parcels on Touchstone (\pm 1 acre each)
 - ii. Parcel on Kerr Road across from Portland Community College (\pm 2.5 acres)
 - iii. Parcel on Jefferson Parkway at its intersection with the proposed Kingsgate Street (\pm 1 acre)
 - iv. Parcel on Jefferson Parkway adjacent to Mt. Park Recreation Center (\pm 2 acres)

(Rev. 07-02-93; ba)

APPENDIX 50.12
CAMPUS INSTITUTIONAL ZONE

MARYLHURST CAMPUS INSTITUTIONAL AREA

Campus Institutional: Definition

Land uses allowed in Campus Institutional areas are all Office Campus uses, including those for educational, religious, social services, governmental agencies, related residential uses and facilities for care of the handicapped or other special care needs, located in a campus setting which preserves a substantial amount of landscaping and open space and the character of existing institutions.

GENERAL POLICIES

1. A mix of uses within the Marylhurst campus will be allowed, including educational, cultural, social, governmental and residential activities.
2. The campus-like character of the area will be maintained as much as possible.

APPENDIX 50.12 - A

3. Traffic and access will be controlled to preserve the capacity of Pacific Highway and the intersections at Marylhurst. Proper internal circulation will be provided.
4. The Willamette River Greenway will be preserved for scenic and recreational uses.

SPECIFIC POLICIES

FOR GENERAL POLICY 1: Provide for a Mix of Uses

1. Designate the Marylhurst Campus for a variety of land uses and establish the specific uses, conditions and design criteria for sub-areas within the campus, to assure proper development.
2. Require each sub-area to have a plan for circulation, parking, utilities, and general building placement as a condition of approval for all development other than single-family subdivisions.
3. Establish permissible uses, intensities, development criteria and conditions for specific sub-areas within the campus, in addition to other policies.
 - a. SUB-AREA I: CAMPUS INSTITUTIONAL
 1. Allowed uses will include educational, religious, social service, governmental, institutional housing, and their supporting services.
 2. The appearance and character of the present Marylhurst Education Center campus, especially the scale of buildings, parking areas, building locations, materials, open areas and landscaping, will be continued in new development.
 - b. SUB-AREA I-A: CAMPUS INSTITUTIONAL
 1. Uses should be located in a major building and no more than two buildings.
 2. Design of access to the eastern portion of the site must provide for emergency vehicles.
 3. Development may not occur beyond the top of the banks of the drainage ways. Removal of trees will be minimized as much as possible.
 4. Access into the site must be designed to be compatible with the existing Education Building, and should be located on the north side.
 5. Vehicle access or parking in the eastern portion of the site will be discouraged.
 6. Drainage management must be designed to prevent erosion of the banks of the drainage ways which have a severe potential landslide hazard.
 - c. SUB-AREA II: CAMPUS INSTITUTIONAL
 1. Commercial uses allowed (including Office Campus) must be buffered from Pacific Highway.
 2. Structures will be located to maintain open areas which preserve a campus-like setting. The view of St. Anne's Chapel from the southern access drive will be preserved.
 3. Site design will orient buildings towards views and preserve highway and access road views as much as possible.

APPENDIX 50.12 - A

d. SUB-AREA III: CAMPUS INSTITUTIONAL

e. SUB-AREA III-A: RESIDENTIAL (R-10)

1. Access to Old River Road must be designed to provide a safe intersection, and to minimize disturbance to the wooded slope along the road. If these conditions cannot be met, the area must be provided access from the campus.
2. Residential development will be required to provide street trees. Development must be visually screened from the school and convent.
3. Emergency vehicle access from the campus side must be provided.
4. Changes to topography will be the minimum necessary to develop the property.

f. SUB-AREA IV: CAMPUS INSTITUTIONAL

1. Allowed uses will be Campus Institutional, including social service institutions and residential care facilities for the physically or mentally handicapped. Agricultural uses may be continued as long as they are compatible with new development.
2. A pedestrian access to Pacific Highway may be located at the north end of the site.

g. SUB-AREAS V AND V-A: RESIDENTIAL (R-10 and R-15, respectively)

1. Allowed uses will be residential (R-10 and R-15), with clustering encouraged.
2. Site design should assure that views to the east are preserved and utilized.
3. A unified site plan for each sub-area, required prior to development, shall include provisions for buffering the adjacent residential areas.
4. Interior streets rights-of-way will be dedicated. Street trees will be required.

FOR GENERAL POLICY II: Maintain Campus-Like Character

The City will:

1. Assist Marylhurst in preparing architectural and site design criteria to be utilized as supplements to the Development Review standards for all future development at Marylhurst. The criteria will assure that development is harmonious with the existing campus buildings and landscaping. Criteria at minimum will assure:
 - a. maintenance of the architectural character of the existing buildings and landscaping.
 - b. scale, height, bulk, lot placement and building materials in new development which will maintain the open character and be properly related to the existing structures.
 - c. preservation of scenic vistas to the east
 - d. new landscaping will complement existing, especially types and placement of trees
2. Ensure that the natural drainage courses are designated as open space. No development will be permitted, except for utilities, drainage management improvements or low-intensity recreational improvements, such as trails.

APPENDIX 50.12 - A

3. Ensure maintenance of a setback along Pacific Highway, which will include a minimum of fifty feet from the right-of-way line, to provide for the planting of trees. The City will assist with providing and planting of the trees, subject to the budgetary process.
4. Require buffers between non-residential campus uses and adjacent residential neighborhoods, including protection of views.
5. Require minimum changes in topography. Grading will be limited to that required for foundations, drainage management, parking areas and berms.
6. Assure that parking areas are scaled proportionately to the campus buildings and are landscaped to avoid the appearance of large, unbroken paved area.
7. Strongly encourage residential site design which is clustered and preserves open areas.
8. Assure that commercial uses are of a type and size to serve the residents and users of the campus, without drawing a larger market, and are located away from Pacific Highway to avoid any strip development.
9. Assure that utility construction will be coordinated with development and will prevent or minimize disruption of the existing buildings, streets, and drainage ways.

FOR GENERAL POLICY III: Preserve Highway Capacity and Internal Circulation

The City will (subject to the approval of the Oregon Department of Transportation, whenever applicable):

1. Limit access from the campus to Pacific Highway to the two existing access points.
2. Limit land uses to the degree necessary to ensure that total vehicle trips generated by campus land uses maintain the capacity of Pacific Highway and intersections.
 - a. Prior to new development, a traffic study will be prepared which will determine the projected volumes on Pacific Highway, the capacity available to future development at Marylhurst and improvements necessary to maintain the highway or intersections within Service Level "D".
3. Require that Marylhurst pay an equitable share of the cost of improvements to Pacific Highway for additional capacity and signalization required for additional development.
4. Actively seek transit improvements and increases in the levels of transit use in the Highway 43 corridor, to reduce vehicle trips entering the State Street Corridor.
5. Ensure that internal streets on the east side of Pacific Highway will remain private streets, except for the Residential area (sub-area III-A).
6. Require that internal access and circulation plans for each sub-area of the campus will be prepared and approved as part of the Development Review for the first new development proposed for the sub-area.
7. Require dedication of an additional ten feet of right-of-way on each side of Pacific Highway to widen the total to eighty feet.
8. Ensure that a minimum setback will be maintained along Pacific Highway at fifty feet from the right-of-way line to preserve the scenic corridor.

APPENDIX 50.12 - A

9. Allow no vehicular access from Old River Road, except to sub-area III-A.
10. Assure safe pedestrian and bicycle circulation within the campus and each sub-area.
 - a. Whenever possible, walkways will be separated from vehicular ways.

FOR GENERAL POLICY IV: Preserve Willamette River Greenway as a Recreational and Scenic Resource

The City will:

1. Assure that the area designated as Willamette River Greenway along Old River Road (generally from the river to the top of the steep bank above River Road) is maintained in a natural aesthetic condition.
 - a. Structures will not be permitted in the Greenway, except for recreational purposes or utilities.
 - b. Recreational Improvements will be in scale with the environment. Parking areas, if any, will be minimal.
 - c. Trees in the Greenway will be preserved.
 - d. No boat ramps will be permitted.
2. Designate the area between River Road and the river as Public Open Space, and the banks above the road and the drainage ways as Protection Open Space.
 - a. The City will attempt to negotiate an agreement with Marylhurst which will provide for public access and recreational use of the land between River Road and the river. The agreement may be for purchase outright, easement use or other method mutually agreeable to Marylhurst and the City.
3. Ensure that storm water runoff from campus development will be controlled to avoid erosion, sedimentation or damage to the drainage ways.

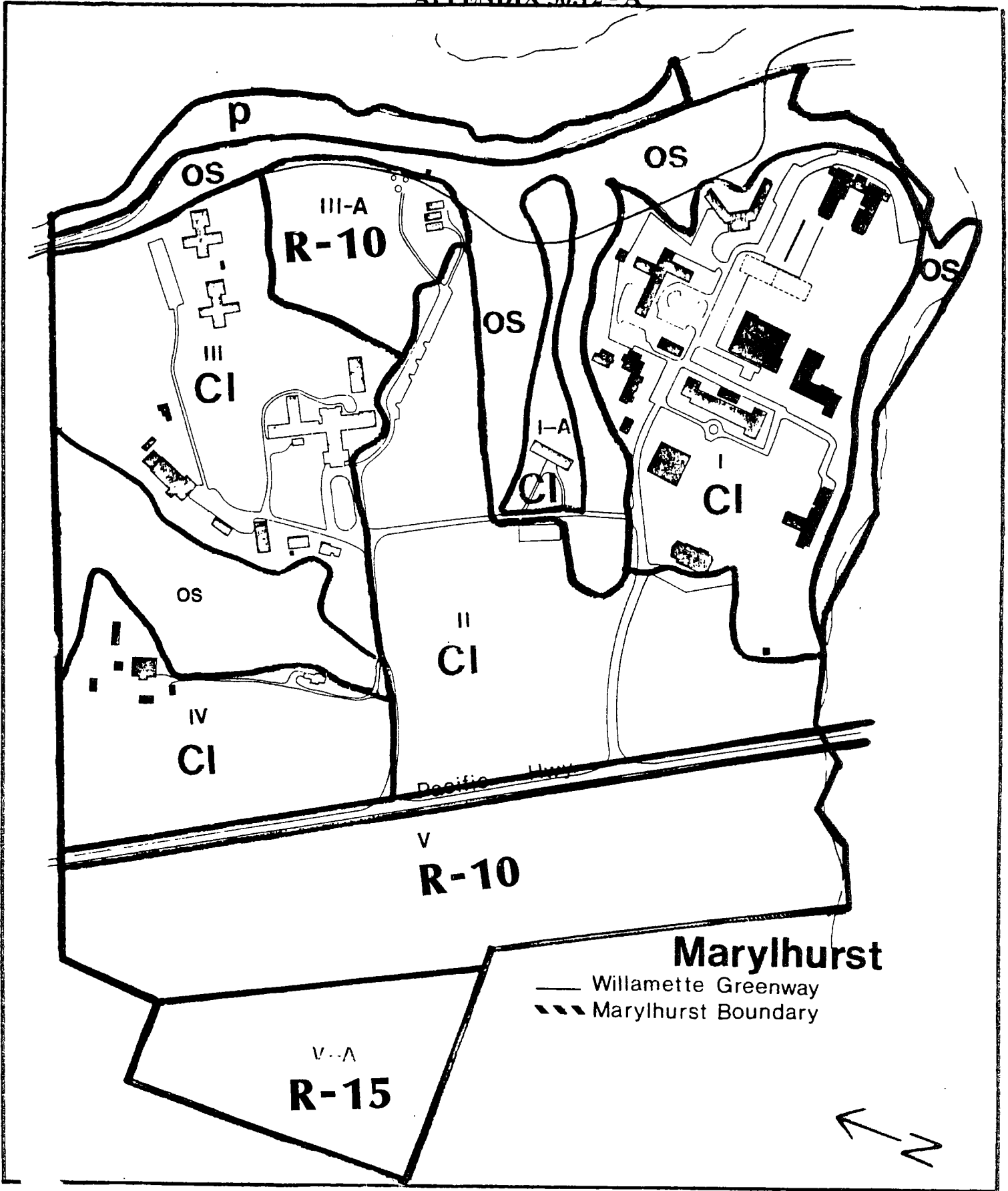

APPENDIX 50.13
INDUSTRIAL ZONES

Appendix 50.13 - A

INDUSTRIAL LAND USE POLICY ELEMENT

Background Information

Industrial land uses have existed in Lake Oswego all through its history. They originally developed on the Willamette River where proximity to water transportation attracted heavy industry such as Iron smelting and now cement production. Light industrial land use developed relatively late in Lake Oswego's history. In the early 1960's, a light industrial park zone was established by the City on Boones Ferry Road, adjacent to I-5. Despite this expansion of industrial zoning, industrial development remains a relatively insignificant part of Lake Oswego's overall character. Since 1950, the City's residential growth has outpaced any other type of development, and Lake Oswego has become a suburban residential community with few local employment opportunities.

In examining its future through comprehensive planning, the City found major adverse fiscal effects would occur if future growth were solely residential. The high per unit cost of public services for low density residential development and the failure of such development to supply adequate revenues are the causes of this situation. This finding led citizen task forces, Planning Commission, and City Council to conclude that additional industrial development would be desirable. Analysis also showed that public policies are needed to improve existing industrial developments in order to maintain and enhance their value.

Summary of Major Issues

Issues related to industrial land use which were resolved through the comprehensive planning process include:

- Could Lake Oswego's future growth include additional industrial development in order to counteract adverse fiscal effects of residential growth?
- Could additional employment opportunities be provided in the Lake Oswego area to help reduce commuting distances for future residents?
- Could additional area be designated for industrial development without degrading environmental quality in the community?
- Could the City take actions to encourage improvements in existing industrial areas?

Summary of Major Conclusions

The industrial land use policies are a product of extensive analysis by city staff, recommendations of a citizen task force, and review and modification by the City Council. The emphasis on increasing the amount of industrial development represents a major shift in previous development policies for Lake Oswego.

Conclusions reached in this process include:

- Additional industrial development is needed to help balance the fiscal effects of the community's growth.
- Light industrial park development can have a positive aesthetic and economic impact on the community while also not overburdening the transportation system.
- Suitable locations for a planned industrial park development exist in the Kruse Way Corridor.
- Specific city actions are needed in the existing Lake Grove Industrial Park to stimulate improvement, upgrading, and code compliance.

Summary of Supporting Documents

The following list includes supporting documents related directly to the development of the industrial land use policies. For a complete bibliography, refer to supporting documentation.

- Lake Oswego Community Goals, 1974
- Industrial Task Force Report, 1976
- Fiscal Impacts of Urban Development in Lake Oswego, (preliminary findings), 1976
- Minutes from Public Meetings of Industrial Task Force, 1976
- Lake Oswego Population Study, 1976

OBJECTIVE: TO ENCOURAGE INDUSTRIAL DEVELOPMENT COMPATIBLE WITH THE COMMUNITY IN ORDER TO INCREASE LOCAL EMPLOYMENT OPPORTUNITIES AND MAINTAIN A HEALTHY LOCAL ECONOMY.

GENERAL POLICIES:

- I. The City will encourage environmentally compatible industrial development located in visually attractive structures in landscaped settings.
- II. The City will encourage industrial development by assuring that adequate streets, utilities and public services exist to serve existing and proposed industrial areas.
- III. The City will encourage industrial development by establishing a clear, concise and unified development standards in order to minimize time for processing development applications.
- IV. The City will encourage industrial development by designating industrial park areas in appropriate locations in the Comprehensive Plan.

Specific Policies

FOR GENERAL POLICY I: Encourage environmentally compatible industrial development.

The City will:

1. Establish specific district policies for each industrial district to accommodate the unique conditions existing in each and use these specific district policies as conditions for actual development approval. These areas are:
 - a. Lake Grove Industrial Park
 - b. Willamette River Industrial Park

(Specific Policy c deleted 12/18/85)
2. Assure compliance with local, state and federal standard for noise, water quality, air quality, fire hazards, material storage and screening.
3. Initiate a program of code enforcement for all existing industrial areas to improve the areas' aesthetic quality and protect individual investments in buildings and landscaping.
4. Establish methods assuring the continued care and maintenance of buildings and grounds in the City's industrial areas.
5. Establish ordinances enabling the City to monitor and control impacts from changes or expansions in use in industrial districts.
6. Require all manufacturing operations in industrial parks to be conducted within an enclosed building.
7. Work with property owners in the Willamette River Industrial Area, in the event any major plant closures occur during the next 20 years, to plan in advance for a transition in land use that is:
 - a. Economically feasible for the industrial property owners, and
 - b. Compatible with the City's long range plans for the East End Business District
8. Plan adequate storm water runoff management systems and facilities in industrial districts and require developments to conform to City storm drainage policies.
9. Require exterior lighting in industrial districts to be designed so as not to shine beyond property lines adjacent to residential zones.
10. Require all outdoor storage in industrial parks to be screened from public view.

11. Require preservation of major tree stands wherever feasible.

FOR GENERAL POLICY II: Encourage industrial development by assuring adequate streets, utilities and public services.

The City will:

1. Place high priority on water system improvements which will assure adequate water volumes and pressure for the City's existing and proposed industrial areas.
2. Develop and implement a detailed Lake Grove Industrial Park improvement program in conjunction with property owners.
3. Assure timely completion of the Boones Ferry widening project and integrate this improvement with the local circulation system in Lake Grove Industrial Park.

(Specific Policy 4 deleted 12/18/85 – PA 4-85)

FOR GENERAL POLICY III: Encourage industrial development by establishing clear development standards to minimize time for processing development applications.

The City will:

1. Refine design guidelines for industrial park areas to clarify requirements for development review approval. (See Strategies for General Policy I).
2. Assist industrial park development proposals in obtaining DEQ indirect source permits.
3. Work cooperatively with individual industrial park development proposals to assist in complying with city and state regulations.
4. Review and revise all regulations affecting industrial development in the city and assure they are clear, concise and equitably enforced.

FOR GENERAL POLICY IV: Encourage industrial development by designating new industrial park areas in appropriate locations in the Comprehensive Plan.

The City will:

1. Expand the existing Lake Grove Industrial Park in a manner compatible with neighboring residential areas. (Recommended expansion is shown on map below.)

2. Require the new Kruse Way Industrial Park to be developed consistent with unified overall plan. Proposals for individual parcel development will not be considered prior to city approval of an overall plan for the total site.

This overall plan will include, but not be limited to stream protection, internal circulation plan, and preservation of major open spaces.

(Specific Policy 2 deleted and 3 renumbered 12/18/85 – PA 4-85)

Specific Policies

Specific Industrial District Policies.

FOR GENERAL POLICY V: Encourage environmentally compatible industrial development.

The following three sets of specific district policies will guide development in the existing and proposed industrial districts in the Lake Oswego Urban Service Area. Each district has unique conditions, thus individual polices are needed for each.

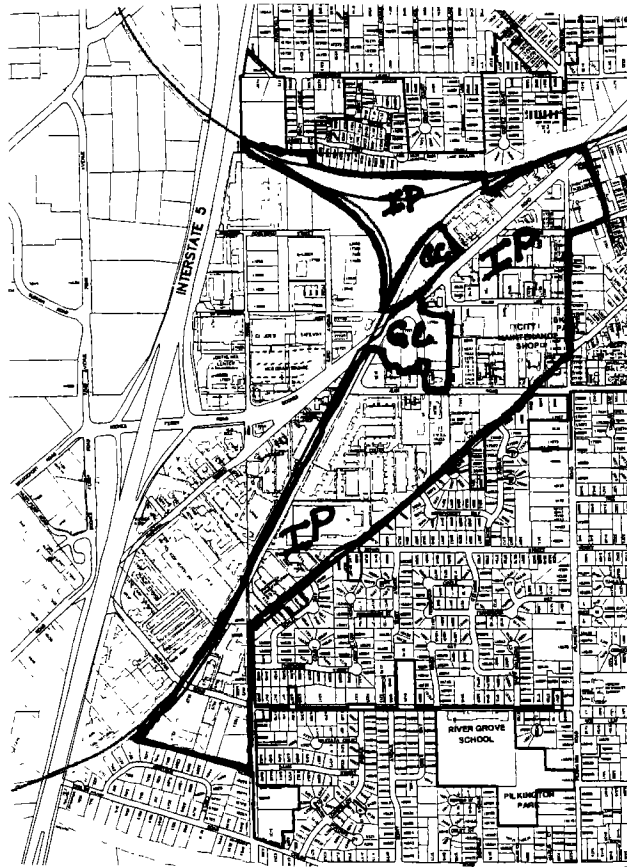

LAKE GROVE INDUSTRIAL PARK DISTRICT

1. Lake Grove Industrial Park District Policies.
 - a. Realign the Jean Road/Boones Ferry Road intersection as part of the Boones Ferry Road widening project to assure adequate truck turning radius.
 - b. Initiate measures to solve circulation and drainage problems, enhance the area's general appearance, and identify the southwestern entrance to the City.
 - c. Preserve major stands of trees where feasible.
 - d. Encourage developments on small parcels to develop shared access with adjacent parcels wherever feasible.
 - e. Assure adjacent residential areas are protected from adverse effects of industrial activities and land use.
 - f. Revise the existing "IP Zone" statutes in the Lake Oswego Code to require:
 - Compliance with the currently adopted noise performance standards and regulations of the Oregon Department of Environmental Quality.
 - Levels of maintenance of buildings and grounds.



WILLAMETTE RIVER INDUSTRIAL DISTRICT

2. Willamette River Industrial District Policies.
 - a. Investigate feasibility of moving the Foothills Road/State Street intersection further south to reduce traffic conflicts with the existing railroad crossing.
 - b. Require all proposed changes in use or expansions in use to provide the City with information on existing and projected truck and auto traffic levels.
 - c. Work with property owners to determine feasibility of a proposed trail along the Willamette River from Tryon Creek to George Rogers Park.
 - d. Encourage general improvement of the area's visual quality. (See Willamette River Greenway, Natural Resource policies).
 - e. Investigate possibility of new or alternative access points to the Willamette River Industrial District.
 - f. Coordinate future planning for the East End Business District with the development in Willamette River Industrial Area.
3. Kruse Way Industrial Park District Policies.
(Kruse Way Industrial Park District Policies and map deleted
12/18/85 – PA-4, 5, 6-85)

M:\Appendix-50.13-A.rtf

APPENDIX 50.16
SENSITIVE LANDS OVERLAY DISTRICTS

Appendix 50.16 - A

Lake Oswego Resource Areas Report and ESEE Analysis dated April 1, 1997, as revised on July 15, 1997.

On file with the Lake Oswego Community Planning Department

M:\Appendix-50.16-A.rtf

Appendix 50.16 - B

DELINEATING STREAM CORRIDORS

Methods for Establishing Stream Corridor Boundaries.

The stream corridor shall be delineated in the field by a qualified professional and surveyed by a registered professional surveyor. Stream corridor boundary maps shall then be prepared by a registered professional land surveyor or engineer, and verified as accurate by the Planning Director.

In order to establish the exact location and width of an inventoried stream corridor, one of the following methods described below shall be applied, depending on the nature of the terrain adjacent to the stream.

1. Flatland Stream Corridor. The stream corridor boundary shall be either, 10 feet as measured from each side of the centerline of the stream, or the edges of the stream channel, whichever is greater. Refer to Figures A₁ and A₂.
2. Streams with associated Wetlands. The stream corridor boundary shall include delineated wetlands of which any part is within or abutting the stream corridor. Refer to Figure B.
3. Streams with associated Ravines or Steep Slopes. The stream corridor boundary shall include associated ravines and steep slopes up to the "natural slope break" at the top of the ravine or steep slope. The "natural slope break" is at the intersection of the plane of the flat land at the top of the ravine and the plane of the steep slopes of the ravine. Refer to Figure C.
4. Streams with Topographic Variations. Topographic variations are areas where the topographic contour of the site has been altered to the due to natural processes or by human activity. These may include slides, slumps, local depressions, cuts, or fills. When such an alteration has obscured the definable stream corridor boundary, the stream corridor boundary shall then be defined by connecting clearly definable stream corridor boundary points from upstream and downstream of the altered area utilizing the methodology in No. 3 above. Refer to Figures D₁ and D₂.

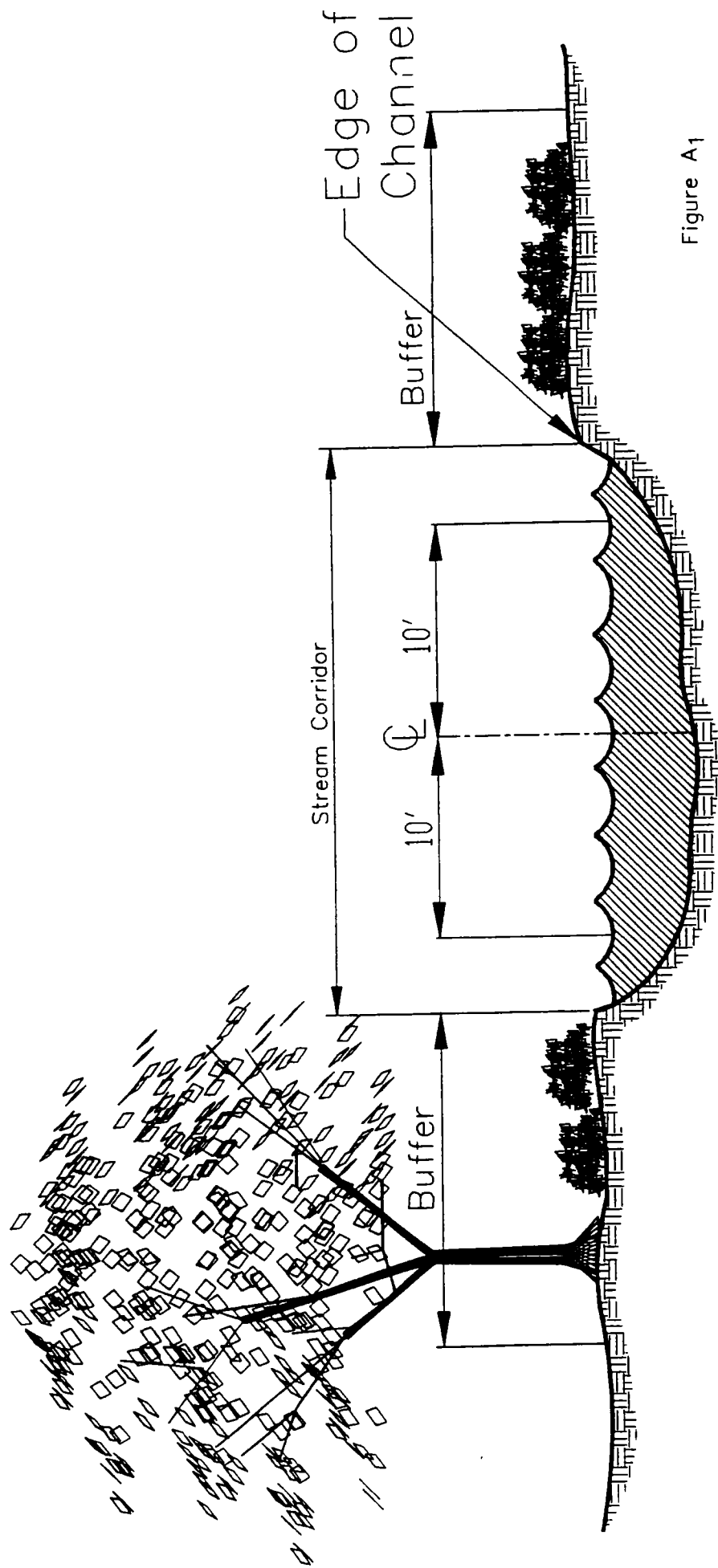
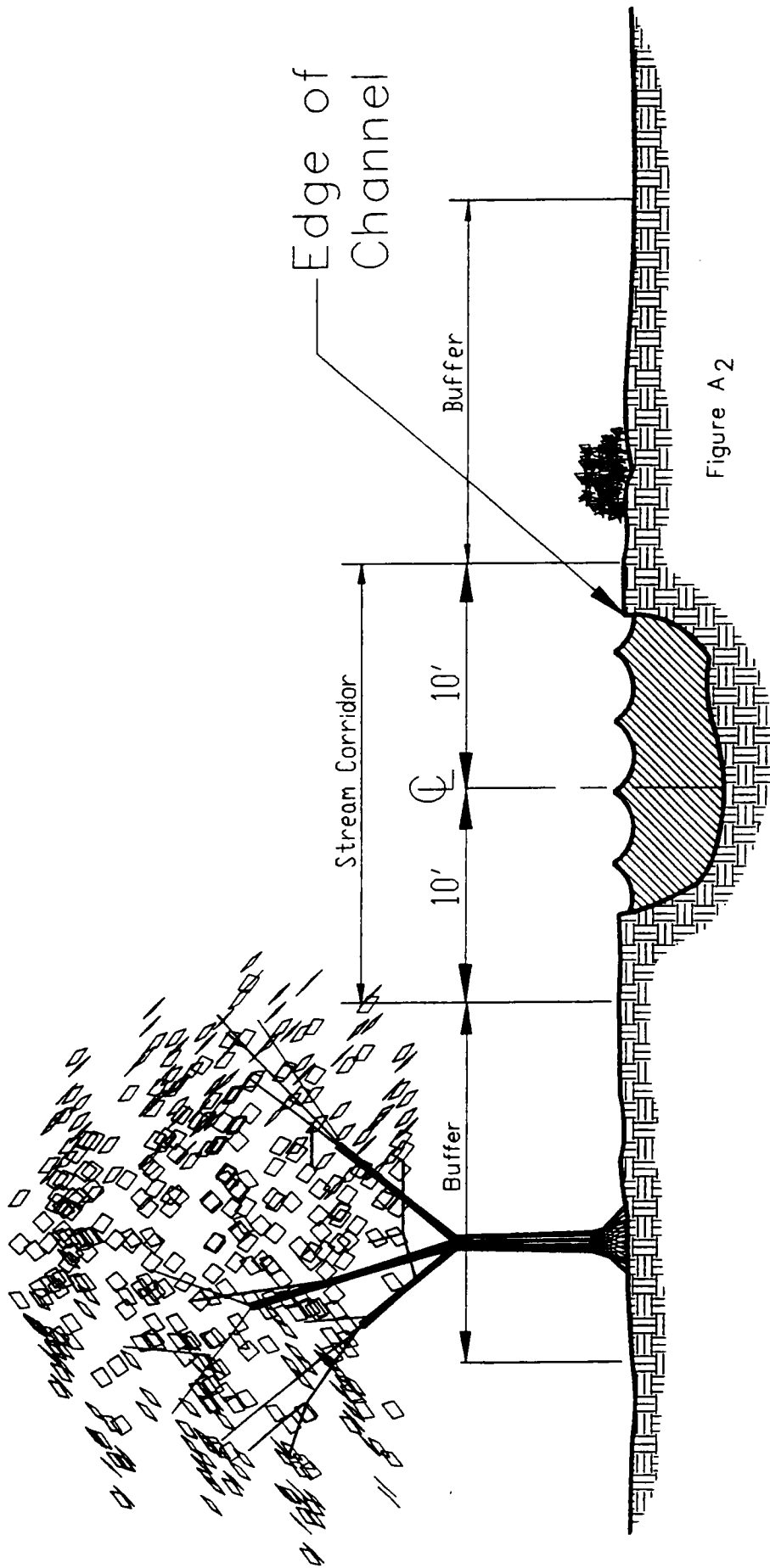

Figure A1

FLATLAND STREAMS

(NO WETLANDS, FLOOD PLAINS, OR STEEP SLOPES)



FLATLAND STREAMS

(NO WETLANDS, FLOOD PLAINS, OR STEEP SLOPES)

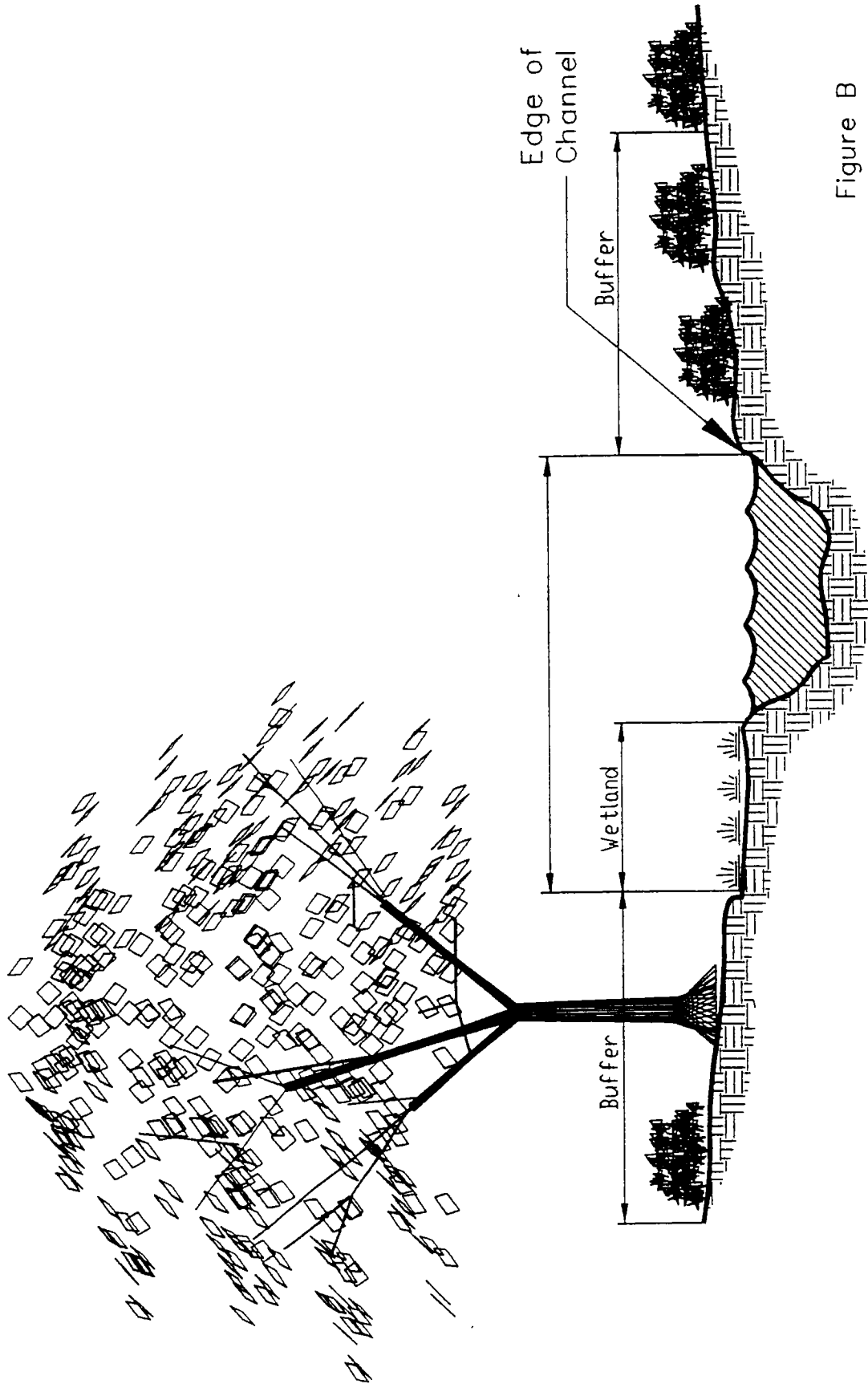

STREAMS WITH ASSOCIATED WETLANDS

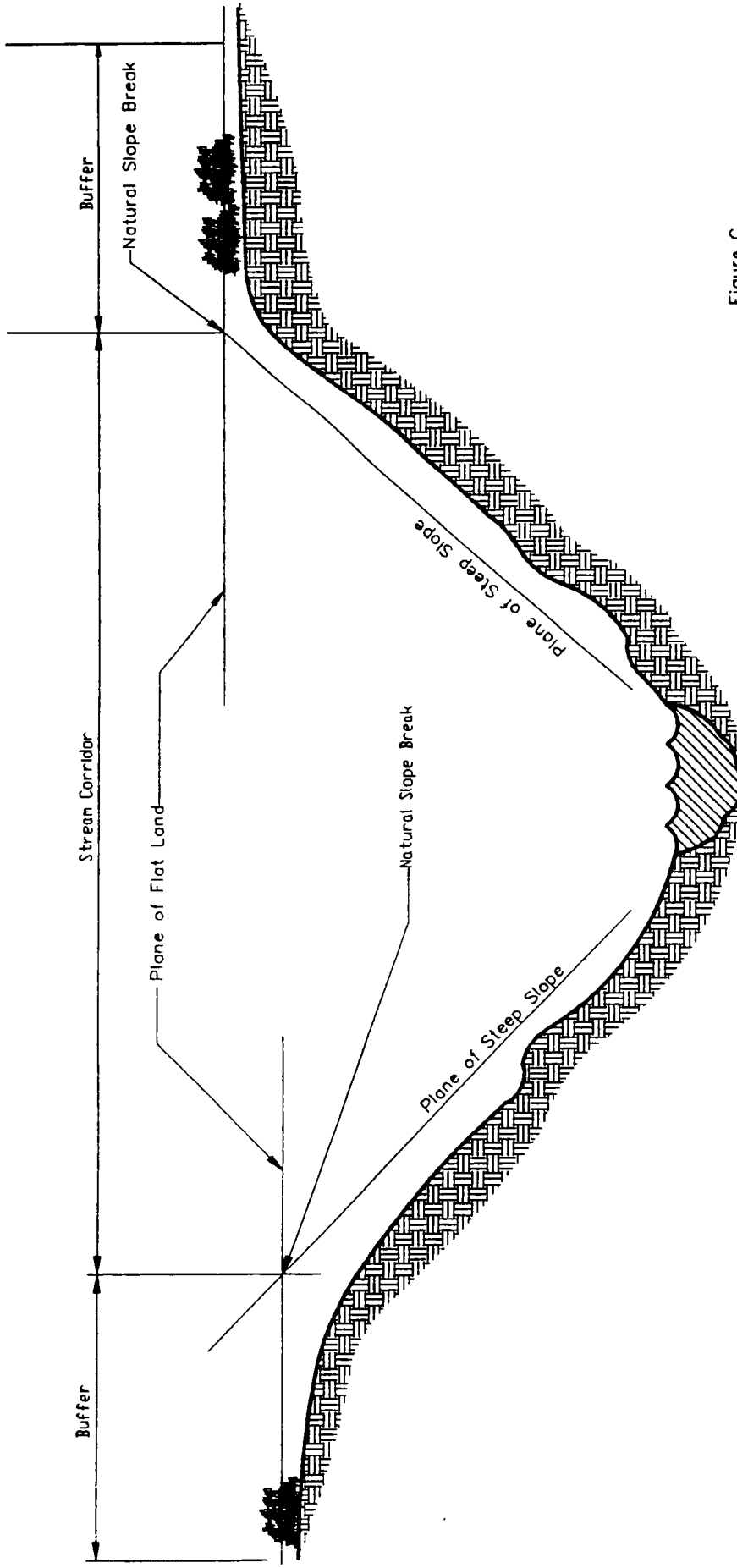

Figure C

STREAMS WITH RAVINES OR STEEP SLOPES

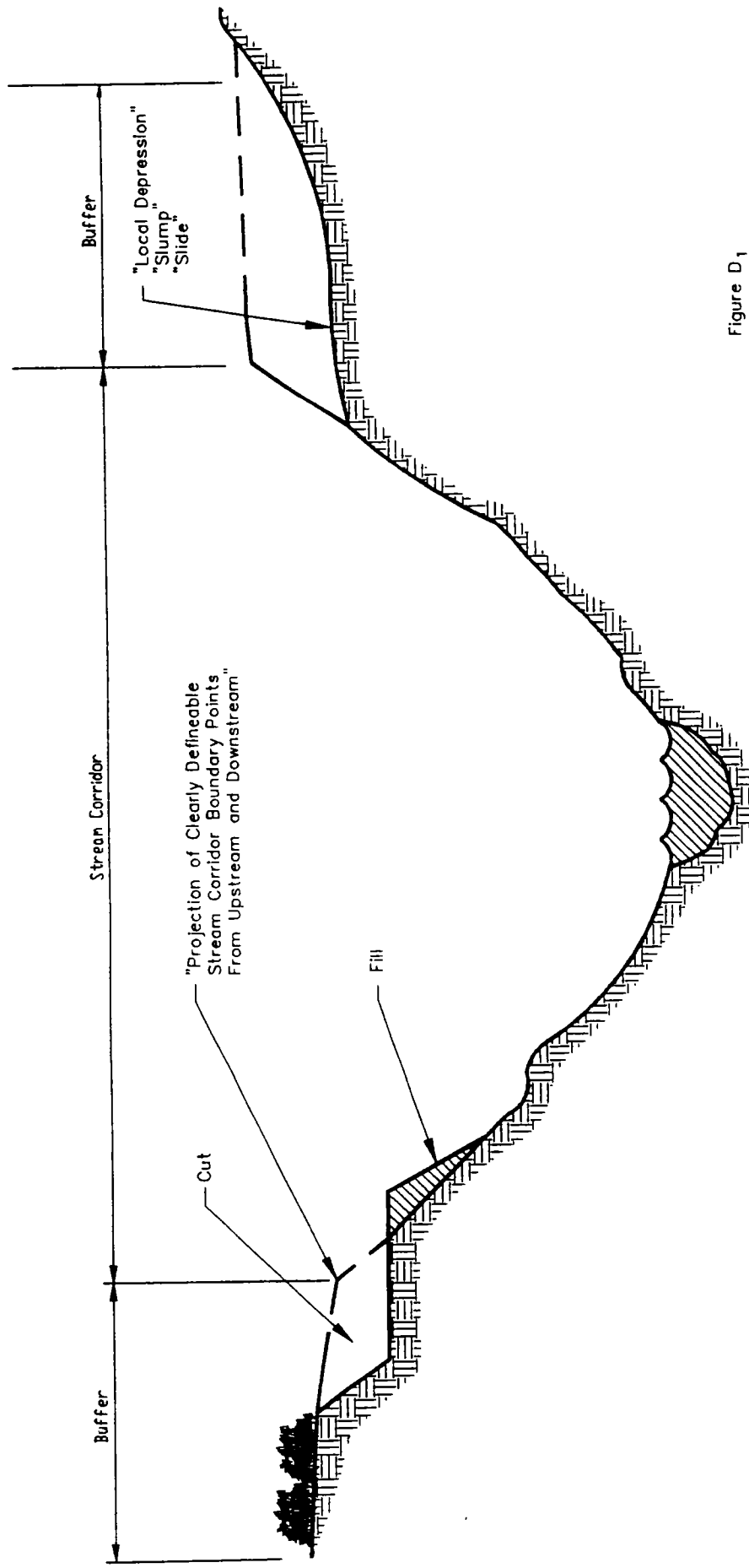

Figure D₁

STREAMS WITH TOPOGRAPHIC VARIATIONS

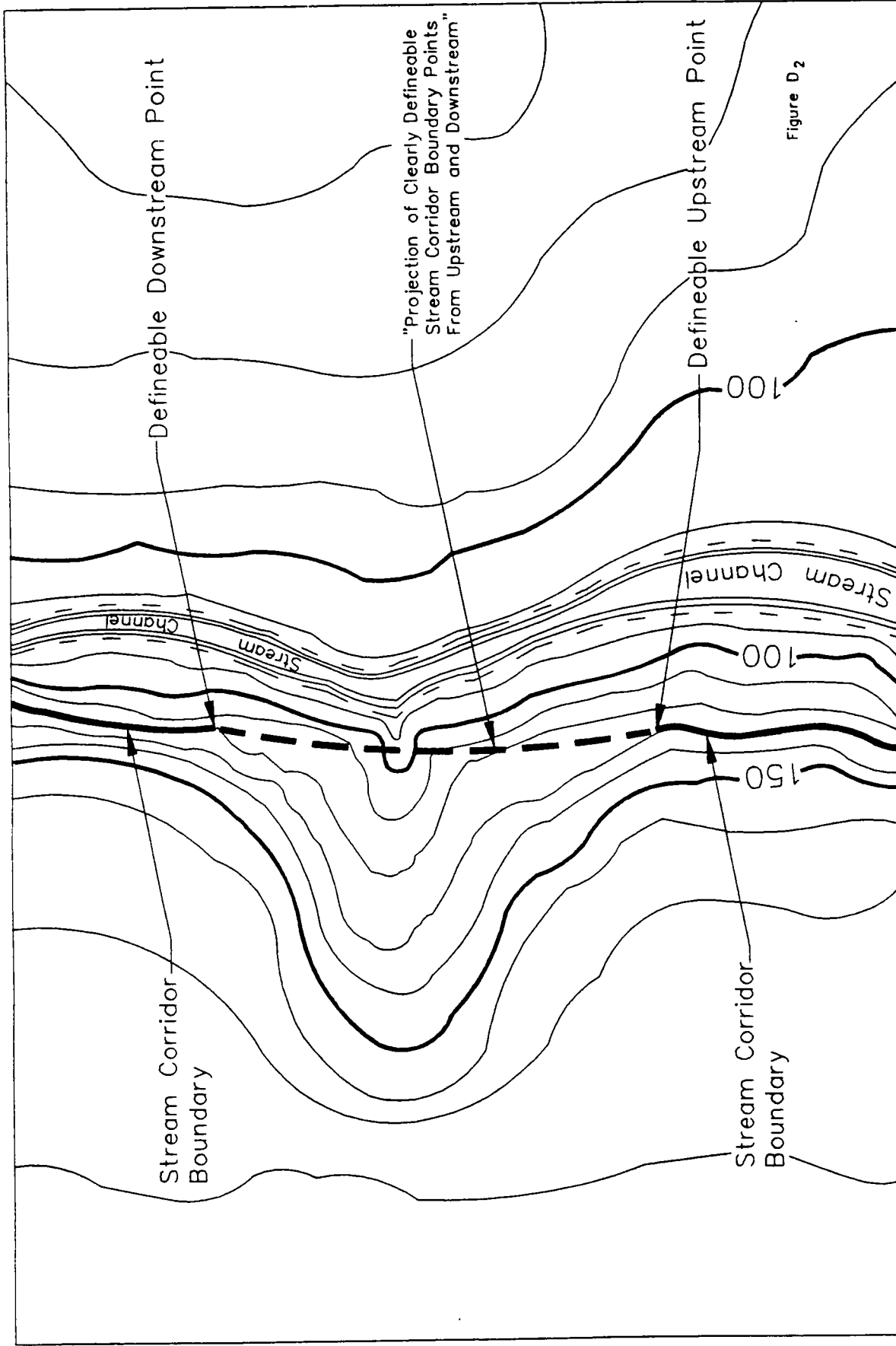

Figure D₂

STREAMS WITH TOPOGRAPHIC VARIATIONS

Appendix 50.16 - B
Figure D₂

APPENDIX 50.21
VISION CLEARANCE

Appendix 50.21 - A

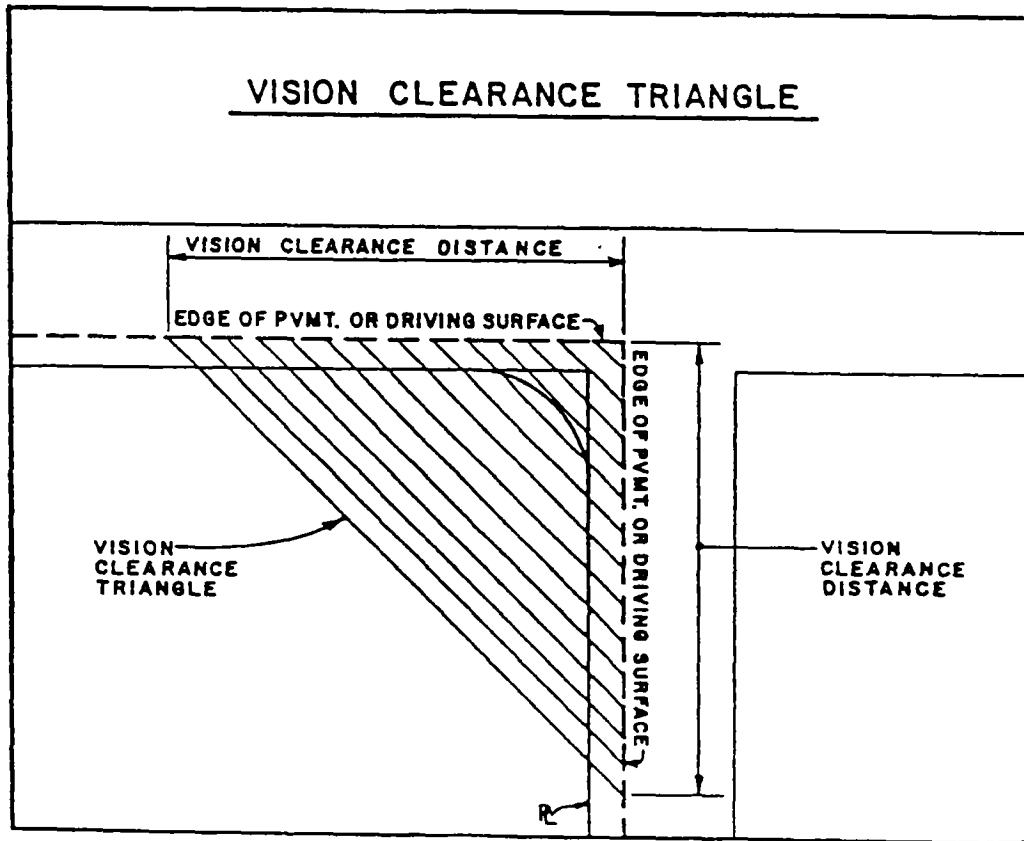

APPENDIX 50.22
EXCEPTIONS TO SITE DEVELOPMENT STANDARDS
AND SPECIAL DETERMINATIONS

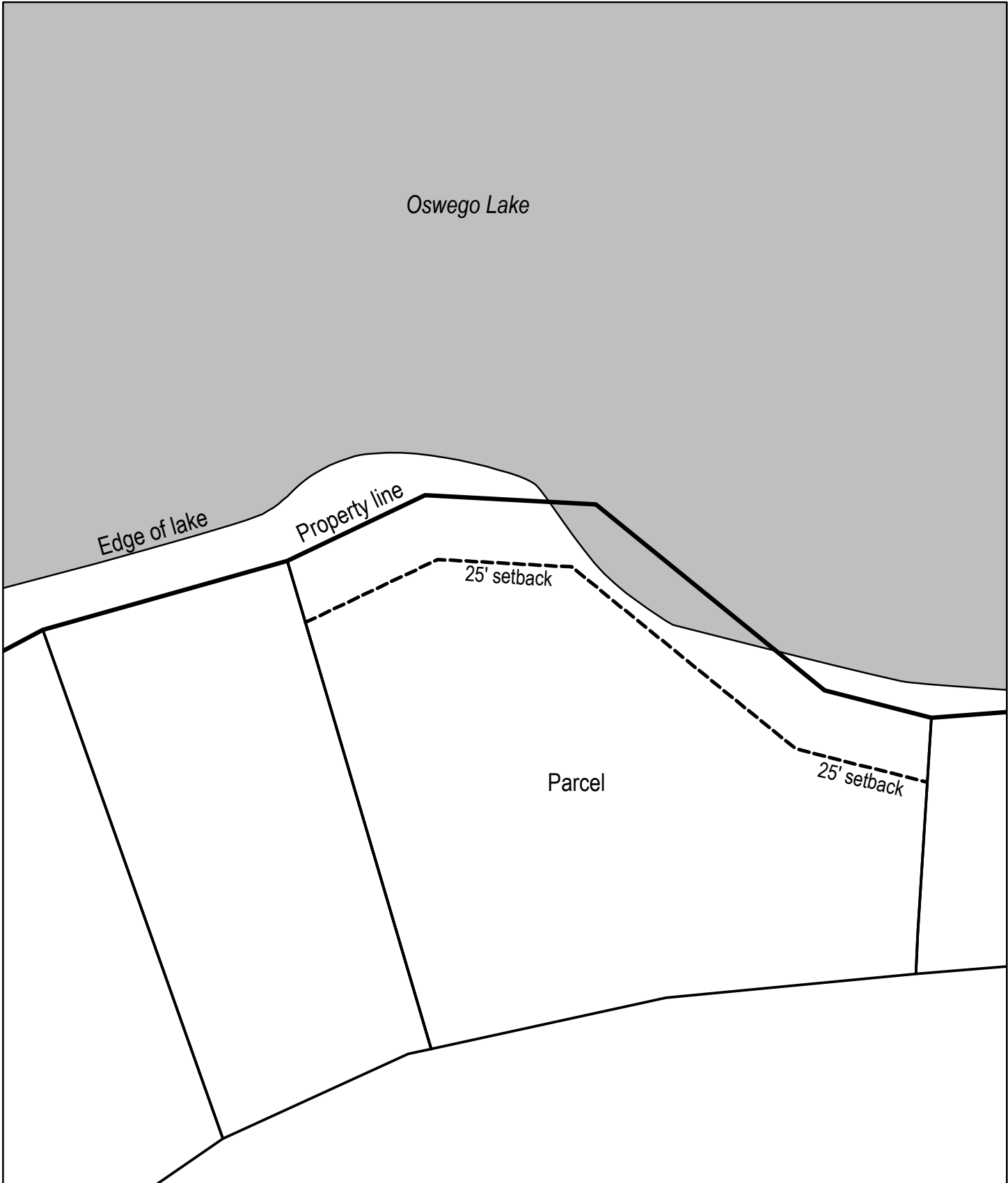

Appendix 50.22-A
Measurement of Oswego Lake Setback

May 2003, SCM/City of Lake Oswego

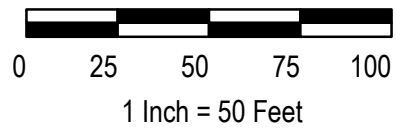

APPENDIX 50.44
FLOOD MANAGEMENT AREA

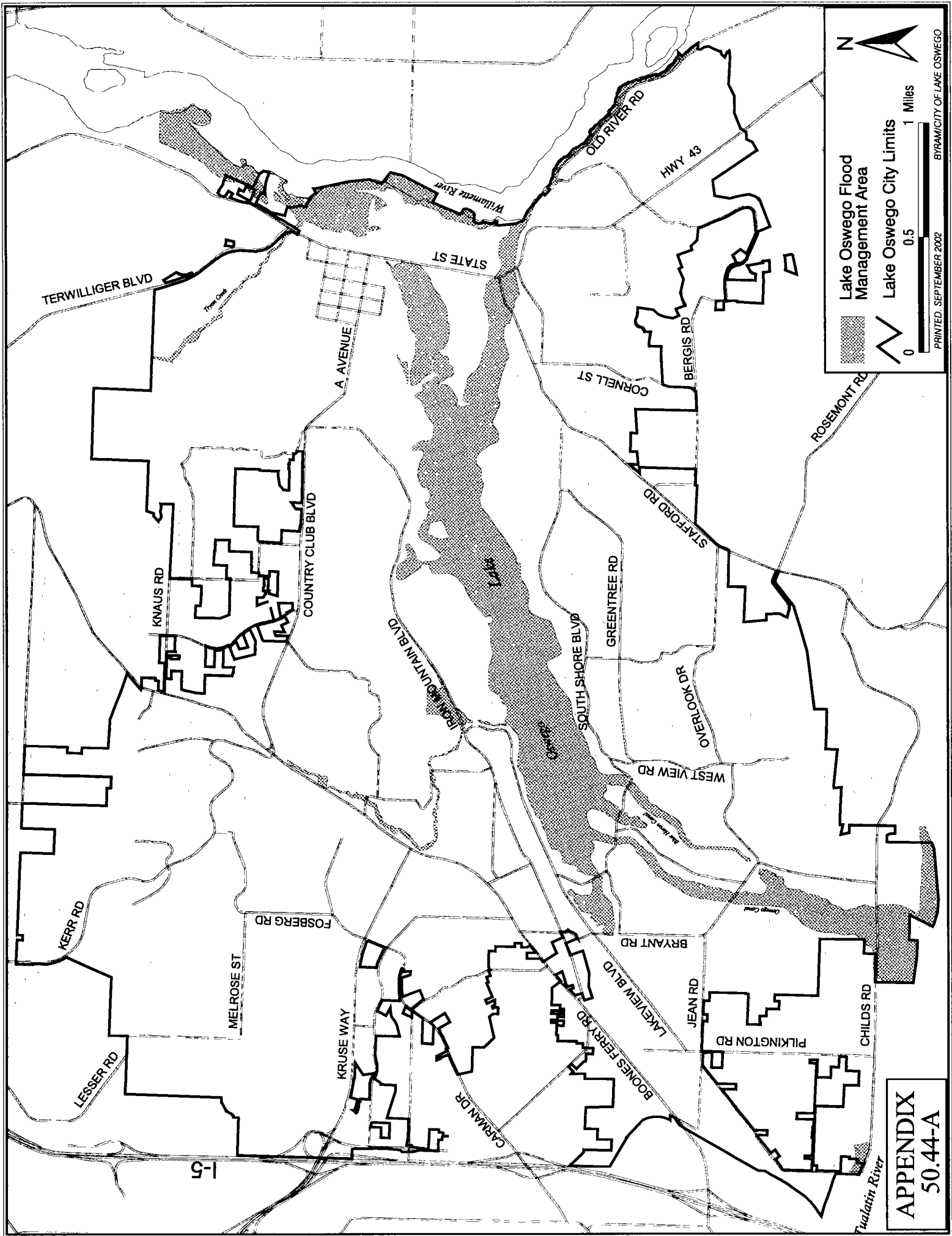

Lake Oswego Flood Management Area

Lake Oswego City Limits

1 Miles

0.5

0

PRINTED: SEPTEMBER 2002

BYRAM/CITY OF LAKE OSWEGO

APPENDIX
50.44-A

Paulatin River

I-5

TERWILLIGER BLVD

Trapp Creek

STATE ST

OLD RIVER RD
HWY 43

A AVENUE

BERGIS RD

CORNELL ST

ROSEMONT RD

COUNTRY CLUB BLVD

KNAUS RD

STAFFORD RD

IRAN MOUNTAIN BLVD

OVERLOOK DR

SOUTH SHORE BLVD

WEST VIEW RD

KERR RD

FOSBERG RD

GREENTREE RD

BRYANT RD

MELROSE ST

KRUSE WAY

JEAN RD

CHILDS RD

LESSER RD

CARMAN DR

LAKEVIEW BLVD

PILKINGTON RD

BOONES FERRY RD

Paulatin River

APPENDIX 50.55
PARKING STANDARDS

Appendix 50.55 - A
Minimum Off-Street Parking Space Requirements*

<u>Type of Use</u>	<u>Parking Spaces Required</u>
(A) <u>Residential</u>	
(1) Single-family dwelling and duplex	1 space per dwelling unit
(2) Secondary dwelling unit	1 space per unit (in addition to 1 space required for main dwelling unit)
(3) Multi-family	Twenty-five percent (25%) of the required parking for multi-family use shall be located to provide for common or visitor use
(i) Studio/Efficiency	1 space per unit
(ii) 1 Bedroom	1.25 spaces per unit
(iii) 2 or more Bedrooms	1.5 spaces per unit
(4) Rooming and boarding house; Bed and Breakfast	1 space per each guest room plus one for owner
(B) <u>Commercial Residential</u>	
(1) Hotel or Motel	1 space per unit
(2) Assisted living facility	0.5 space per unit plus one per three employees
(3) Hospital	1.5 spaces per bed
(C) <u>Places of Public Assembly</u>	
(1) Churches, clubs, lodges, meeting rooms and auditoria	1 space per 4 seats of maximum capacity, or 1 space for each 5 occupants based on maximum capacity as calculated under the provisions of the Uniform Building Code
(2) Library, reading room, museum, art gallery	1.88 spaces per 1,000 square feet plus one space per two employees on the peak shift
(3) Nursery, day or child care facility, kindergarten	2.5 spaces per 1,000 square feet G.F.A.

APPENDIX 50.55 - A

(4) Elementary or middle school, or equivalent private or parochial school	16.6 spaces per 1,000 square feet G.F.A. in the auditorium or 2 spaces per classroom, whichever is greater
(5) Senior high and equivalent private or parochial school	.2 space per number of students and staff
(6) College; Commercial school for adults	3 spaces per 1,000 square feet G.F.A. (excluding dorms)
(7) Schools such as martial arts, music, dance, gymnastics	1 space per 100 square feet G.F.A. of lesson activity floor area plus .5 space per employee
(D) <u>Commercial Amusements</u>	
(1) Stadium, arena, theater	1 space/4 seats (fixed seating)
(2) Bowling alley	3 spaces per lane plus .5 space per employee
(3) Sports club/Recreation facilities, including billiard and pool parlors, video arcades, dance hall, gymnasium, health club	2 spaces per 1,000 square feet G.F.A.
(E) <u>Commercial</u>	
(1) Office, including business and management services, except medical or dental	3.33 spaces per 1,000 square feet G.F.A.
(2) Medical and Dental Offices or clinics including accessory laboratories for medicine, dentistry, veterinarian practice or other practices of the healing arts	3.9 spaces per 1,000 square feet G.F.A.
(3) Bank	2.5 spaces per 1,000 square feet G.F.A.
(4) Supermarket	2.9 spaces per 1,000 square feet G.F.A.
(5) Convenience food store	2.2 spaces per 1,000 square feet G.F.A.
(6) Specialty food stores, such coffees, <i>bagels, juice bars</i> (Take-out food/drink primarily)	6.6 spaces per 1,000 square feet G.F.A.
(7) Eating or drinking establishment	13.3 spaces per 1,000 square feet G.F.A.

APPENDIX 50.55 - A

- | | |
|--|---|
| (8) Eating or drinking establishment with drive up window | 9.9 spaces per 1,000 square feet G.F.A. |
| (9) Barber shop, beauty salon, personal care services, such as nail, tanning, and therapeutic massage salons | 4 spaces per 1,000 square feet G.F.A. plus .5 space per station |
| (10) Retail sales and rentals, except as otherwise specified herein | 3.3 spaces per 1,000 square feet G.F.A. |
| (11) Heavy equipment rentals, such as yard and tool equipment | 1 space per 1,000 square feet G.F.A. plus .5 space per employee |
| (12) Service or repair shop, such as electronic and home appliance repair, upholstery | 1.6 spaces per 1,000 square feet G.F.A. |
| (13) Automotive repair garage and service station | 1.6 spaces per 1,000 square feet G.F.A. plus .5 space per employee |
| (14) Mortuary | 1 space per five seats based on maximum auditorium capacity plus .5 space per employee |
|
(F) <u>Bulk merchandise</u> | |
| (1) Furniture, appliance store building materials | 2 spaces per 1,000 square feet G.F.A. |
| (2) Auto, boat or trailer sales | 1 space per 1,000 square feet G.F.A. of building plus .5 space per employee |
| (3) Truck, trailer and automobile rental parking lot | .75 space per employee on largest shift |
|
(G) <u>Industrial</u> | |
| (1) Light industrial, industrial park, Manufacturing | 1.6 spaces per 1,000 square feet G.F.A. |
| (2) Storage, warehouse, wholesale establishment, freight terminal, truck or auto storage | 1 space per 1,500 square feet G.F.A. or .75 space per employee based on maximum shift, whichever is greater |
| (3) Mini-storage facility | 3.33 spaces per 1,000 square feet of gross office floor area plus one space for resident manager |
|
(H) <u>Uses Not Specifically Mentioned</u> | |

APPENDIX 50.55 - A

Parking requirements for uses not specifically mentioned in this section shall be determined by the requirements for off-street parking facilities for the listed use which, as determined by the City Manager, is most similar to the use not specifically mentioned, or by a parking study.

*NOTE:

Per LOC 50.55.010 (1)(b)(i)

Fractional space requirements shall be counted as the next highest whole space.

Per LOC 50.55.010(1)(b)(ii)

Except for residential parking requirements, the maximum number of parking spaces shall not exceed 125 percent of the minimum number of required spaces.

Appendix 50.55 - B
Off-Street Parking Matrix
Required Space and Aisle Dimensions in Feet

COMPACT SIZE VEHICLES						STANDARD SIZE VEHICLES				
Angle (A)	Stall Width (B)	Stall Depth (C)	Aisle Width (D)	Module Width (E)	Bumper Overhang (F)	Stall Width (B)	Stall Depth (C)	Aisle Width (D)	Module Width (E)	Bumper Overhang (F)
0°(parallel)	8.0	20.0	N/A	N/A	N/A	8.0	24.0	N/A	N/A	N/A
45°	8.0	15.5	11.0	42.0	2.0	8.5	17.5	13.0	48.0	2.0
60°	8.0	17.0	14.0	48.0	2.5	8.5	19.0	18.0	56.0	2.5
75°	8.0	17.5	21.0	56.0	2.5	8.5	19.5	25.5	64.5	2.5
90°	8.0	16.0	20.0	52.0	1.5	8.5	18.5	26.0	63.0	2.5
						9.0	18.5	24.0	61.0	2.5

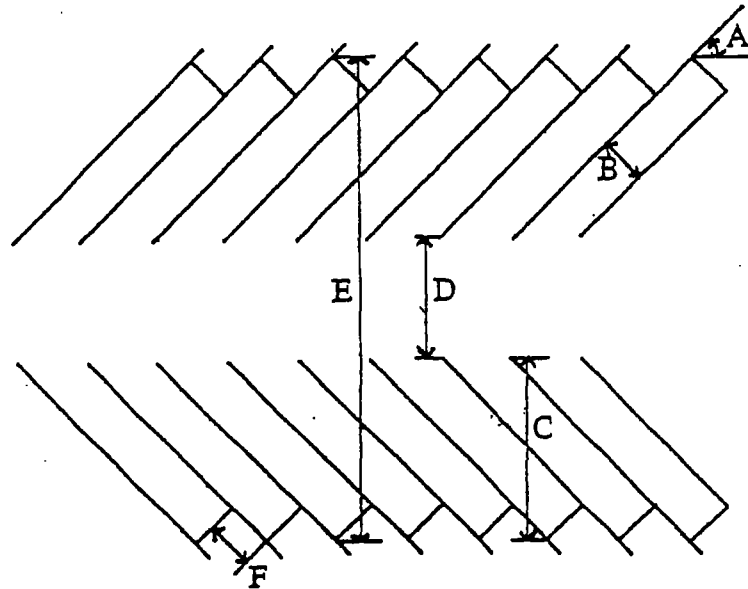

A	Parking Angle	E	Module Width (no bumper overhang)
B	Stall Width	F	Bumper Overhang
C	Stall Depth (no bumper overhang)		
D	Aisle Width between Stall Lines, except for fire lanes, which are regulated by LOC Chapter 15, "Fire Protection".		

**Appendix 50.55 – C
Parking Requirement Modifiers**

Reduction for Access to Transit Facilities

Commercial and Industrial Uses (Based on Development Size on a Single Site (DS))

<u>Gross Floor Area</u>	<u>Multiplier</u>
0 – 20,000 square feet	No reduction
20,000 plus square feet	.85 x requirement

Availability of Transit Access (TA)

Transit shelter more than 500 square feet of building	No reduction
Transit available with shelter within 500 feet of building	.95 x requirement
Transit available on fronting street without shelter	.90 x requirement
Transit available on fronting street with shelter within 50 feet of building	.85 x requirement

Reduction for Pedestrian and Bicycle Access (PA)

Commercial and Industrial Uses	<u>Multiplier</u>
No hard surfaced pedestrian/bicycle access	No reduction
Hard surfaced pedestrian and bicycle access to 100 or more residential units within 1000 feet of the site.	.90 x requirement

Reduction Permitted within the Downtown Redevelopment District

Refer to Lake Oswego Development Standard Article 50.65, *Downtown Redevelopment District Design Standard*, [LOC 50.65.055] for special parking requirement modifications permitted within the District.

Reduction Permitted Based on Parking Study

The Parking Study shall demonstrate sufficient number of parking spaces:

- a. For shared parking with other multiple users per LOC 50.55.010(1)(d)(ii)
- b. Based on similar uses elsewhere in the City or the same use at other sites.

Parking requirement modification shall be calculated as followed: Minimum requirement by type use x DS (Development Site) x TA (Transit Access) x PA (Pedestrian Access) = modified parking requirement.

Definitions:

Transit Access: Availability of transit service as delineated above.

Pedestrian Access: The means by which pedestrians have safe, adequate and usable ingress and egress to a property or use.

Appendix 50.55 – D

Minimum Required Bicycle Parking Spaces

Use Categories	Specific Uses	Number of Required Spaces
<u>Residential Categories</u>		
Household Living	Multi-family	1 per 4 units
Group Living		2, or 1 per 20 residents
	Dormitory	1 per 8 residents
<u>Institutional Categories</u>		
Preschool		2, or 1/2 per classroom
Schools	Grades 1 through 12	2 per classroom
Colleges	Excluding dormitories (see Group Living, above)	2, or 1 per 20,000 square feet G.F.A.
Transit Centers	Park & Ride Lots	5% of auto spaces
Religious Institutions		2, or 1 per 4,000 square feet G.F.A.
Hospitals		2, or 1 per 40,000 square feet G.F.A.
Libraries, Museums, etc.		2, or 1 per 4,000 square feet G.F.A.
<u>Commercial</u>		
Retail Sales and Services	includes Groceries and Financial Institutions	2, or 1 per 2,500 square feet G.F.A.
Auto-oriented Services	with or without Mini-Market	2, or 1 per 5,000 square feet G.F.A.
Office	includes Doctor, Dentist	2, or 1 per 5,000 square feet G.F.A.
Restaurant	includes Drive-Ins	2, or 1 per 5,000 square feet G.F.A.
Theaters, Auditoriums		1 per 60 seats
<u>Industrial Categories</u>		
Warehouse & Freight Movement		2, or 1 per 40,000 square feet G.F.A.
Manufacturing & Production		2, or 1 per 15,000 square feet G.F.A.
Industrial Park	Other than manufacturing & warehousing	2, or 1 per 10,000 square feet G.F.A.

NOTES:

1. Wherever this table indicates two numerical standards, such as 2, or 1 per 3,000 sq. ft. of gross floor area, the larger number applies.
2. One hundred percent (100%) of all required bicycle parking spaces for residential and industrial categories shall be covered. These bicycle parking spaces may be provided within a building. Bicycle parking spaces for employees of commercial, public use, and institutional categories are encouraged to be covered and secured. Cover for bicycle parking may be accommodated by building or roof overhangs, awnings, bicycle lockers, bicycle storage within buildings or dwelling units or free standing shelters. [LOC 50.55.010 (2)(f)]
3. Fractional space requirements shall be counted as the next highest whole space. [LOC 50.55.010 (1)(B)(i)]
4. G.F.A. (Gross Floor Area): The area included within the surrounding exterior walls of a building or portion thereof excluding allowable projections, decks, patios, uncovered exit stairways or uncovered above-grade driveways. [LOC 50.02.005]

APPENDIX 50.60
LOCAL STREET CONNECTIVITY

Appendix 50.60-A
Local Street Connectivity

Street Feasible

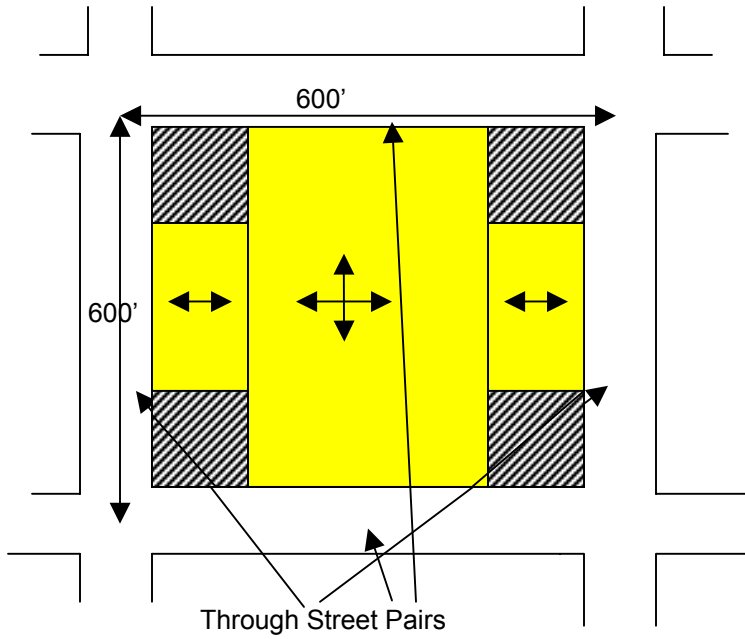

Standards do not apply
(within 100' of through
streets)

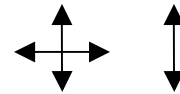

Direction of required
connectivity



Property subject to
Planning requirement



Existing Accessway



Barrier to street
construction (i.e.,
wetland)

Street Not Feasible

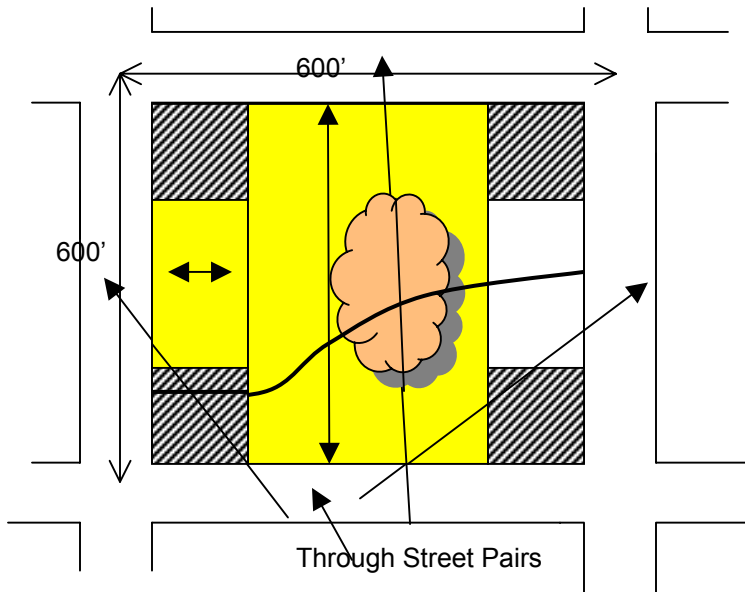

APPENDIX 50.65
DOWNTOWN REDEVELOPMENT DISTRICT
DESIGN STANDARDS

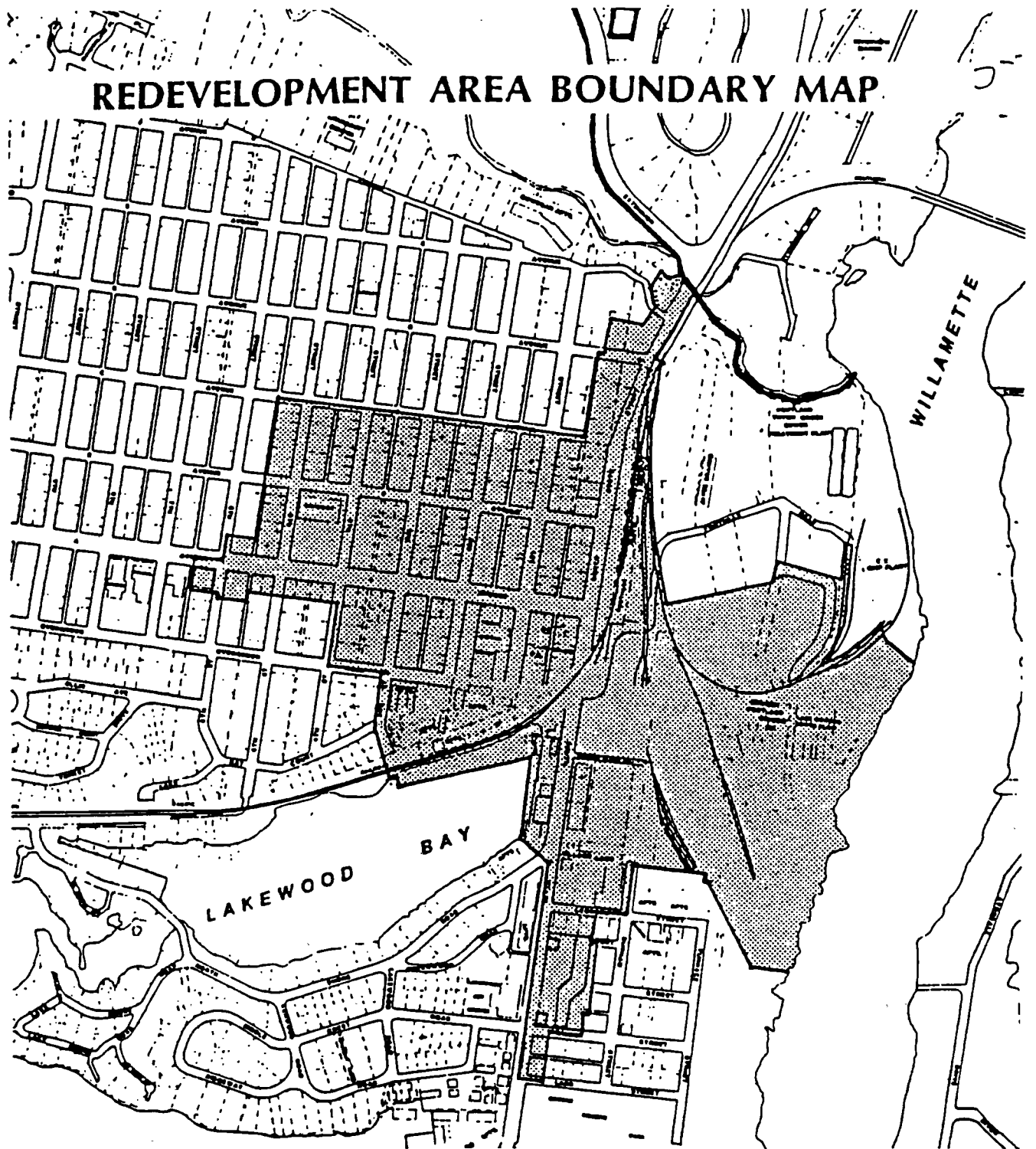

Arts & Crafts Style

1900-1920

The Arts and Crafts movement originated in England in the 1880s when the designer William Morris (1834-1896) began writing and lecturing about the need for a “new birth” of the arts. He rejected classically inspired art and looked instead to the Middle Ages, local traditions, and nature for inspiration and subject matter. According to Morris, art was for everyone, not just the wealthy, and everyone was a potential artist or craftsperson. He feared that the prevailing doctrine of “art for art’s sake” was causing artists to lose touch with real people and life, and that his attitude would eventually kill art’s vitality. Ardent and articulate in his views, he persuaded others to look at common objects such as furniture, metalwork, wallpaper, textiles, and houses and subjects worth of artistic expression. His philosophy became so influential that the Arts and Crafts Society was formed; it espoused the virtues of natural materials and fine craftsmanship, encompassed all aspects of design, and elevated the crafts to the status of art.

Although Morris was not an architect, he influenced many creative English architects, including Philip Webb (1831-1951) who designed Morris’s house, known as the Red House, in 1859. The design, modeled after local Gothic vernacular houses, was considered radical because vernacular houses were generally regarded as inferior and unworthy of emulation. The ideals of the Arts and Crafts movement – love of nature, and respect for the common man and craftsmanship – led many architects of the time to base their designs on traditional, rather than classical, houses built by country people out of available materials.

Two other English architects, C.F.A. Voysey (1857-1941) and Sir Edwin L. Lutyens (1869-1944), also influenced the architecture of the Arts and Crafts movement. Voysey, who also designed furniture, wallpapers, and fabric, simplified and adopted English country house designs, creating a “new” usually smaller home for middle-income families. His work was published in Europe and the United States throughout his life. The Wade Pipes House (120), in Portland, with the medieval roof pitch of forty-five degrees, and the low opposing slopes of the two gables, clearly shows Voysey’s influence.

*The style descriptions are borrowed from the book Architecture, Oregon Style.

Characteristic Elements of the Style

Steeply pitched gable roof, often with intersecting or double gable dormers, or with one slope occasionally sweeping close to the ground.

Prominent chimneys.

Asymmetrical composition, generally rectangular, with roof, window and porch projections.

Casement and sash windows with many small panes, segmental and round arched openings used for accent.

Stucco, shingle, brick, or horizontal siding sometimes used in combination.

Simplified English vernacular elements such as simulated half-timbering and simulated thatched roofs.

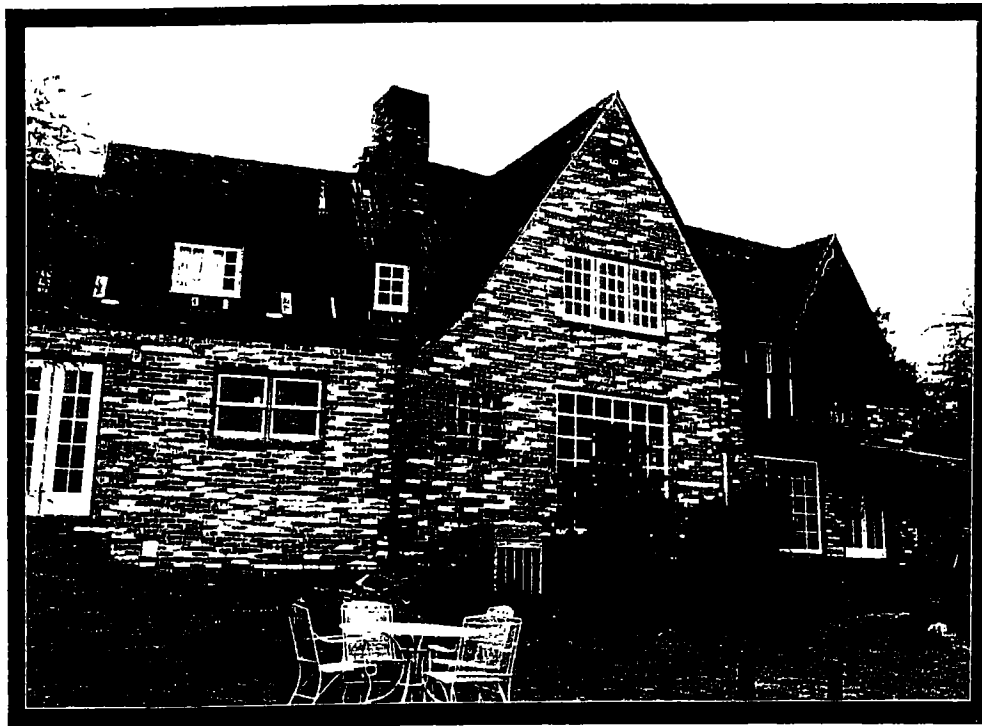

Arts & Crafts Style
919 West Point Road

English Tudor 1910-1935

Characteristic Elements of the Style

Steeply pitched gable roof, often with double gable dormers, or lower roofs behind ornamental parapets.

Prominent fluted chimneys.

Rectangular shape with vertical projections.

Bay, oriel, dormer, and many-paned windows, sometimes with leaded glass.

Brick construction, with bricks sometimes set in intricate designs; wood-frame construction, with stucco finish; or a combination of brick and stucco construction.

Tudor-arched or round-arched openings, especially in the entrance door; quatrefoil or medieval designs in decorative trim; imitation half-timbering. Brick buildings have contrasting stone moldings.

The English Tudor style was one of the most popular styles in the years following the First World War. Wealthy Americans were attracted to the English country manor house and used it as the model for their suburban homes. The characteristic half-timbering, usually only a superficial design placed upon a stucco wall, was based on the medieval tradition, which called for heavy timber framing with wattle and daub (a mud-and-straw or twig mixture) or brick infilling between the timbers. The sources for this fashion are to be found in English buildings of the sixteenth and early seventeenth centuries. Good examples can be found in most towns and cities throughout the state.



737 Country Club Road English Tudor

Oregon Rustic Style 1915-1940

Characteristic Elements of the Style

Moderately pitched hipped and gable roofs, sometimes in combination.

Large stone chimneys.

Asymmetrical composition.

Numerous small windows with many panes and simple undecorated frames, dormer windows.

Log construction, unpeeled logs or half-round logs applied as siding; board-and-batten or shingled siding left unpainted; natural materials such as river boulders or rough stone used in foundations or as siding for first-floor levels.

Handcrafted rustic decorative elements: carved newel-posts, handwoven textiles, log or bent-twig furniture.

The Oregon Rustic style is comparable to the National Park style used for the lodges and buildings in national parks around the country. These buildings, designed to harmonize with their forested settings, used natural materials such as logs and local stone, and sometimes emulated the look of pioneer or folk architecture. They resemble early log buildings but differ from them in their self-conscious use of rustic elements. The Rustic style was also influenced by the Great Camp architecture of the Adirondacks, a style used in resorts built for very wealthy American families between the 1880s and the 1920s. The buildings of these resorts were mansion-like wooden structures that used logs for siding, branches for posts, and other rustic materials for furniture and decorative details.

Perhaps the first Rustic style building in Oregon was Cloud Cap Inn, built on Mount Hood in 1889. Its design by William H. Whidden featured log construction, a stone chimney, and a wood shake roof, trademarks of the style.

Crater Lake Lodge, built in 1914 with additions in 1924, and Oregon Caves Chateau, built in 1934, were both constructed in the National Park tradition. Timberline Lodge, built on Mount Hood between 1936 and 1938 as a Works Progress Administration (WPA) project, is the finest example of the Oregon Rustic style. The Timberline project employed some of Oregon's most noted craftsmen and artists, and remains today as a monument to their skills.

The United States Forest Service used this style in ranger stations, shelters, and lookouts in the early 1900s. During the Great Depression, the Civilian Conservation Corps (CCC) adopted the style in the many structures it built in recreation areas across the country.

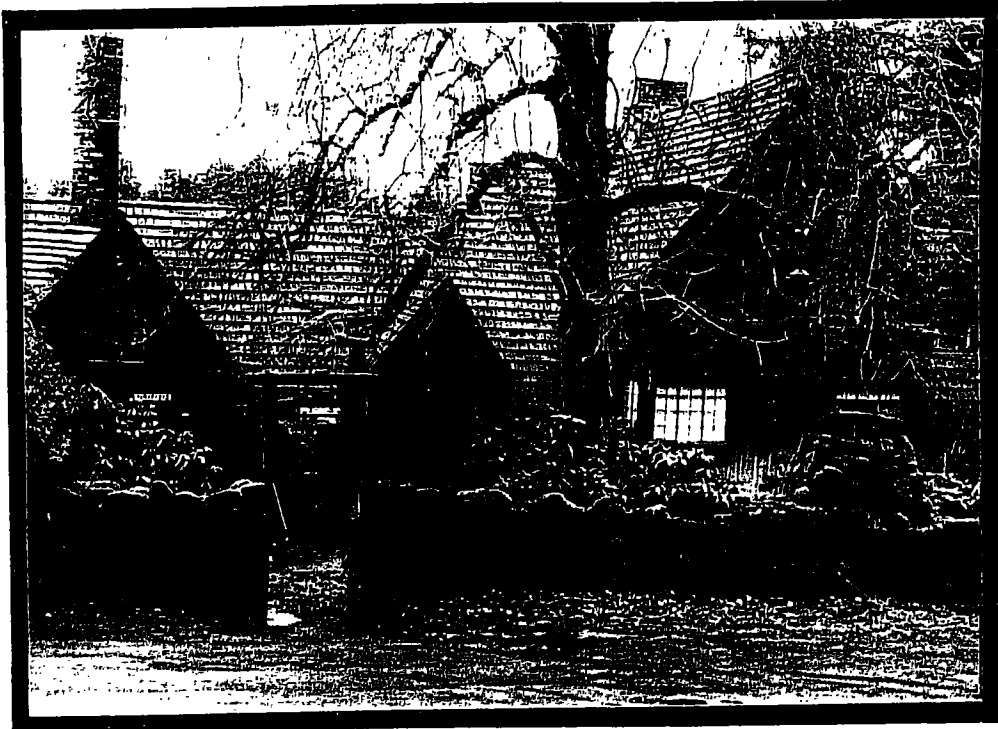

16722 Greenbriar Oregon Rustic



16865 Greenbriar Oregon Rustic



409 Edgecliff Road English Tudor



1515 Cherry Lane Arts & Crafts

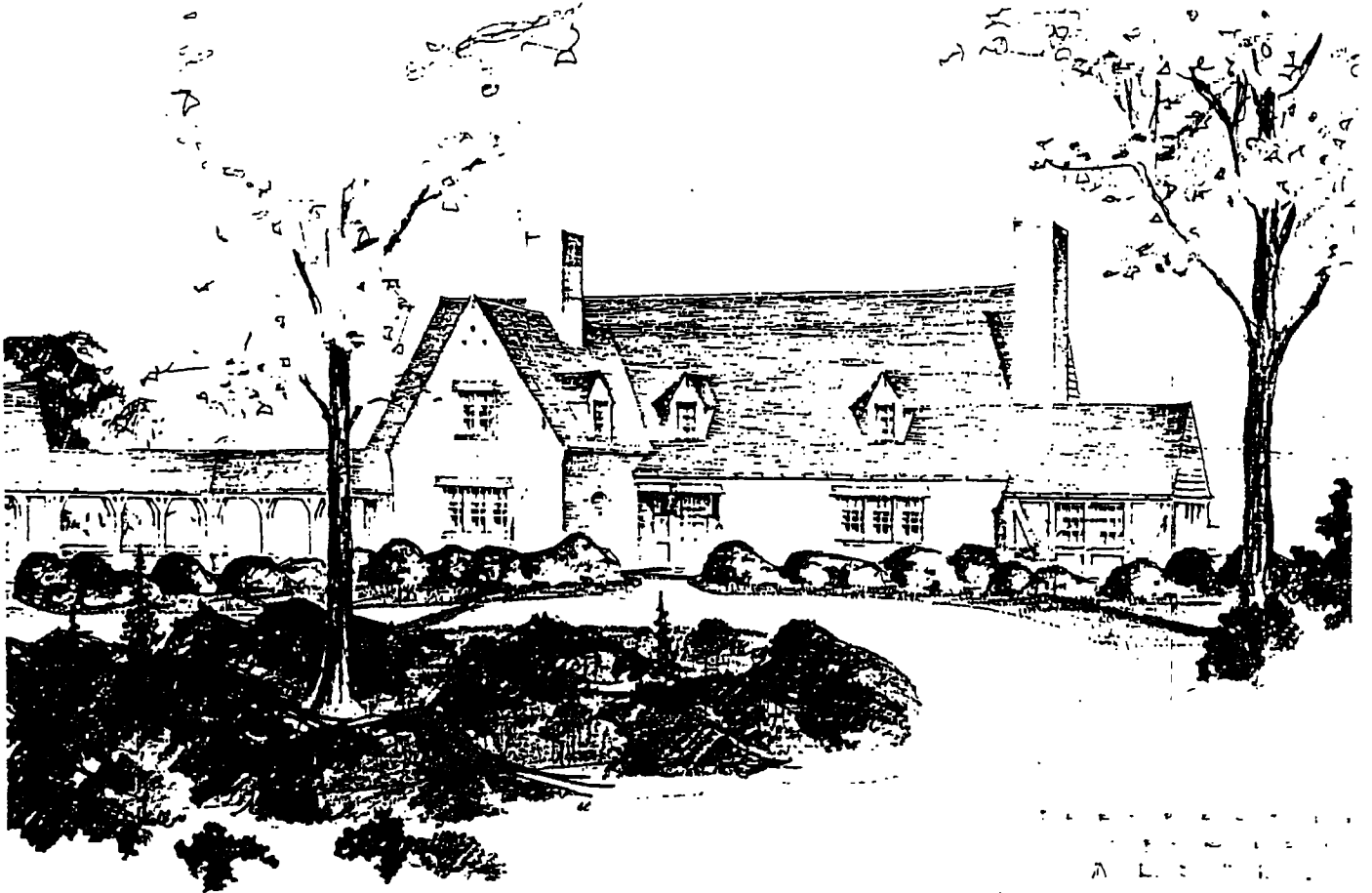

THE HOUSE IS
DESIGNED
AS A PLACE
FOR THE
LARGE FAMILY
AND FOR THE
GUESTS.

4375 South Shore Blvd. Arts & Crafts



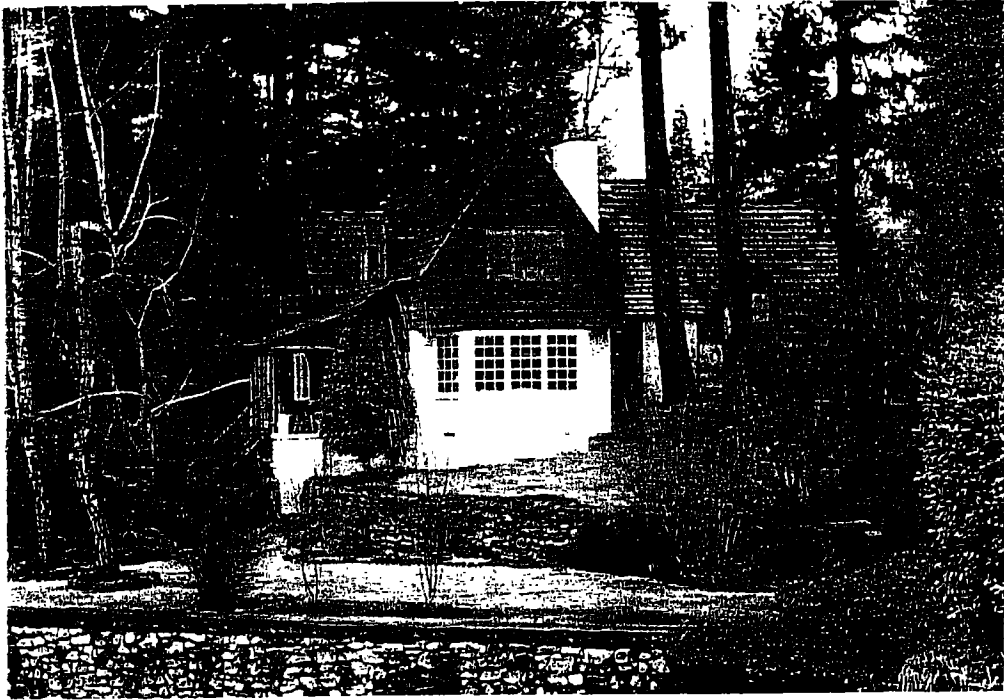

768 North Shore Road Arts & Crafts

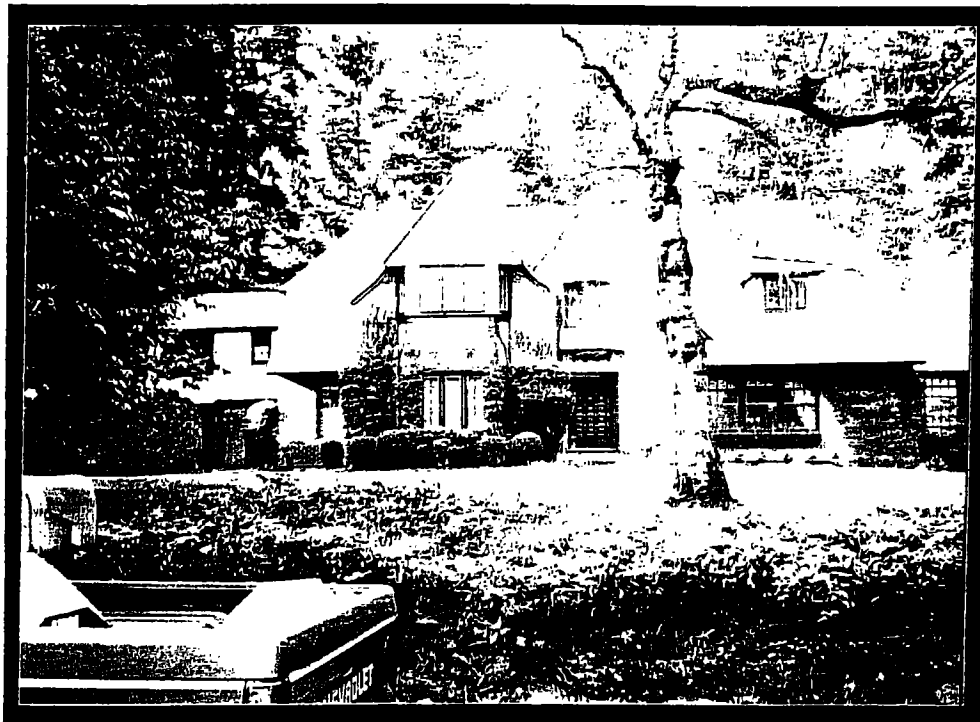

1097 Chandler Road English Tudor



876 North Shore Road Oregon Rustic



1650 North Shore Road English Tudor

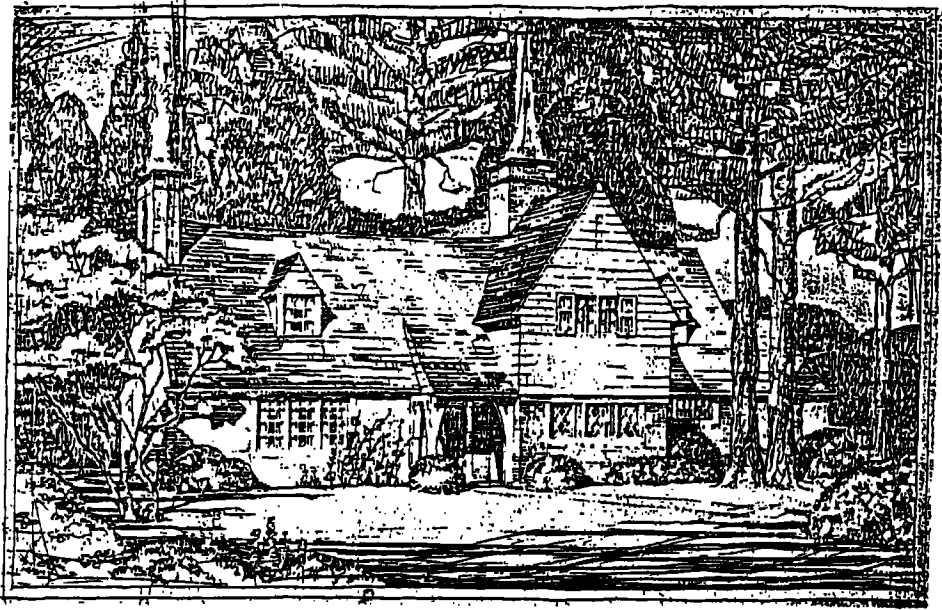

1125 Maple Arts & Crafts



13100 Riverside Drive Arts & Crafts

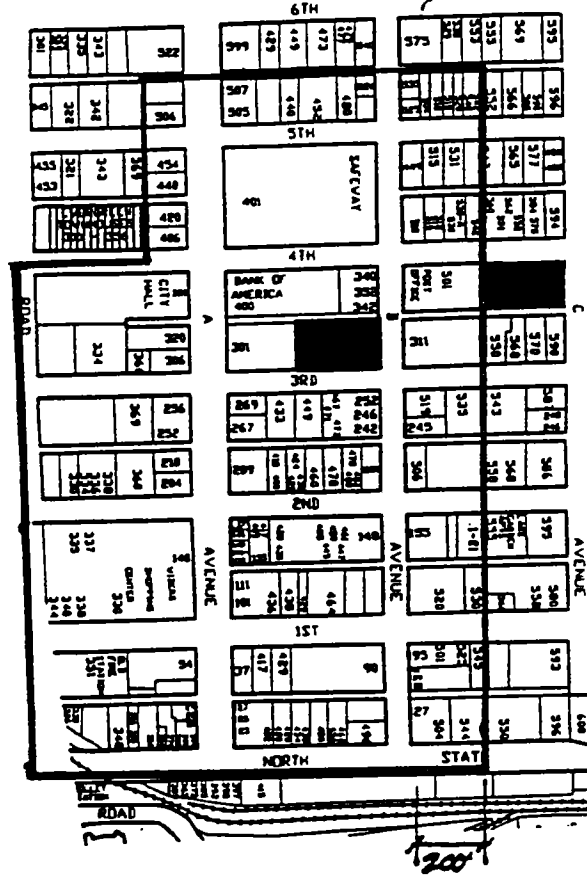

Figure 1

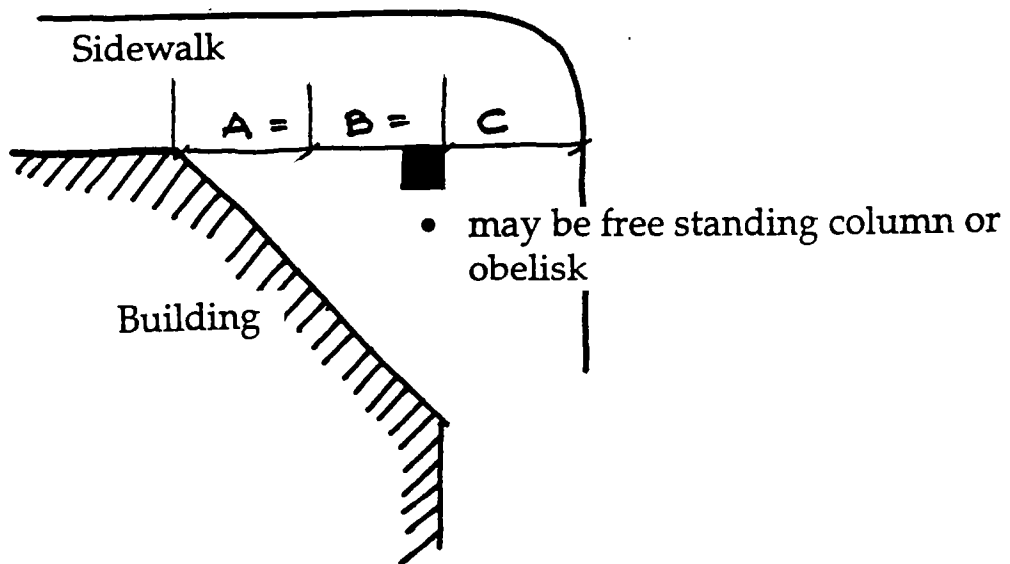
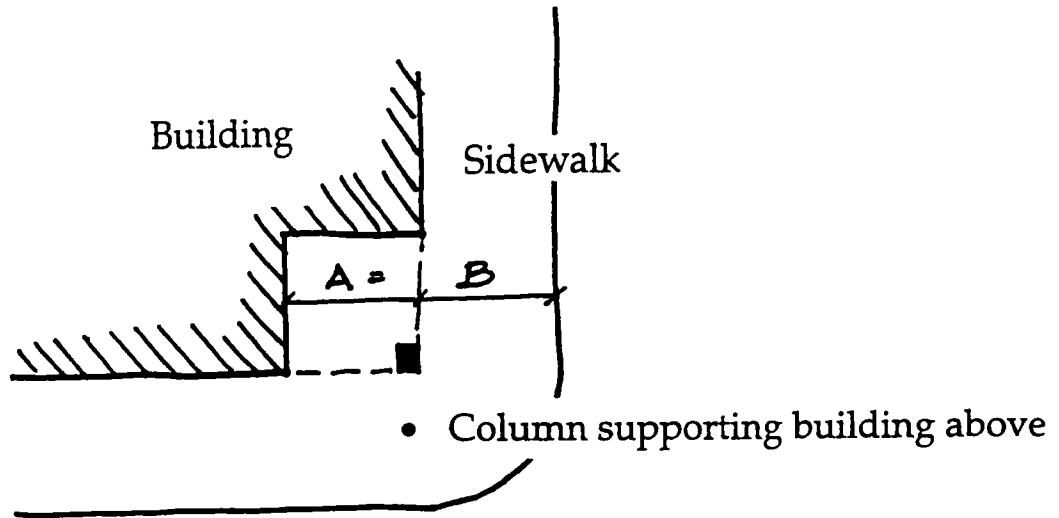
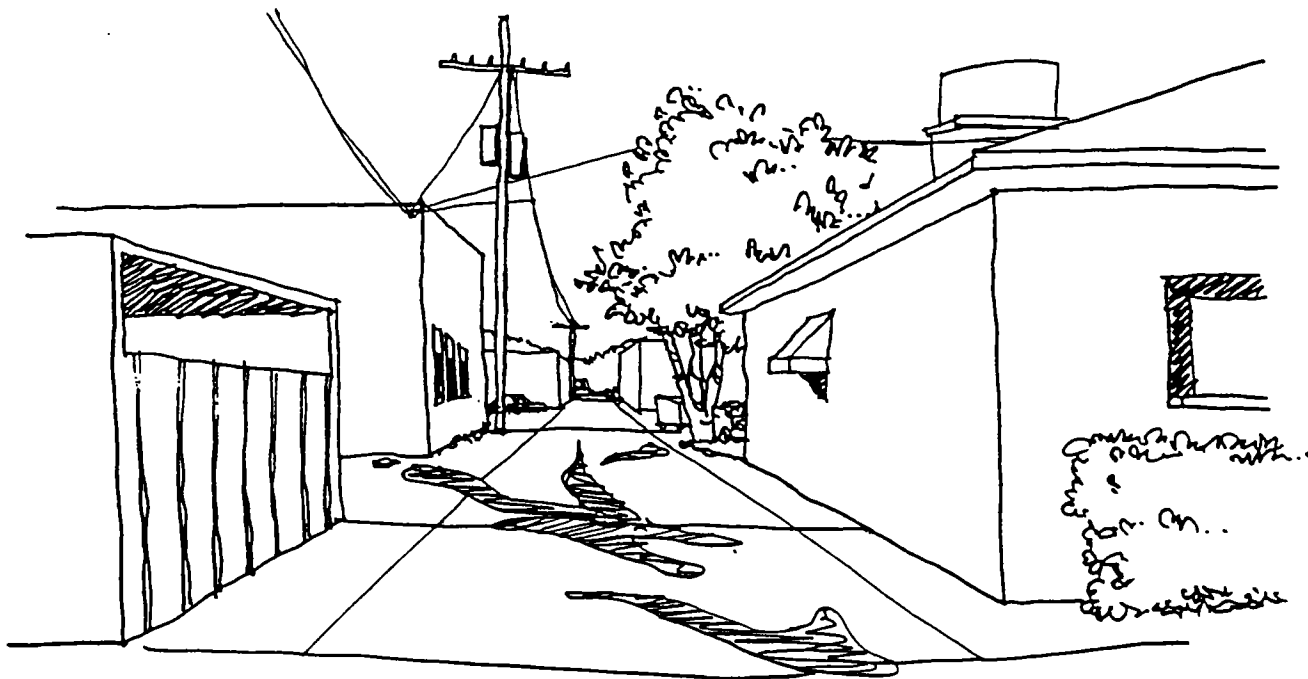
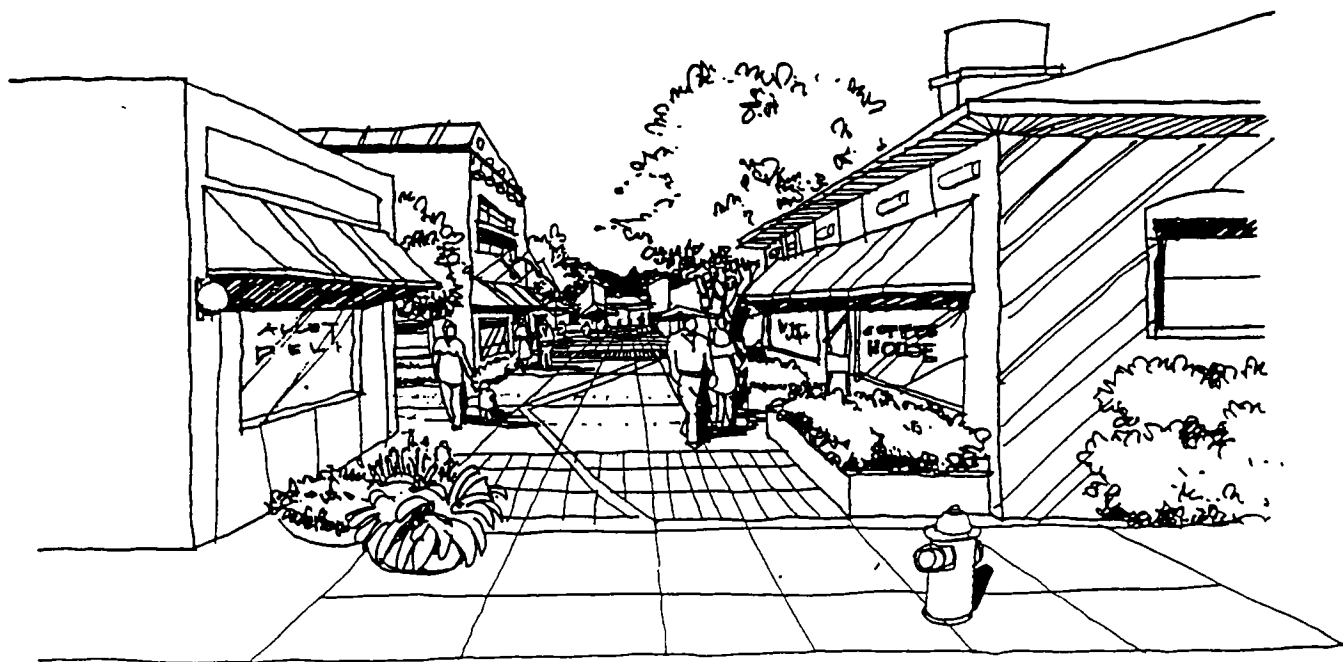

Figure 2



ALLEY (BEFORE)



ALLEY (AFTER)

Figure 3



- Shed type awning with open end (above) and closed end below. Both with valance.
- Storefront appearance at ground level.
- Brick pavement panel (below)

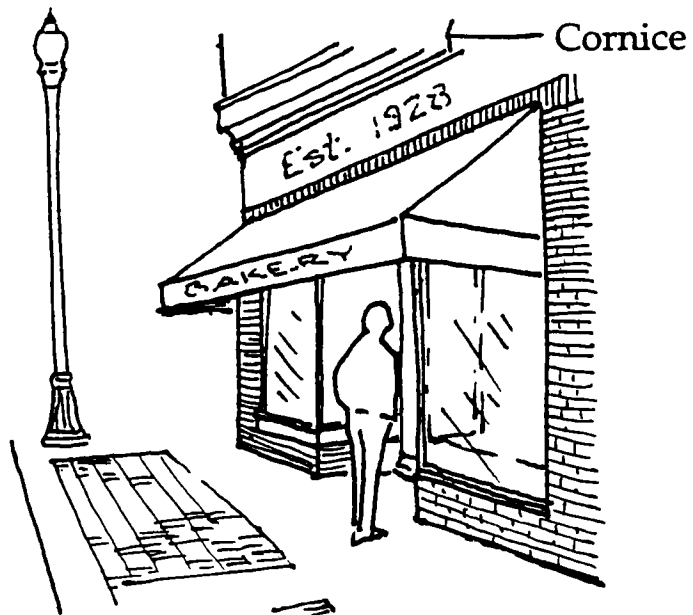
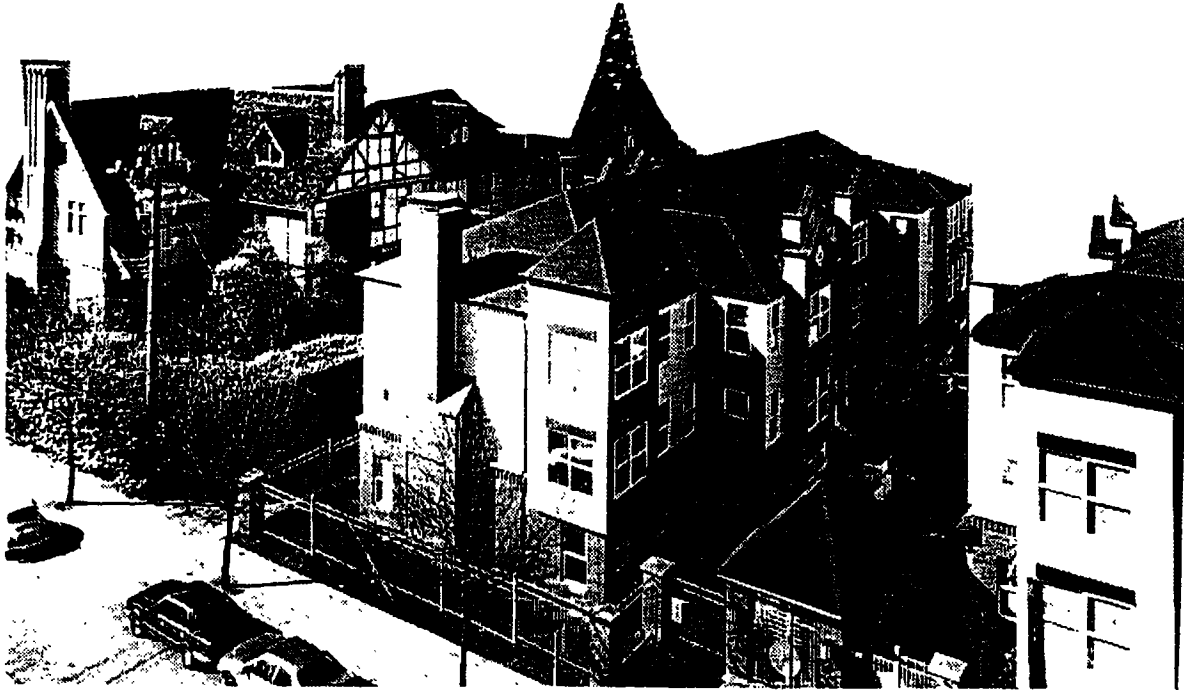

Figure 4



- Mixed use structures - retail below/office or residential above.
- Stepped cornice due to slope.
- The Gable roofed building is masonry at lower level to establish a strong visual base.
- The flat roofed building is all masonry.
- Signage opportunities on awnings and in cornice band or hanging above cornice.

Figure 5



New buildings borrow from the adjacent English Tudor Building.

Note complimentary massing, roof forms, masonry chimney and building base. One site defines the street with a hedge, the other with a masonry and metal fence.

Figure 6

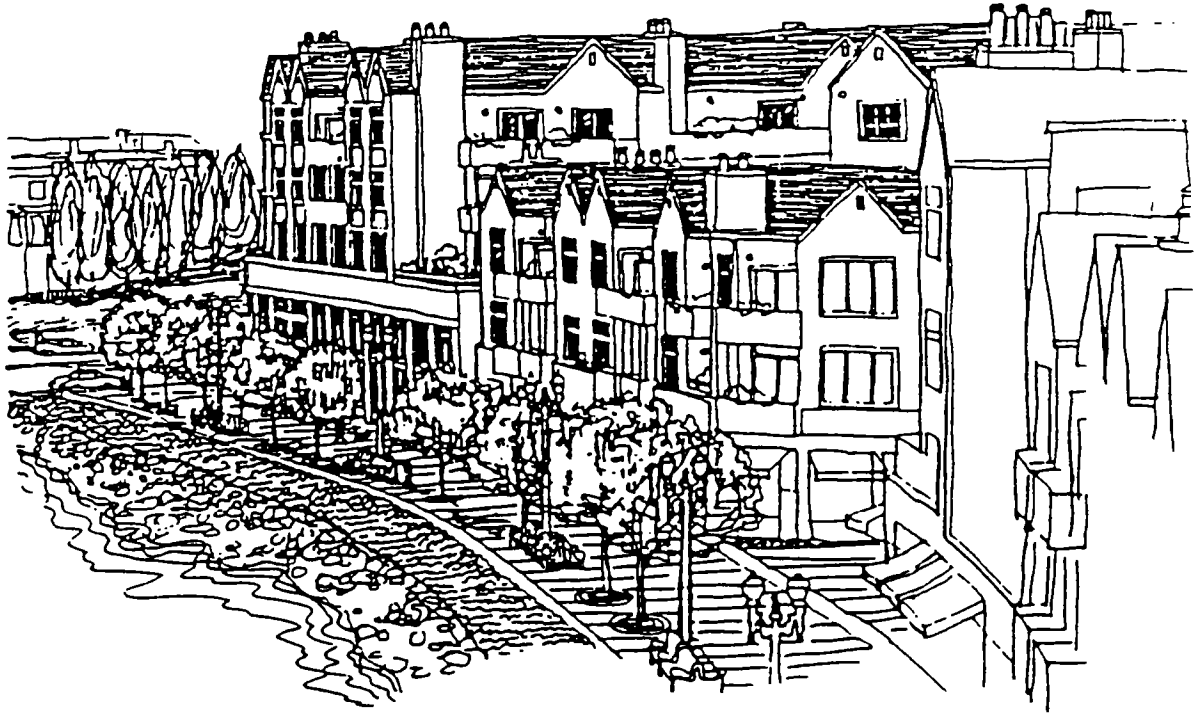

Riverplace in Portland - a successful mixed-use project along a public promenade.

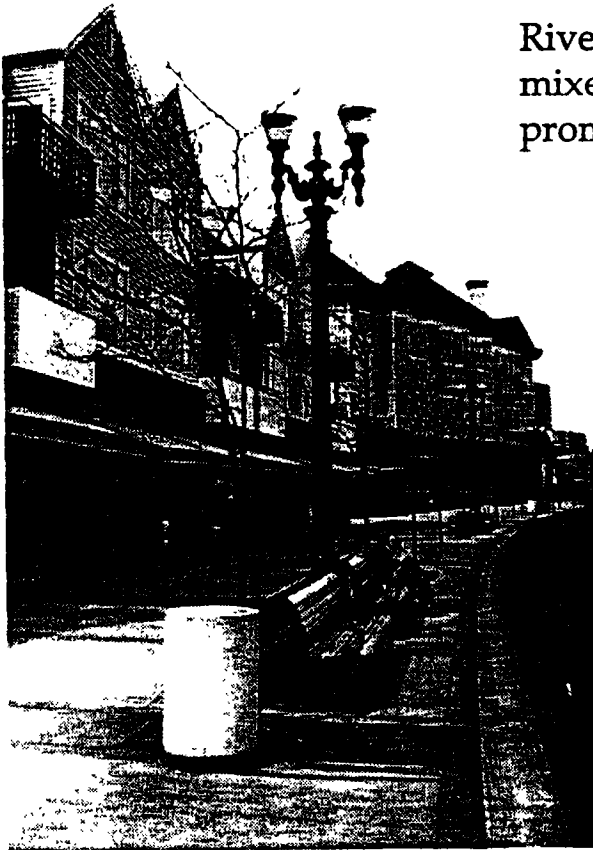

Figure 7

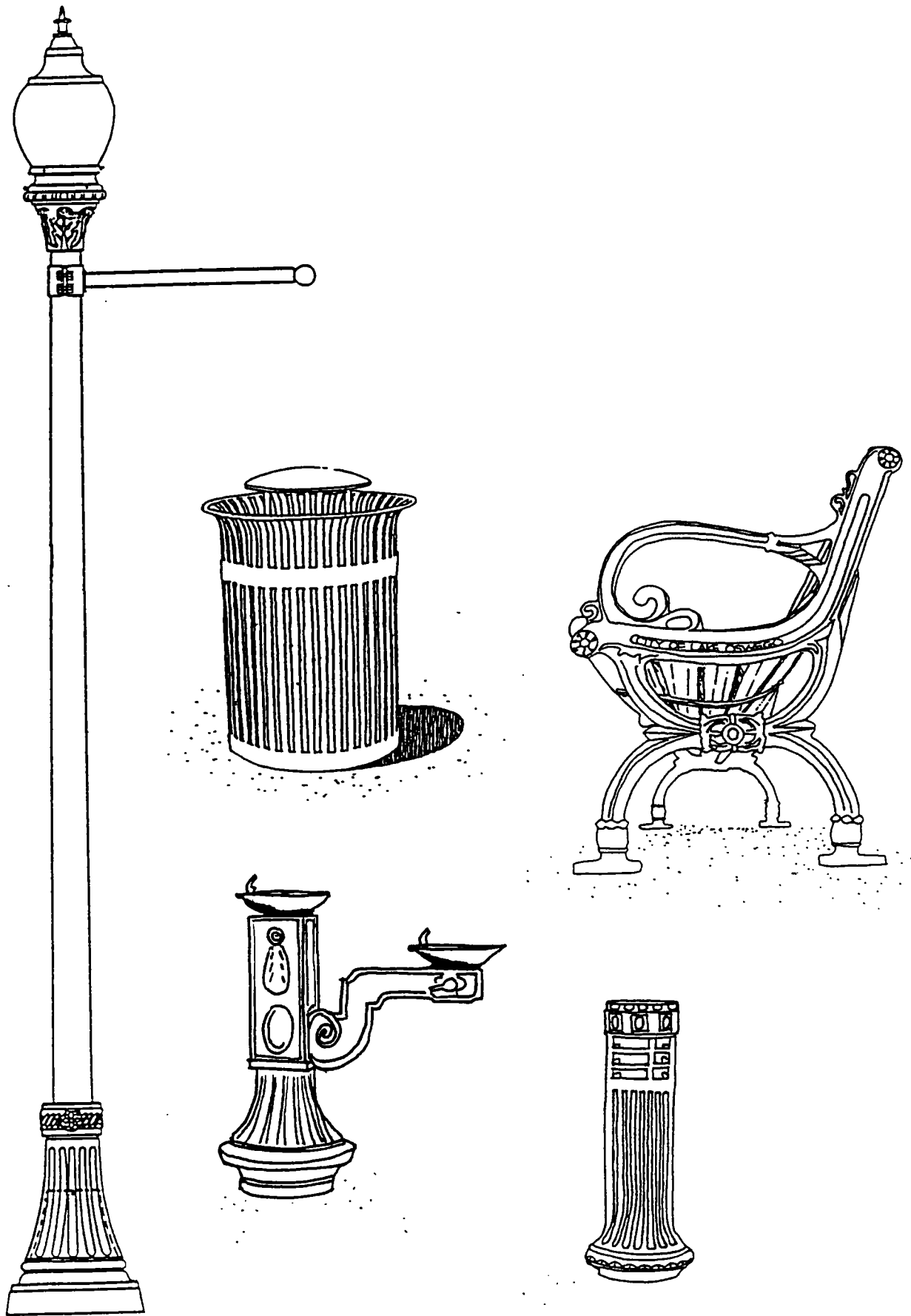
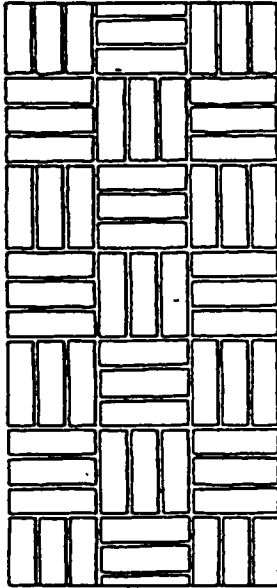

Figure 8

Brick

Basket Weave



Herringbone

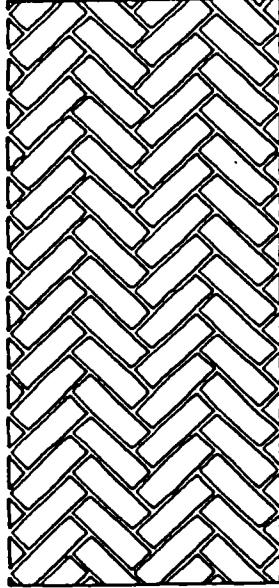

Running

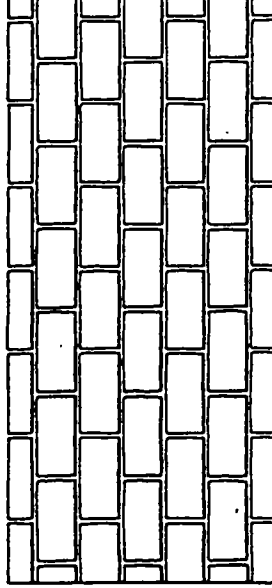

Cross

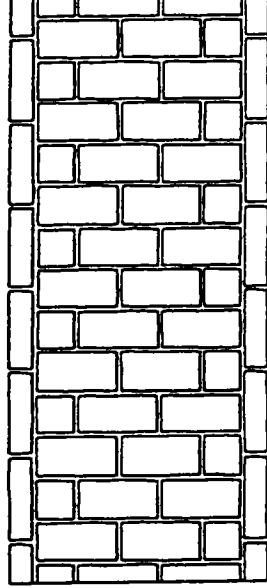

Diagonal

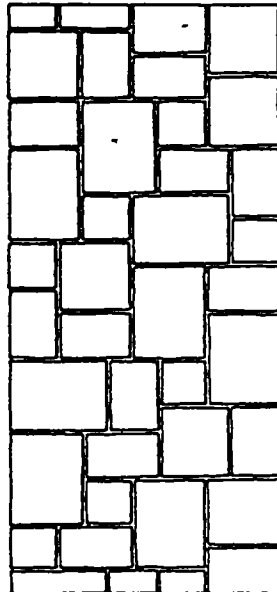
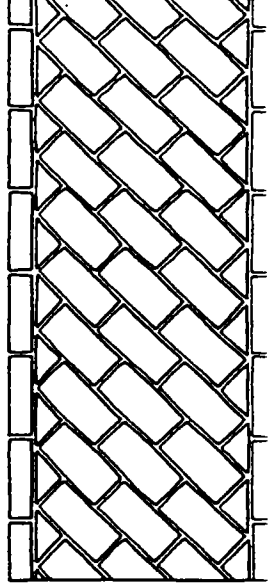

Rectangular

Stone

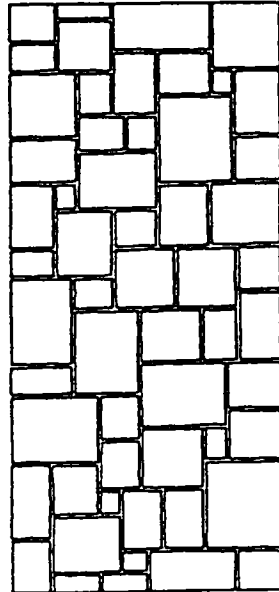

Random Rectangular

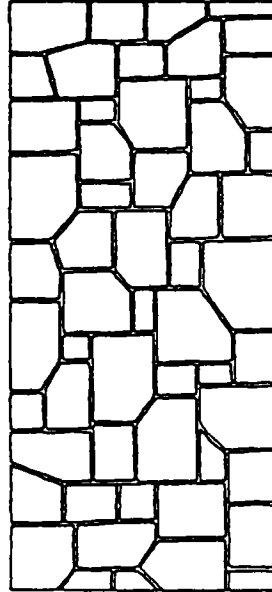

Semi-irregular

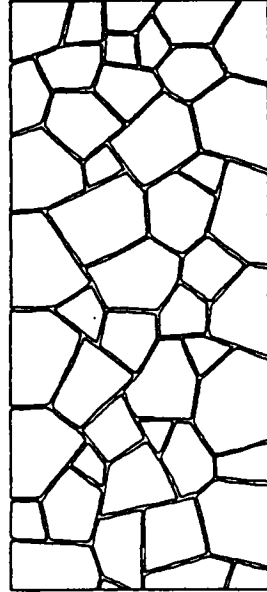

Irregular (fitted)

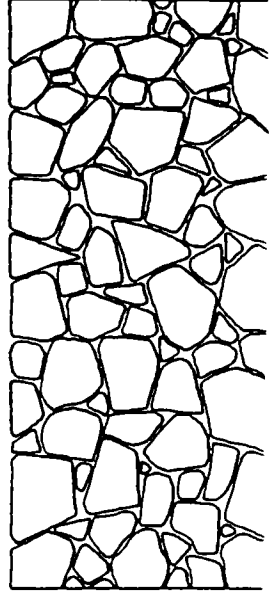

Crazy Paving (irregular unfitted)

Figure 9

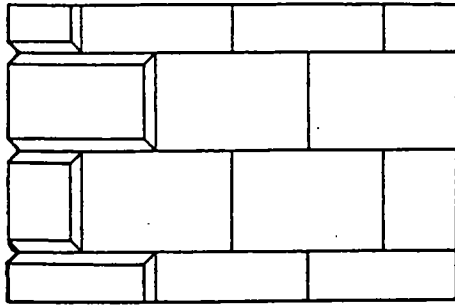

Ashlar with chamfered quoins

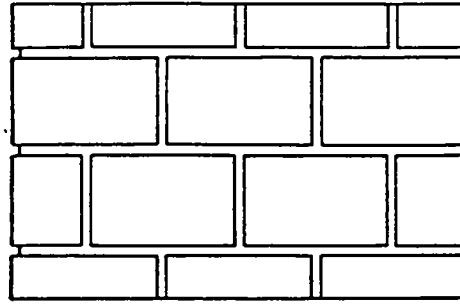

Rustication

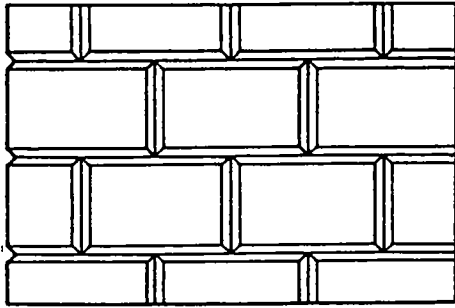

Chamfered Rustication

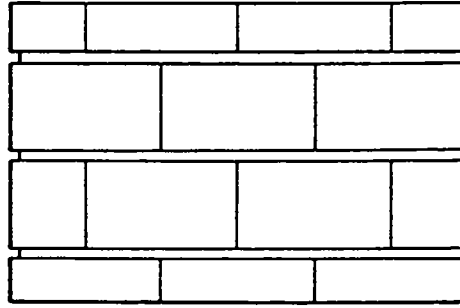

Banded Rustication

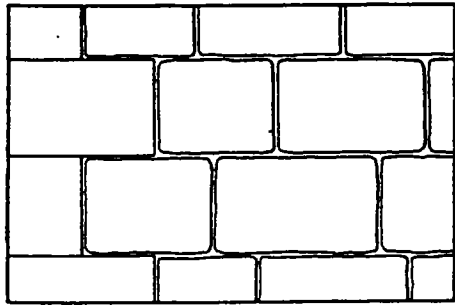

Dressed Stone

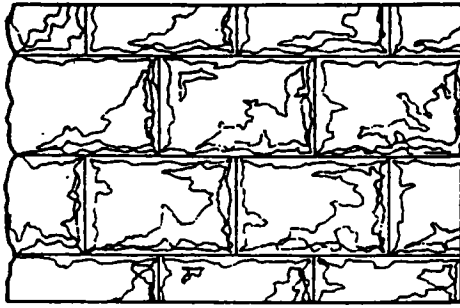

Cyclopean (rock-faced) Stone

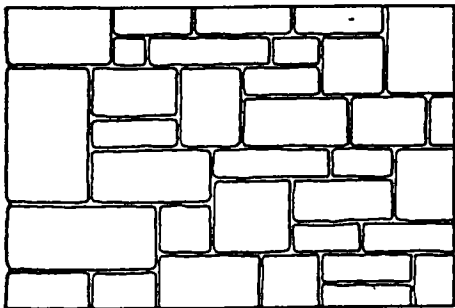

Snecked Stone

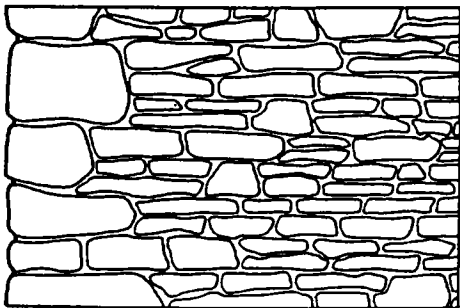

Random Rubble

Figure 10

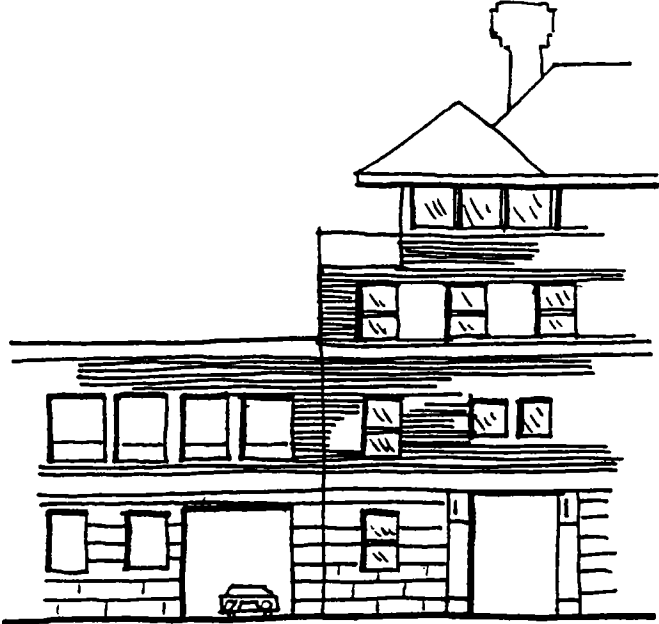

Parking structures can be integrated with residential or commercial building by using similar materials and similar proportions of openings and by extending horizontal elements (i.e. cornice).



The garage entry takes advantage of topography to be visually subordinate to the pedestrian entry.

Figure 11

L.A.K.E. O.S.W.E.G.O.
DEMONSTRATION STREET PROJECT

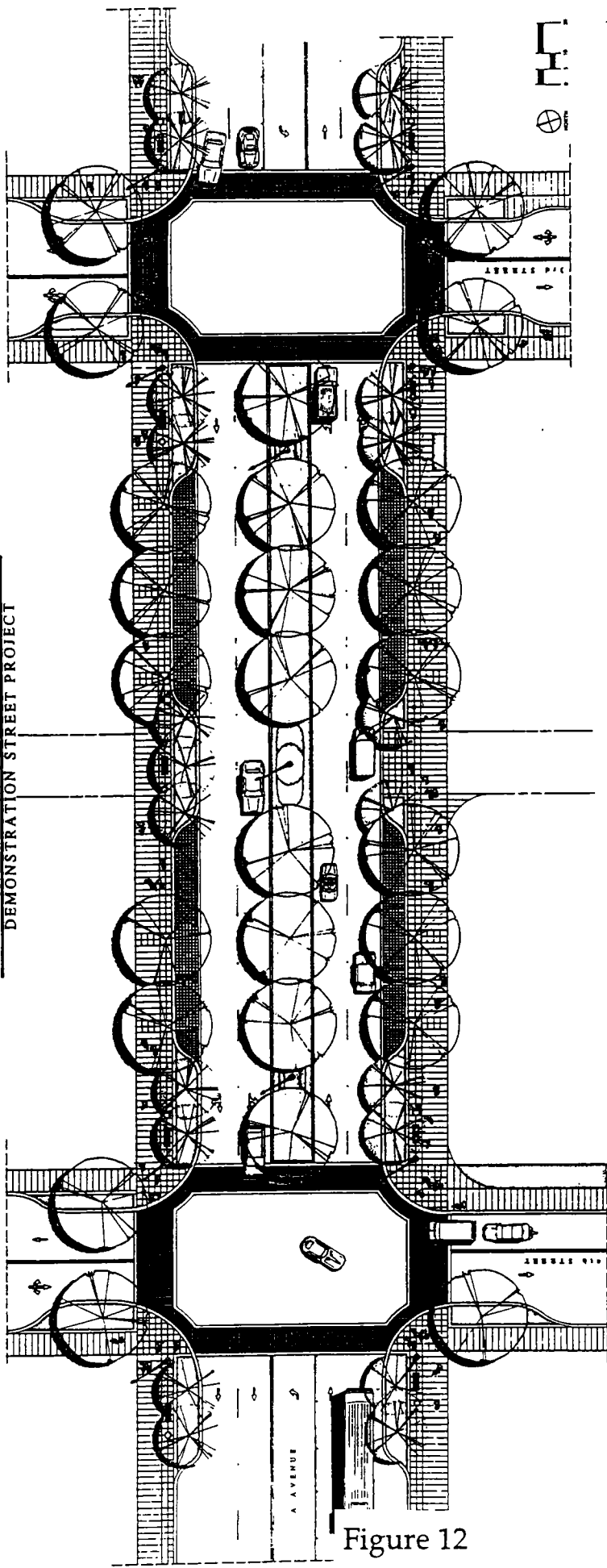

CENTURY WEST
ENGINEERS

MIKE ZAHN & ASSOCIATES
LANDSCAPE ARCHITECTS

DKS ASSOCIATES
TRAFFIC - TRANSPORTATION

FLETCHER FARR AYOTTE
ARCHITECTS

Figure 12

APPENDIX 50.66
OLD TOWN NEIGHBORHOOD
DESIGN STANDARDS

OLD TOWN STYLES DESCRIPTION

Old Town Style:

Building appearance which borrows from the vernacular, (gable front) style, craftsman bungalow style and Cape Cod (neo-colonial) style. These buildings are characterized by simple massing and composition, use of natural materials, window and door openings emphasized with trim and gable and hip roof forms.

Vernacular Style:

One or two story with moderately pitched gable front or side shape, often with a partial or full width front porch with shed or hip roof. Vernacular house forms include square, rectangular, L- or T-plan with intersecting gables. These houses include symmetrical placement of doors and double hung sash windows, which are emphasized by window trim. They are typically sided with shiplap, clapboard or other wood horizontal siding. Typically, there is little or no decorative detailing. On the more complex structures with intersecting gables, the roof ridge of one of the gables is sometimes higher than the other adjacent wing.



A typical vernacular "worker cottage" in Old Town

Craftsman Style:

Low pitched gabled roof (occasionally hip) with wide, overhanging eaves, roof rafters usually exposed, decorative (false) beams or braces commonly added under gables, porches either full or partial width, with roof supported by tapered square columns or pedestals, frequently extended to ground level and frequently composed of stone, clapboard, brick or in combination. Dormers are commonly gabled, hip or shed roofed. Double hung windows, often multi-light in top half or often grouped in two's or three's, or large windows the front facade with smaller pane sections above and often flanked by two smaller windows. The most common wall cladding is wood clapboard, wood and shingles, with stone and brick used in combination, or for porch post pillars or columns. Stucco is occasionally used as is board and batten.

*Craftsman*

Neo-Colonial (or Cape Code):

This is one of the styles built in America since 1940. The neo-colonial is a simplified form loosely based on the previously popular colonial of the 20's and 30's. This style grades into preceding Colonial Revival style but differs in showing less concern for precisely copying Colonial prototypes. Free interpretations of colonial door surrounds and colonnaded entry porches are often used. Facades, although usually symmetrical, also lack the regularly spaced patterns of window placement seen in Georgian and Adam houses.

Cape Cod structures have a rectangular or 1-plan, side gable roofs, sometimes with an intersecting gable often with dormers. There is often an accentuated front door, with a decorative crown (pediment) supported by pilasters or extended forward and supported by slender columns to form a small entry porch. Windows typically are with double-hung sashes, usually with multi-pane glazing on one or both sashes, frequently in adjacent pairs.

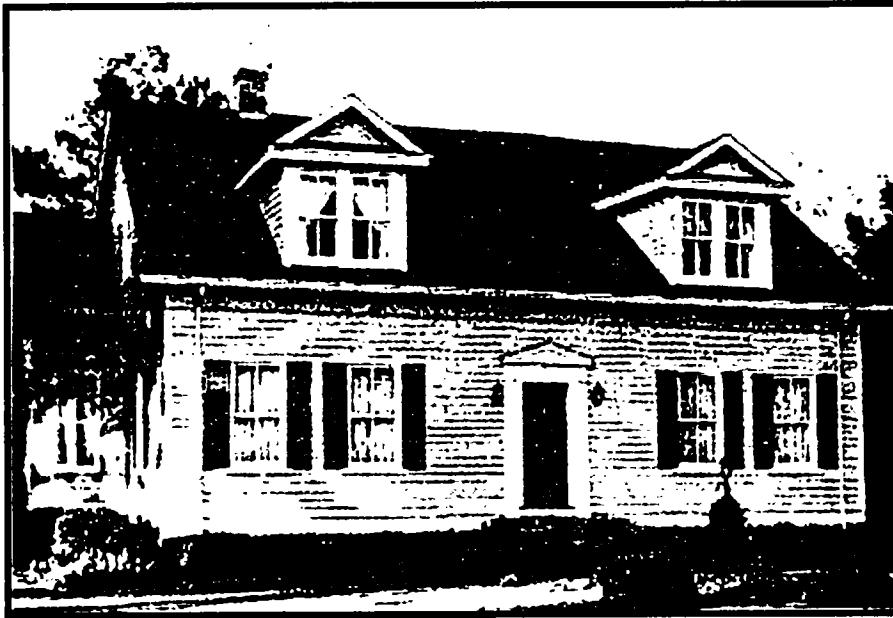

Cape Cod

Figure 1

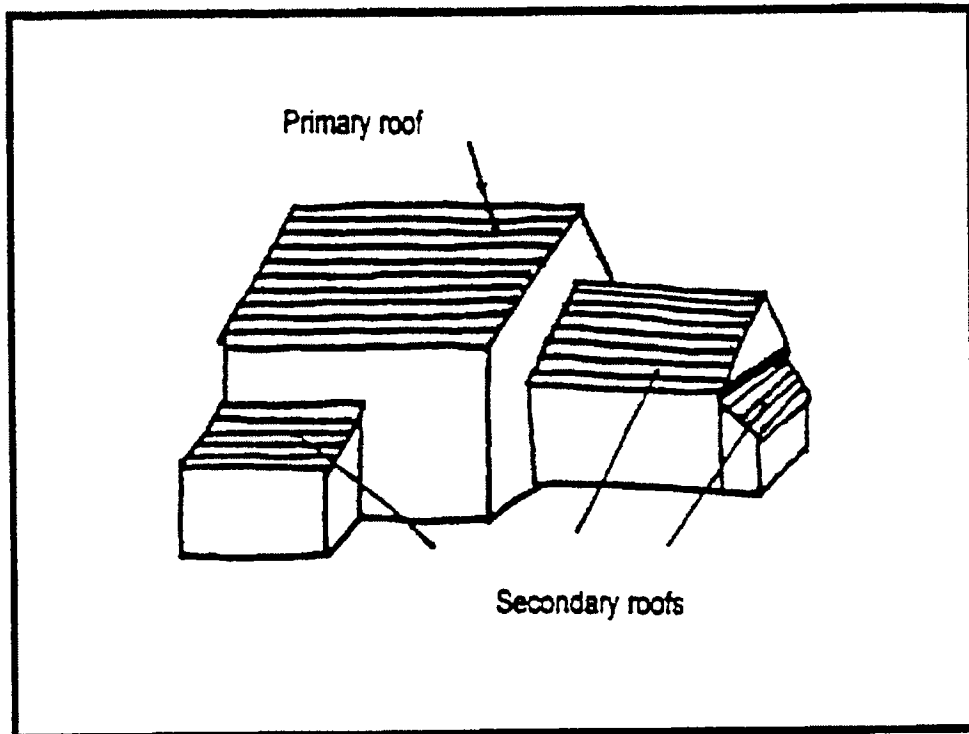

Primary and Secondary Roof Forms

Figure 2

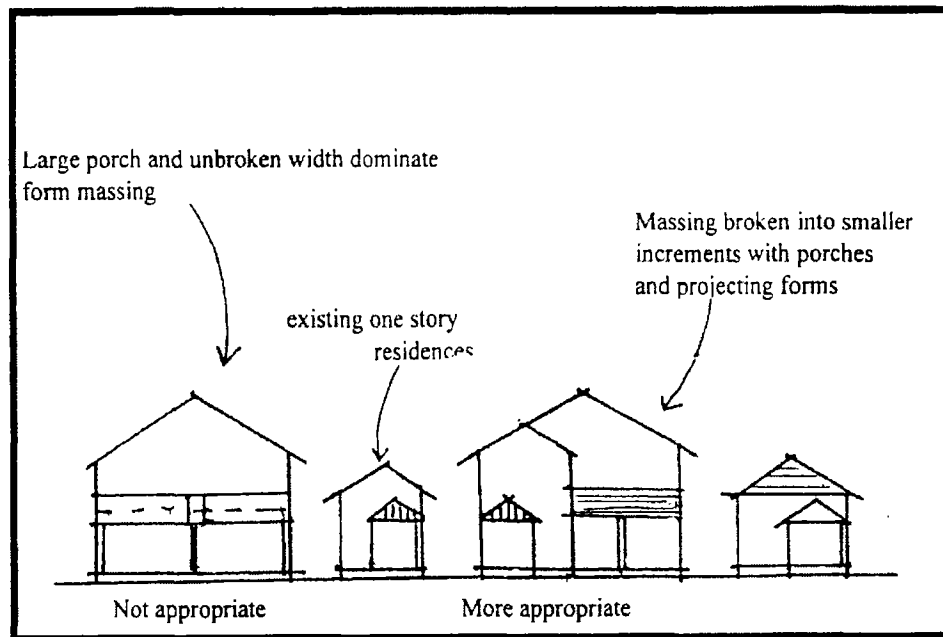

- Create visual linkages
- Offset building walls and roof lines
- Incorporate similar roof forms and smaller design elements

(Note: The intent of this drawing is not to indicate that full-length porches are not acceptable for multi-family dwellings, but that design features must be considered along with overall form and massing to achieve compatibility.)

50.66-A
Figure 3

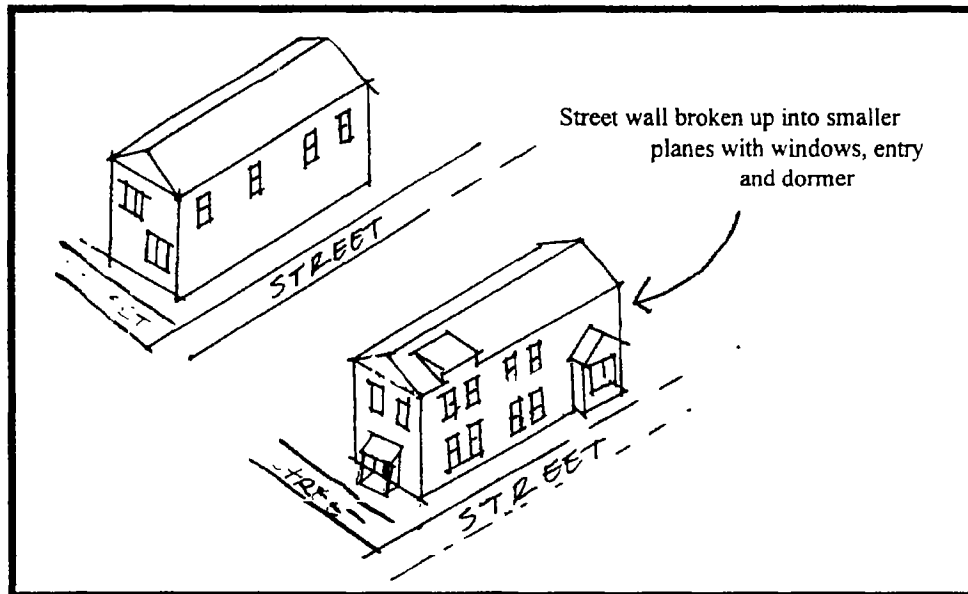

- Create visual interest along the street
- Incorporate porches, dormers and bays to reduce scale of buildings and better relate to existing structures

50.66-A
Figure 4

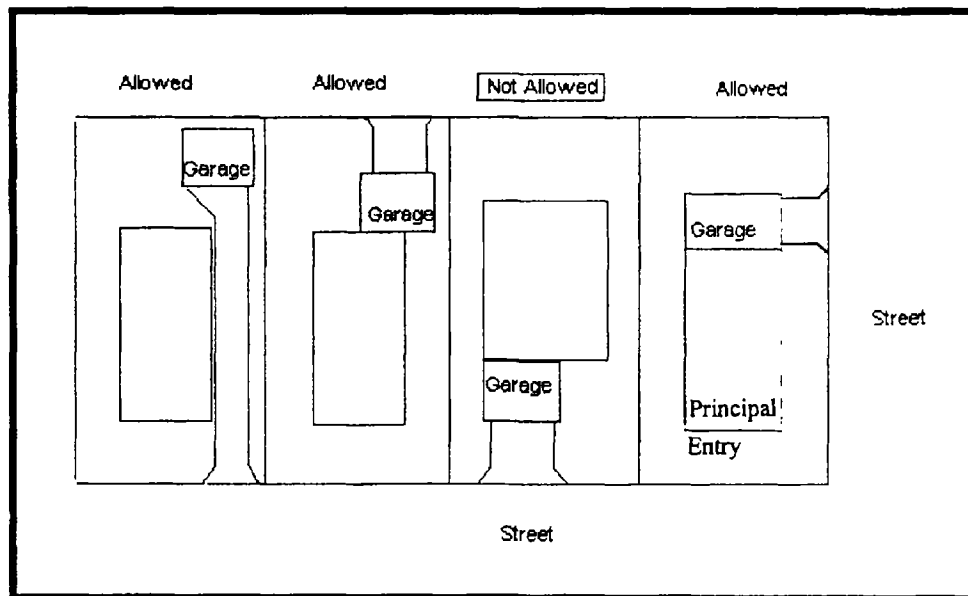

Old Town Design Standards
CITY OF LAKE OSWEGO
APPROVED STREET TREE PLANTING LIST

TREES FOR PLANTING STRIP SIZE UP TO 4'

<i>Tree Species</i>	<i>Height</i>	<i>Spread</i>	<i>Structure</i>	<i>Foliage</i>	<i>Flowers</i>	<i>Fall Color</i>	<i>Fruit</i>
Crimson Sentry Norway Maple / <i>Acer platanoides</i> 'Crimson Sentry'	25'	12'	Very Upright Dense	Red		Maroon to Reddish - Bronze	
Allegheny Serviceberry / <i>Amelanchier laevis</i>	25'	15'	Upright Oval	Green	White Clusters	Orange	Purplis Blue
Pyramidal Serviceberry / <i>Amelanchier canadensis</i> <i>Pyramidalis</i>	30'	12'	Very Upright	Dark Green	White Racemes	Brilliant Reds & Oranges	Maroo Purple Heavy Fruits
Lavalle Hawthorn / <i>Crataegus</i> X <i>Lavellei</i>	30'	20'	Upright to Vase	Dark Green	White Clusters	Bronze	Orange to Red
Crimson Cloud Hawthorn / <i>Crataegus laevigata</i> 'Crimson Cloud'	25'	18'	Oval	Glossy Green	Bright Red White Centers		Bright Red
Columnar Hawthorn / <i>Crataegus monogyna stricta</i>	30'	10'	Tightly Upright	Green	Double White	Yellow	Red
Flowering Ash / <i>Fraxinus ornus</i>	30'	15'	Pyramidal to Round	Medium Green	Off White Heavily Scented	Yellow	
Columnar Goldenrain / <i>Koelreuteria paniculata</i> <i>Fastigiata</i>	30'	6'	Narrow Fastigiata	Green	Yellow	Yellow	Yellow Pods
Goldenchain / <i>Laburnum Vossi</i>	30'	20'	Upright to Vase	Green	Yellow Racemes	Yellow	
Blireiana Plum / <i>Prunus</i> X <i>Blireiana</i>	20'	20'	Round	Purple - Green	Bright Pink	Reddish - Bronze	
Newport Plum / <i>Prunus cerasifera</i> 'Newport'	20'	20'	Oval to Round	Dark Purple	Light Pink	Reddish	
Japanese Tree Lilac / <i>Syringa reticulata</i>	25'	15'	Pyramidal	Green	White Panicle		Yellow Brown
Trident Maple / <i>Acer buergeranum</i>	25'	20'	Oval to Round	Dark Green		Yellow Orange	
Paperbark Maple / <i>Acer griseum</i>	30'	20'	Round	Green above & Silvery under		Bright Red - Orange	
Amur Maple / <i>Acer ginnala</i>	20'	20'	Upright Round	Green		Yellow	
Hedge Maple / <i>Acer campestre</i>	25'	25'	Round	Dark Green		Yellow	
Glorybower Tree / <i>Clerodendrum trichotomum</i>	20'	20'	Round	Dark Green	White Fragrant Clusters		Blue - Green
Rocky Mountain Glow Maple / <i>Acer grandidentatum</i> 'Schmidt'	25'	15'	Oval	Dark Green		Bright Red	

CITY OF LAKE OSWEGO
APPROVED STREET TREE PLANTING LIST

TREES FOR PLANTING STRIP SIZE 4' TO 5 1/2'

<i>Tree Species</i>	<i>Height</i>	<i>Spread</i>	<i>Structure</i>	<i>Foliage</i>	<i>Flowers</i>	<i>Fall Color</i>	<i>Fruit</i>
Queen Elizabeth Maple / Acer campestre 'Queen Elizabeth'	35'	30'	Upright	Dark Green		Yellow	
Cleveland II Norway Maple / Acer platanoides 'Cleveland'	40'	25'	Upright	Medium Green		Bright Yellow	
Parkway Norway Maple / Acer platanoides 'Columnar Broad'	40'	25'	Oval	Dark Green		Yellow	
Paperbark Maple / Acer griseum	30'	20'	Round	Green above & Silver under		Bright Red - Orange	
Variegated Norway Maple / Acer platanoides 'Drummondii'	35'	25'	Broadly Oval	Light Green White Margin			
Pacific Sunset Maple / Acer truncatum X A. Platanoides 'Warrenred'	30'	25'	Upright	Dark Green			
Chinese Dogwood / Cornus kousa Chinensis	30'	30'	Round	Green	White	Red	Red Pi
September Goldenrain / Koelreuteria paniculata 'September'	30'	25'	Flat Topped Open	Green	Yellow	Yellow	
Red Bud / Cercis canadensis	20'	25'	Spreading	Medium Green	Pink	Yellow	
American Hophornbeam / Ostrya virginiana	35'	25'	Oval	Medium Green		Yellow	
Newport Plum / Prunus cerasifera 'Newport'	20'	20'	Oval to Round	Dark Purple	Light Pink		Red
Capital Pear / Pyrus calleryana 'Capital'	35'	12'	Columnar	Medium Green	White Clusters	Reddish Purple	
Chanticleer Pear / Pyrus calleryana 'Glen's Form'	40'	15'	Pyramidal	Glossy Green	White Clusters	Orange Red	
Rocky Mountain Glow Maple / Acer grandidentatum 'Schmidt'	25'	15'	Oval	Dark Green		Bright Red	
Japanese Stewartia / Stewartia pseudo-camellia	40'	20'	Pyramidal	Dark Green	White Orange Center	Dark Red	
Rancho Linden / Tilia cordata 'Rancho'	45'	20'	Pyramidal	Dark Green	Yellow Fragrant	Yellow	
Chancellor Linden / Tilia cordata 'Chancellor'	35'	20'	Pyramidal	Dark Green		Yellow	

CITY OF LAKE OSWEGO
APPROVED STREET TREE PLANTING LIST

TREES FOR PLANTING STRIP SIZE 4' TO 5 1/2'

<i>Tree Species</i>	<i>Height</i>	<i>Spread</i>	<i>Structure</i>	<i>Foliage</i>	<i>Flowers</i>	<i>Fall Color</i>	<i>Fruit</i>
Lavalle Hawthorn / <i>Crataegus X Lavellei</i>	30'	20'	Upright	Dark Green	White	Bronze Red	Red
Flowering Ash / <i>Fraxinus ornus</i>	30'	15'	Pyramidal to Round	Medium Green	Off White Fragrant	Yellow	
Pyramidal Hornbeam / <i>Carpinus betulus fastigiata</i>	35'	20'	Broadly Oval	Dark Green		Yellow	
Olmsted Columnar Norway Maple / <i>Acer platanoides columnar 'Olmsted'</i>	40'	20'	Upright	Dark Green		Yellow	
Armstrong II Red Maple <i>Acer rubrum 'Armstrong'</i>	45'	15'	Narrow Fastigiata	Light Green		Yellow Orange - Red	
Gerling Red Maple <i>Acer rubrum 'Gerling'</i>	35'	20'	Pyramidal	Green		Orange - Red	
Saratoga Ginkgo <i>Ginkgo biloba 'Saratoga'</i>	30'	30'	Compact Spreader	Greenish - Gold		Yellow	
Columnar Sargent Cherry <i>Prunus sargentii columnaris</i>	30'	10'	Fastigiata	Green	Deep Pink	Orange - Red	
Glorybower Tree <i>Clerodendrum trichotomum</i>	20'	20'	Round	Dark Green	White Fragrant Clusters		Blue - Green
Globe Sugar Maple / <i>Acer saccharum globosum</i>	15'	20'	Round	Medium Green		Yellow & Orange	
Globe Serviceberry / <i>Amelanchier canadensis oblongifolia</i>	20'	20'	Round	Green	White	Bright Yellow - Red	Maroo Purple
Magnolia soulangiana <i>Saucer magnolia</i>	20'	20'	Upright-Rounded	Green	Red/White	Yellow-Brown	

**CITY OF LAKE OSWEGO
APPROVED STREET TREE PLANTING LIST**

TREES FOR PLANTING STRIP SIZE 6' TO 8'

<i>Tree Species</i>	<i>Height</i>	<i>Spread</i>	<i>Structure</i>	<i>Foliage</i>	<i>Flowers</i>	<i>Fall Color</i>	<i>Fruit</i>
Urbanite Ash / <i>Fraxinus pennsylvanica</i> 'Urbanite'	50'	40'	Broadly Pyramidal	Lustrous Green		Bronze	
Marshall Ash / <i>Fraxinus pennsylvanica lanceolata</i>	50'	40'	Broadly Oval	Dark Green		Yellow	
Skyline Ash / <i>Fraxinus americana</i> 'Skyline'	45'	35'	Oval	Medium Green		Orange Red	
European Hornbeam / <i>Carpinus betulus</i>	50'	35'	Oval to Round	Dark Green		Gold Yellow	
Hackberry / <i>Celtis occidentalis</i>	45'	35'	Oval	Dark Green		Yellow	
Katsura Tree / <i>Cercidiphyllum japonicum</i>	40'	35'	Oval	Bluish - Green		Yellow to Scarlet	
Sourwood / <i>Oxydendrum arboreum</i>	50'	25'	Pyramidal	Green	White	Brilliant Scarlet	Golden
Macho Cork Tree / <i>Phellodendron amurense</i> 'Macho'	40'	30'	Broadly Vase	Medium Green		Yellow	
Tricolor Beech / <i>Fagus sylvatica</i> 'Rosed - Marginata'	40'	30'	Broadly Oval	Purple, Light Pink Border			
Yellowwood / <i>Claprasitis lutea</i>	40'	35'	Round	Yellow - Green to Bright - Green	White Fragrant Clusters	Orange to Yellow	
Skyline Honeylocust / <i>Gleditsia triacanthos</i> 'Skyline'	50'	35'	Broadly Pyramidal	Medium Green		Golden	
Shademaster Honeylocust / <i>Gleditsia triacanthos</i> 'Shademaster'	45'	35'	Vase	Dark Green		Yellow	
Scarlet Oak / <i>Quercus coccinea</i>	50'	40'	Broadly Oval	Glossy Green		Scarlet	
Glenleven Linden / <i>Tilia cordata</i> 'Glenleven'	45'	30'	Pyramidal	Medium Green		Yellow	
Halka Zelkova / <i>Zelkova serrata</i> 'Halka'	45'	30'	Vase	Medium Green		Yellow	
Globe Norway Maple / <i>Acer platanoides globosum</i>	15'	18'	Round	Medium Green		Yellow	
Globe Sugar Maple / <i>Acer saccharum globosum</i>	15'	20'	Round	Medium Green		Yellow & Oranges	
Saratoga Ginkgo / <i>Ginkgo biloba</i> 'Saratoga'	30'	30'	Round	Green Gold		Yellow	
Emerald Queen Norway Maple / <i>Acer platanoides</i> 'Emerald Queen'	50'	40'	Oval	Dark Green		Bright Yellow	

CITY OF LAKE OSWEGO
APPROVED STREET TREE PLANTING LIST

TREES FOR PLANTING STRIP SIZE 6' TO 8'

<i>Tree Species</i>	<i>Height</i>	<i>Spread</i>	<i>Structure</i>	<i>Foliage</i>	<i>Flowers</i>	<i>Fall Color</i>	<i>Fruit</i>
Crimson King Norway Maple / <i>Acer platanoides</i> 'Crimson King'	40'	35'	Round	Deep Purple		Reddish Orange	
Superform Maple / <i>Acer platanoides</i> 'Superform'	45'	40'	Oval	Medium Green		Yellow	
Red Sunset Red Maple / <i>Acer rubrum</i> 'Franksred'	45'	35'	Oval	Dark Green		Orange Red	
October Glory Maple / <i>Acer rubrum</i> 'October Glory'	40'	35'	Broadly Oval	Medium Green		Red to Purple	
Embers Red Maple / <i>Acer rubrum</i> 'Embers'	50'	40'	Open	Green		Bright Red	
Magnolia soulangiana Saucer magnolia	20'	20'	Upright-Rounded	Green	Red/White	Yellow-Brown	
* Douglas-fir, <i>Pseudotsuga menziesii</i>	100'			Dark green		evergreen	
Lodgepole Pine, <i>Pinus contorta</i>	100'			Dark green			
Shore pine, <i>Pinus contorta</i> var. <i>contorta</i>	25'		Upright-Irregular	Dark green		evergreen	
* Western red cedar, <i>Thuja plicata</i>	100'+		Pyramidal			evergreen	
* Grand fir, <i>Abies grandis</i>	100'+			Dark green		evergreen	
Noble fir, <i>Abies procera</i>	90'			Bluish green		evergreen	
Sitka spruce, <i>Picea sitchensis</i>						evergreen	
* Western hemlock, <i>Tsuga heterophylla</i>	100'		Narrow-pyramidal			evergreen	
Incense cedar, <i>Libocedrus decurrens</i>	90'		Narrow-pyramidal	Dark green		evergreen	

CITY OF LAKE OSWEGO

APPROVED STREET TREE PLANTING LIST

TREES FOR PLANTING STRIP SIZE 8 1/2' AND LARGER

<i>Tree Species</i>	<i>Height</i>	<i>Spread</i>	<i>Structure</i>	<i>Foliage</i>	<i>Flowers</i>	<i>Fall Color</i>	<i>Fruit</i>
Sycamore Maple / <i>Acer Pseudo platanus</i>	60'	50'	Wide Spreading	Green		Yellow	
Schwedler Norway Maple / <i>Acer platanoides</i> 'Schwedler'	50'	45'	Round	Green		Yellow	
Red Maple / <i>Acer rubrum</i>	60'	50'	Oval	Medium Green		Orange Red	
Red Oak / <i>Quercus borealis rubra</i>	65'	50'	Round	Green		Red	
Moraine Sweetgum / <i>Liquidambar styraciflua</i> 'Moraine'	60'	30'	Oval	Dark Green		Red Purple	
Red Horsechestnut / <i>Aesculus X Carnea</i> 'Briothii'	60'	40'	Round	Dark Green	Red	Yellow	
Wineleaf Sycamore Maple / <i>Acer pseudo platanus</i> 'Spaethi'	60'	50'	Pyramidal	Dark Green			
Urbanite Ash / <i>Fraxinus pennsylvanica</i> 'Urbanite'	50'	40'	Broadly Pyramidal	Lustrous Green		Bronze	
Yellowwood / <i>Cladrastis lutra</i>	40'	35'	Round	Yellow - Green to Bright - Green	White Fragrant Clusters	Orange to Yellow	
Scarlet Oak / <i>Quercus coccinea</i>	50'	40'	Broadly Oval	Glossy Green		Scarlet	
Halka Zelkova / <i>Zelkova serrata</i> 'Halka'	45'	30'	Vase	Medium Green		Yellow	
Saratoga Ginkgo / <i>Ginkgo biloba</i> 'Saratoga'	50' - 80'	40' - 80'	Variable	Green Gold		Yellow	
Halka Honeylocust / <i>Gleditsia triacanthos</i> 'Christie'	55'	40'	Upright	Green		Yellow	
Flame Ash / <i>Fraxinus oxycarpa</i> 'Flame'	35'	30'	Round	Green		Purple to Red	
Summit Ash / <i>Fraxinus pennsylvanica lanceolata</i>	45'	25'	Pyramidal	Medium Green		Yellow	
Purple Rivers Beech / <i>Fagus sylvatica</i> 'Riversi'	60'	40'	Oval	Deep Purple		Bronze	
Tricolor Beech / <i>Fagus sylvatica</i> 'Rosed - Marginata'	40'	30'	Broadly Oval	Purple, Light Pink Borders		Bronze	

**CITY OF LAKE OSWEGO
APPROVED STREET TREE PLANTING LIST**

TREES FOR PLANTING STRIP SIZE 8 1/2' AND LARGER

<i>Tree Species</i>	<i>Height</i>	<i>Spread</i>	<i>Structure</i>	<i>Foliage</i>	<i>Flowers</i>	<i>Fall Color</i>	<i>Fruit</i>
Catalpa / <i>Catalpa speciosa</i>	75'	50'	Round	Green	White	Yellow	
Katsura Tree / <i>Cercidiphyllum japonicum</i>	40'	35'	Oval	Bluish - Green		Yellow to Scarlet	
Sourwood / <i>Oxydendrum arboreum</i>	50'	25'	Pyramidal	Green	White	Brilliant Scarlet	Golden

APPENDIX 50.67
WEST LAKE GROVE DESIGN DISTRICT
STANDARDS

APPENDIX 50.67 - A

West Lake Grove Design District Standards

Figure No.	Title
1	West Lake Grove Design District
2(a)	Auto Transportation and Circulation
2(b)	Internal Parking and Circulation Plan
2(c)	Pedestrian Facilities and Pathways
3(a)	Street Sections – West Sunset Street (Section A-A)
3(b)	Street Sections – West Sunset Street (Section B-B)
3(c)	Street Sections – Lower Boones Ferry Road (Section C-C)
3(d)	Walkway (Section D-D)
3(e)	Street Sections - Lower Boones Ferry Road (Section E-E)
4	Building Massing
5	Building Window Openings and Blank Walls
6	Building Rain Protection
7	Required Street Lighting

WEST LAKE
GROVE
DESIGN
DISTRICT

Appendix 50.67-A
Figure 1
October, 1998

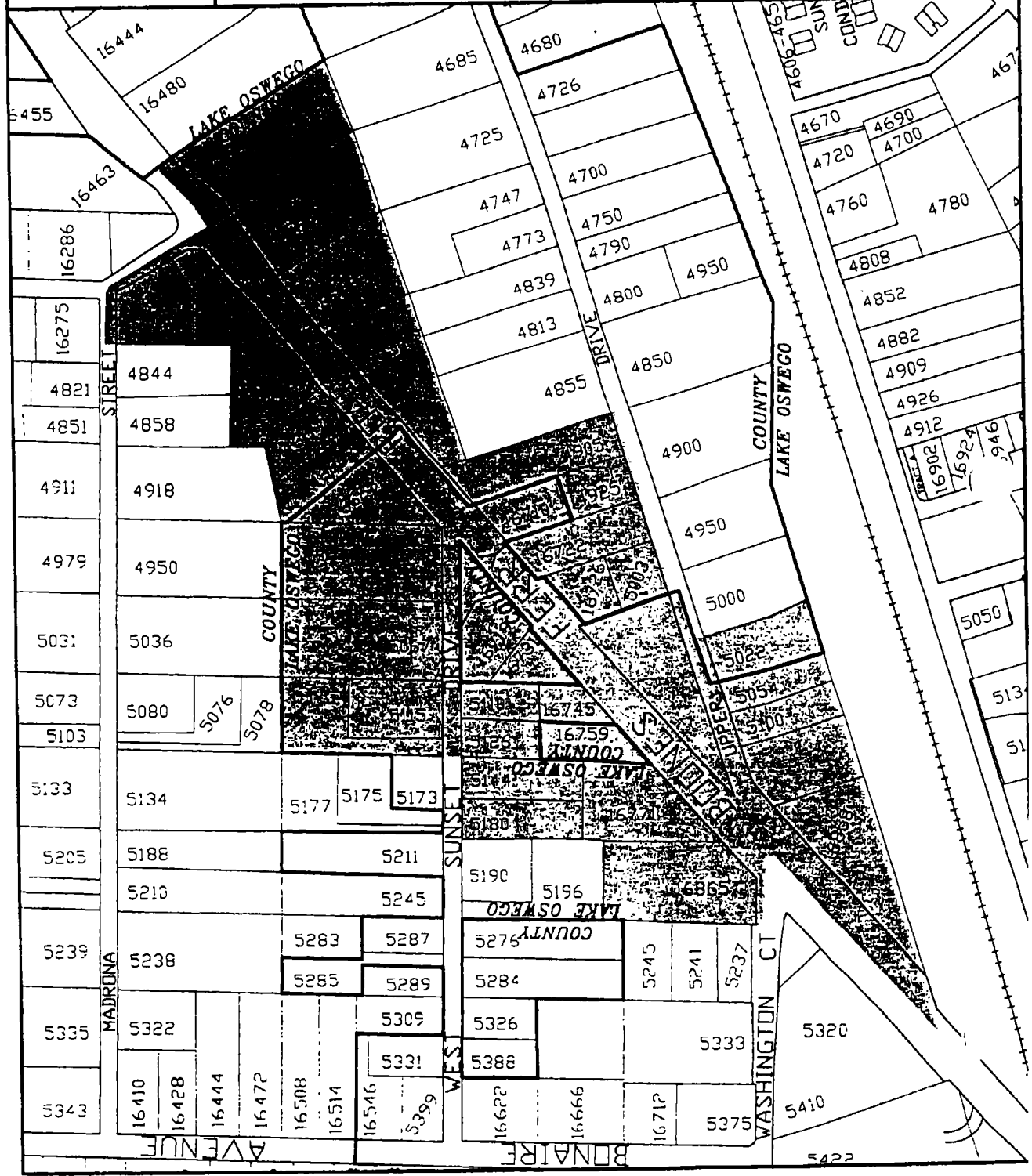

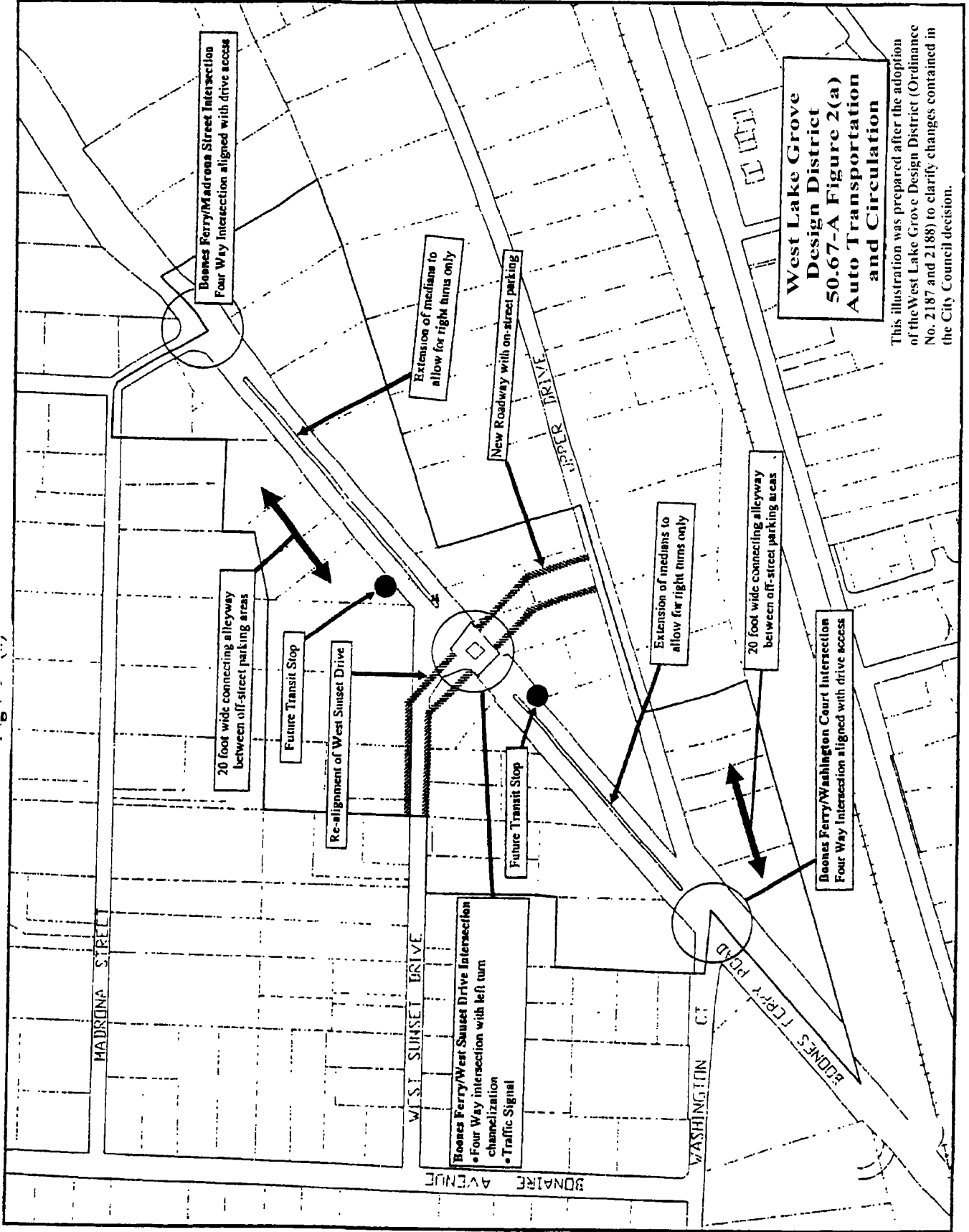

Figure 2 (b)

INTERNAL PARKING & CIRCULATION PLAN

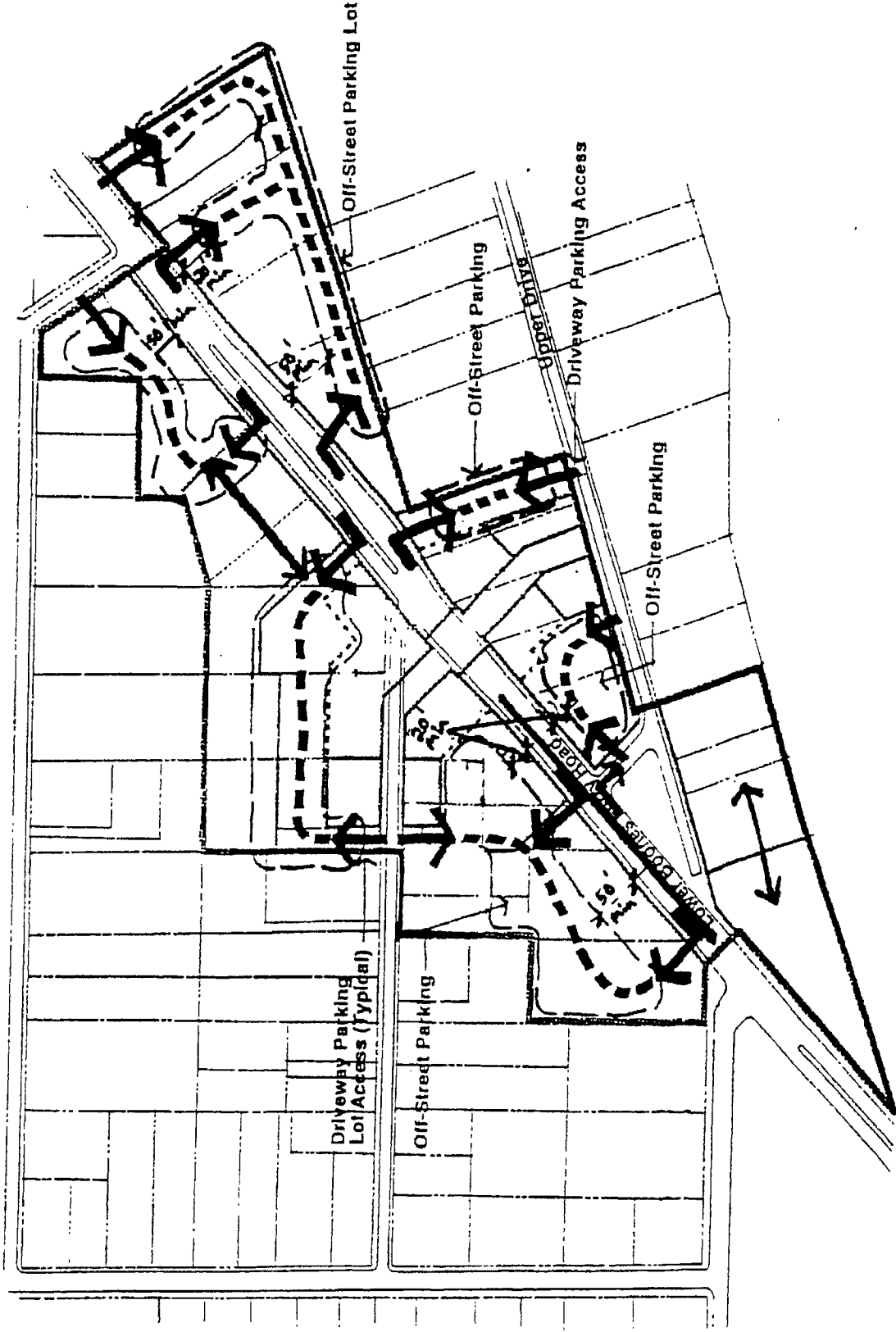
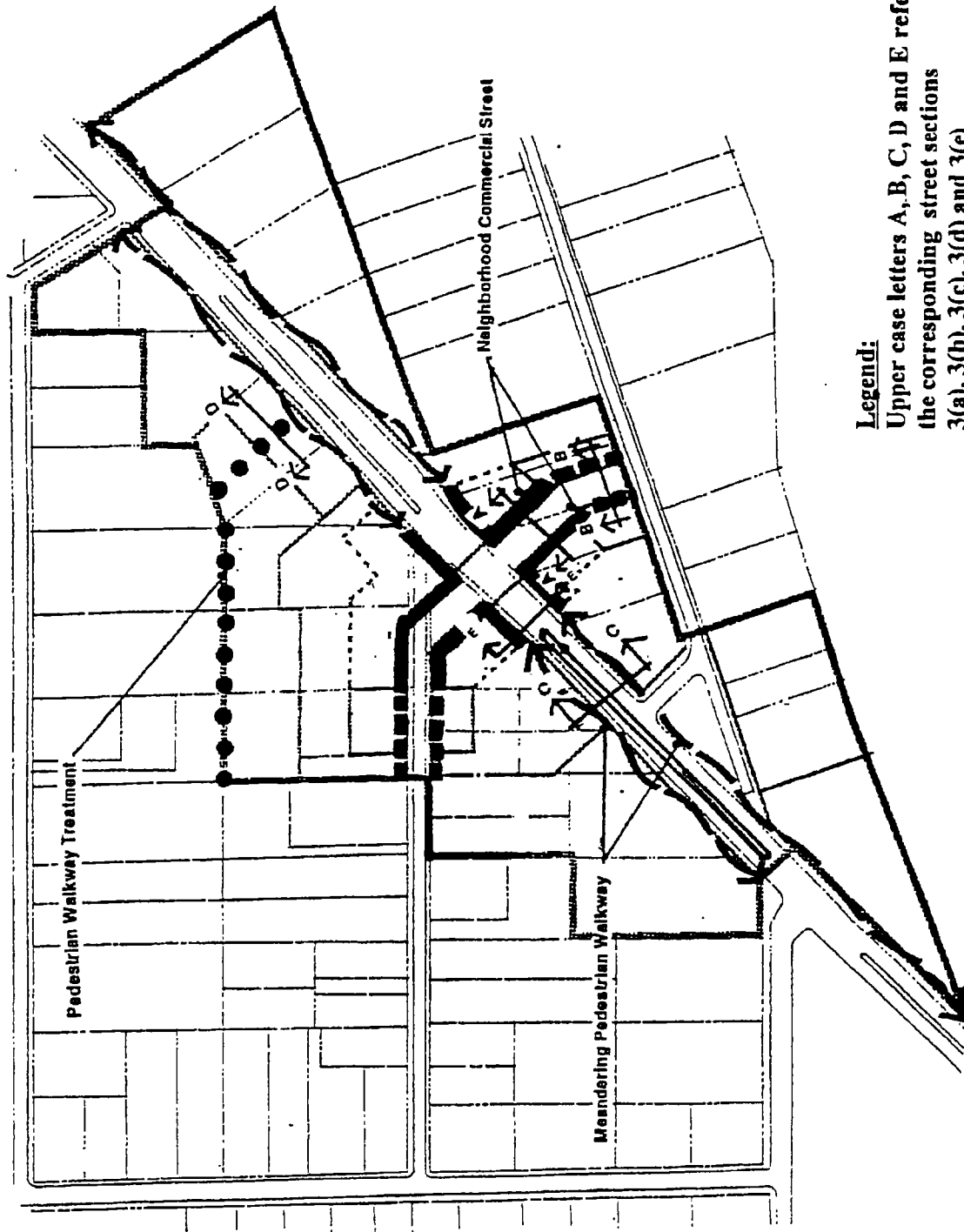

Figure 2 (c)

Pedestrian Facilities and Pathways



Legend:
Upper case letters A, B, C, D and E refer to the corresponding street sections 3(a), 3(b), 3(c), 3(d) and 3(e)

Figure 3 (a)

STREET SECTIONS

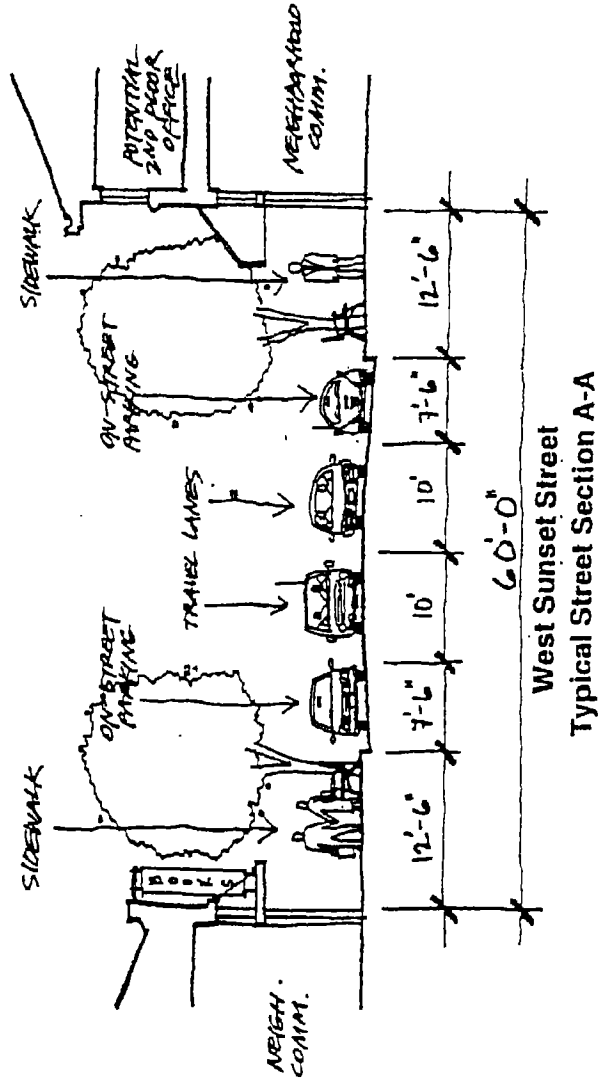

Figure 3 (b)

STREET SECTIONS

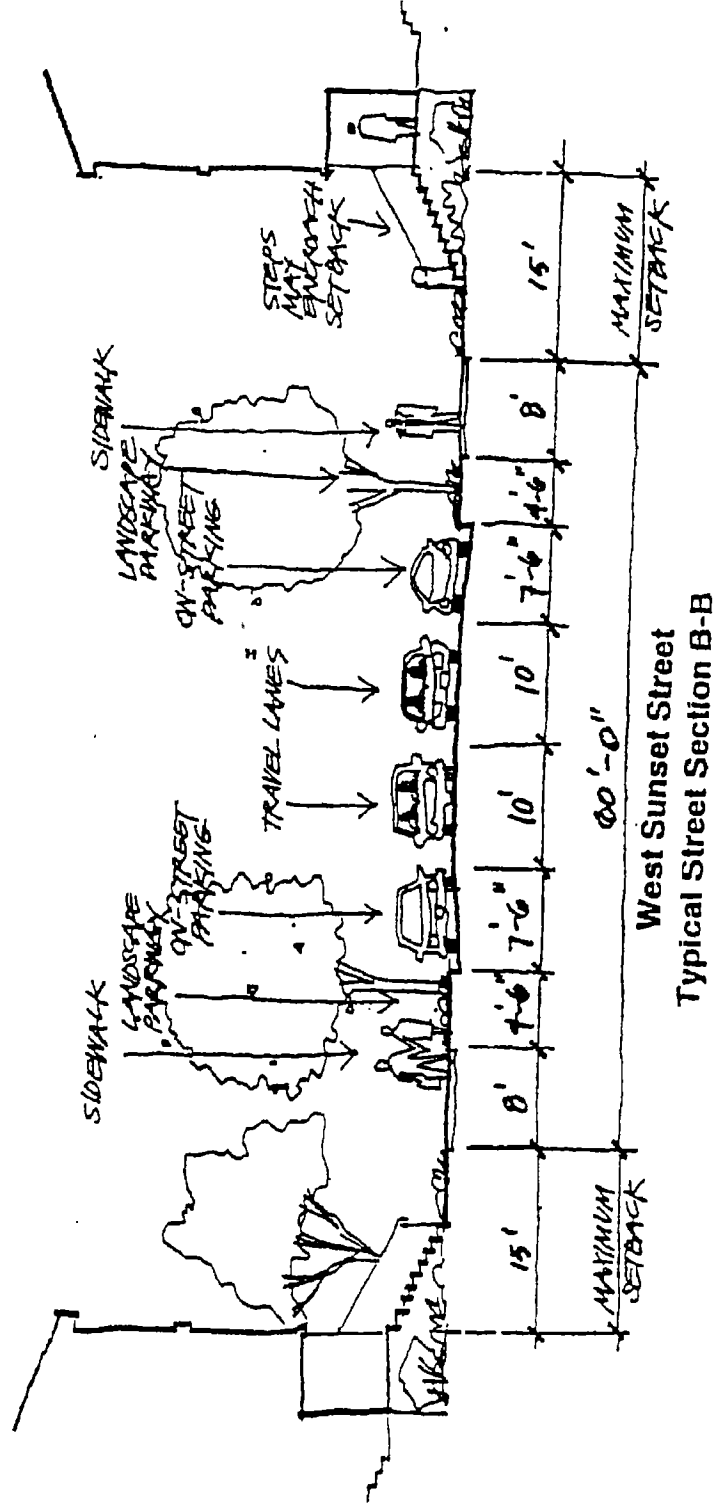
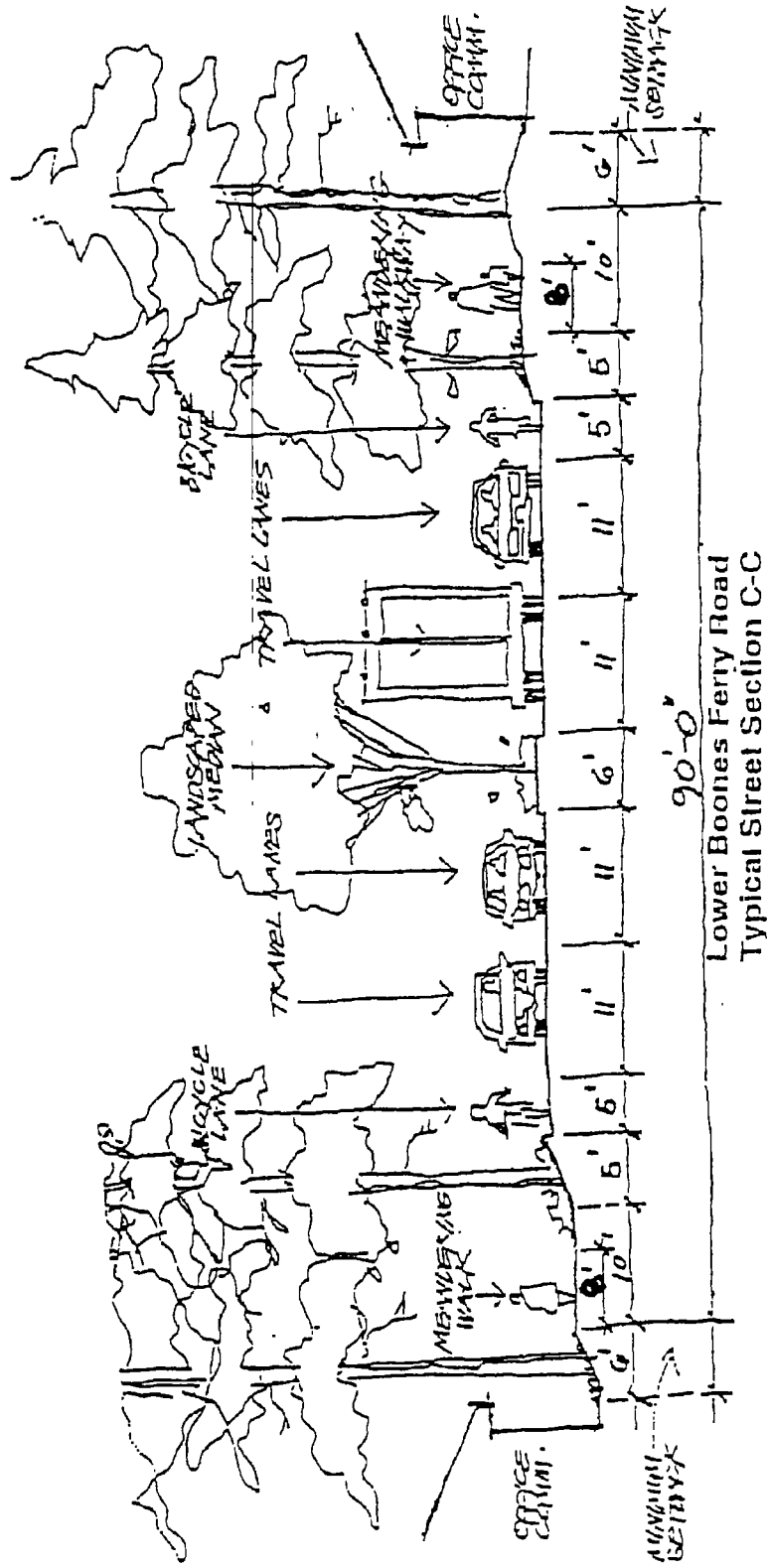

Figure 3 (c)

West Lake Grove Design District
Lake Oswego, Oregon

10-Minute Response

STREET SECTIONS



9/01

Crandall Arambula PC

Figure 3 (d)

WALKWAY SECTION

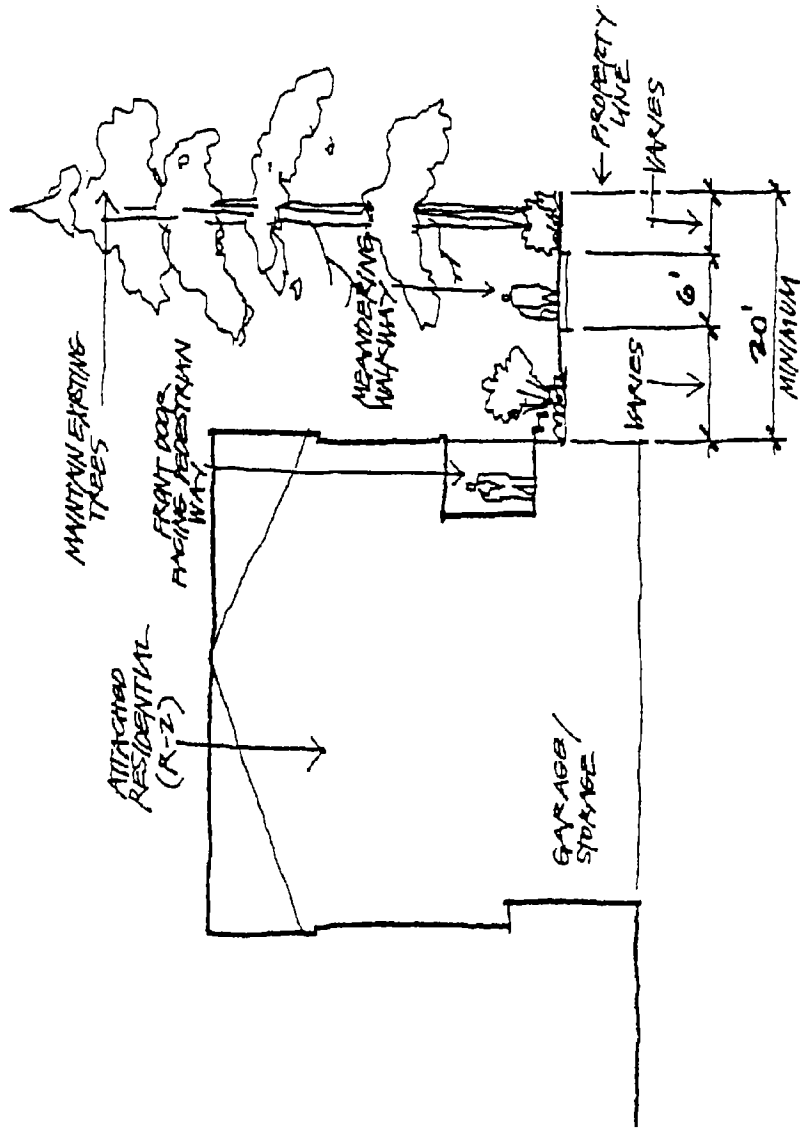

Typical Walkway Section D-D

Figure 3 (e)

TGM Quick Response

West Lake Grove Design District
Lake Oswego, Oregon

STREET SECTIONS

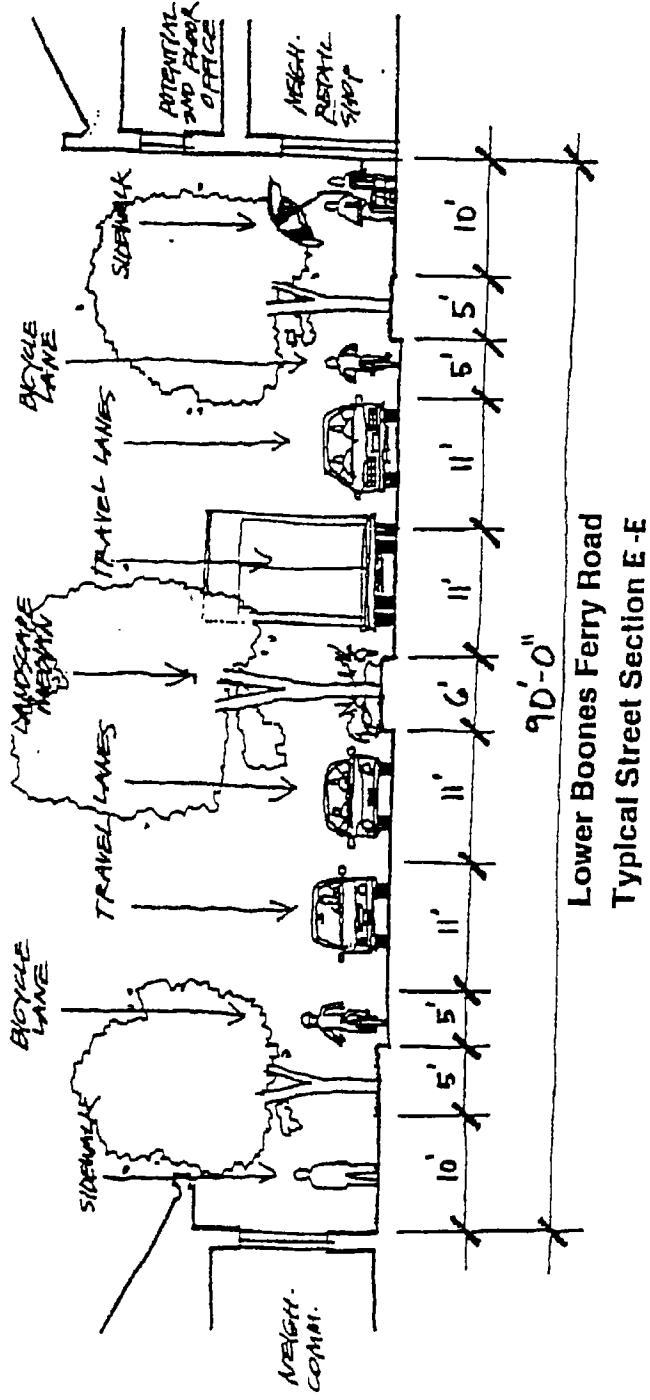

Lower Boones Ferry Road
Typical Street Section E-E

CRANDALL ARAMBULA PC

BUILDING MASSING

Figure 4

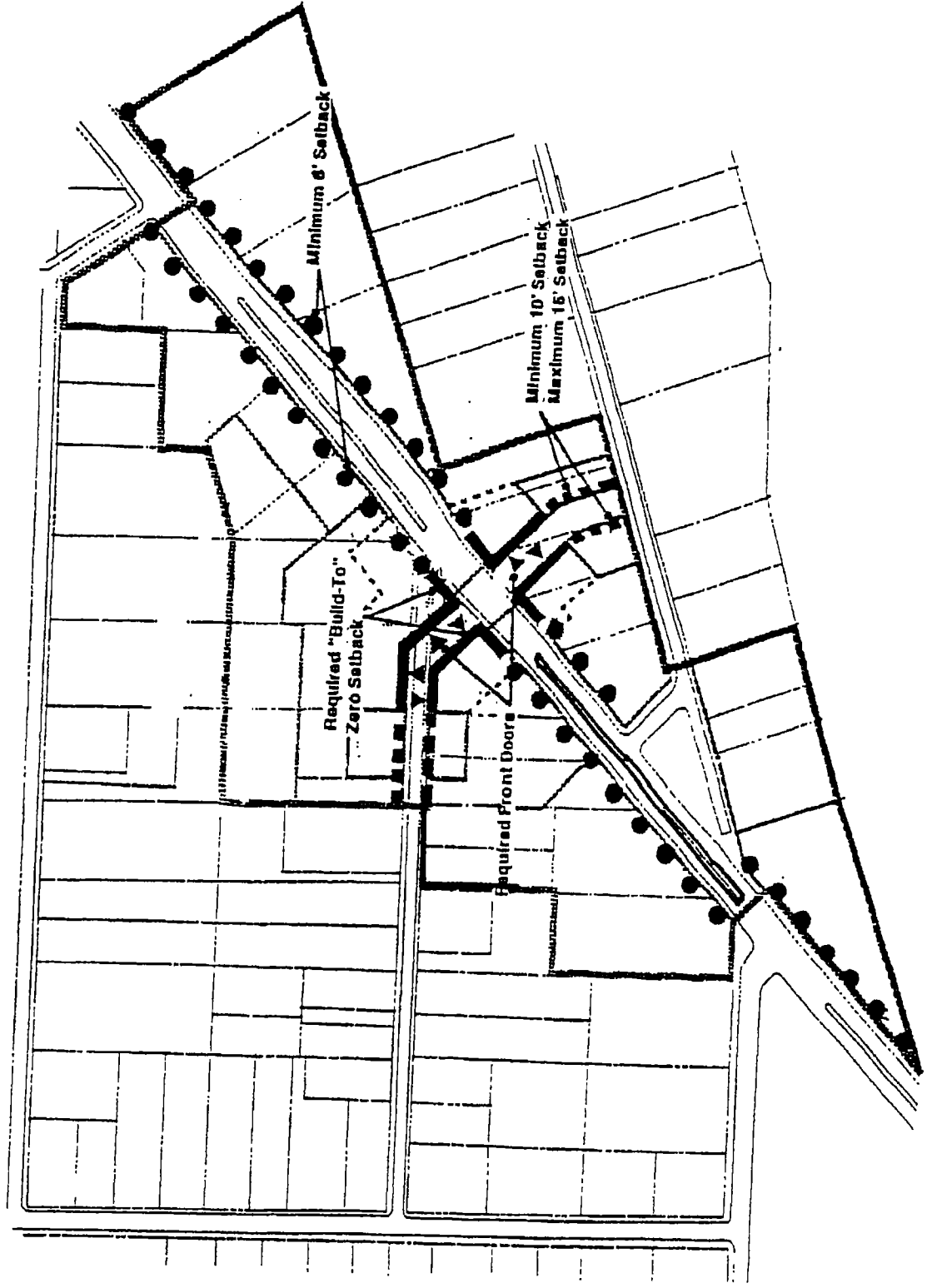

Figure 5

BUILDING WINDOW OPENINGS AND BLANK WALLS

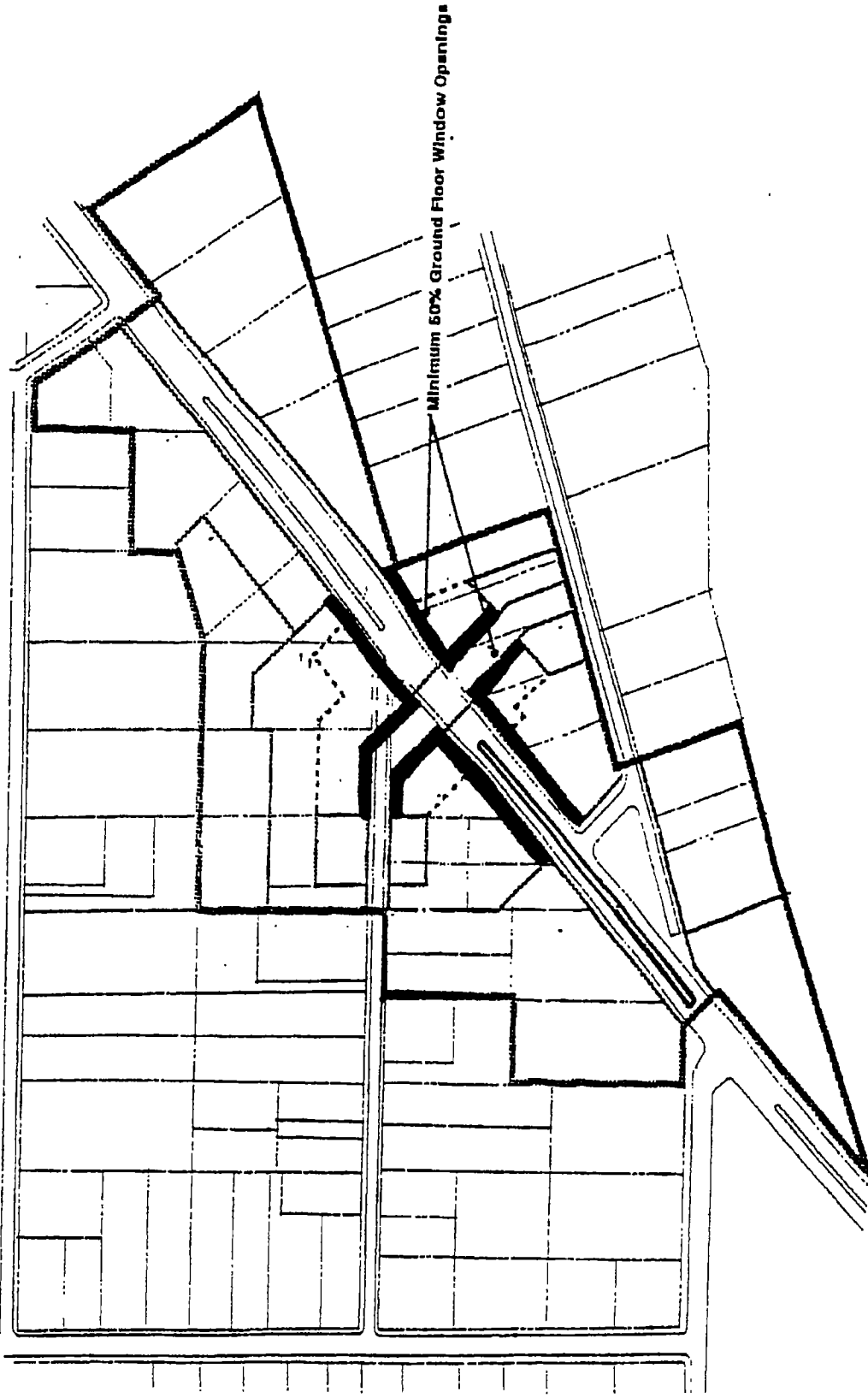
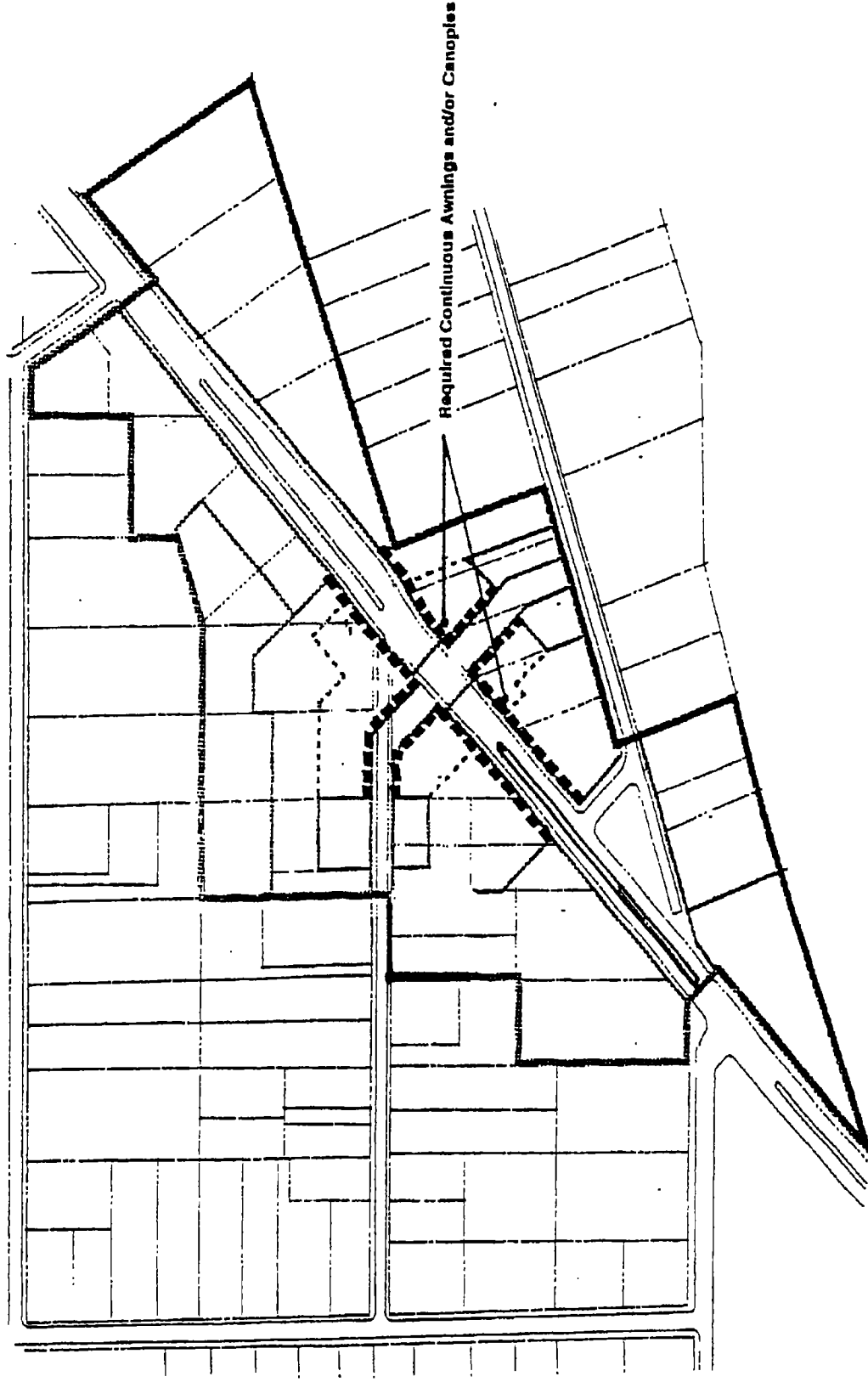

Figure 6

I/GM Quick Response

West Lake Grove Design District
Lake Oswego, Oregon

BUILDING RAIN PROTECTION



1/20/08 11:00 AM

Figure 7

REQUIRED STREET LIGHTING

