

TRIANGLES OF SOUL—SCHUBERT THE “WANDERER” AND HIS MUSIC

EXPLAINED BY NEO-RIEMANNIAN GRAPHS

by

KANAKO ISHIHAMA

A DISSERTATION

Presented to the School of Music and Dance
and the Graduate School of the University of Oregon
in partial fulfillment of the requirements
for the degree of
Doctor of Philosophy

September 2017

DISSERTATION APPROVAL PAGE

Student: Kanako Ishihama

Title: Triangles of Soul—Schubert the “Wanderer” and His Music Explained by Neo-Riemannian Graphs

This dissertation has been accepted and approved in partial fulfillment of the requirements for the Doctor of Philosophy degree in the School of Music and Dance by:

Jack Boss	Chairperson
Alexandre Dossin	Core Member
Drew Nobile	Core Member
Jeffrey Librett	Institutional Representative

and

Sara D. Hodges	Interim Vice Provost and Dean of the Graduate School
----------------	--

Original approval signatures are on file with the University of Oregon Graduate School.

Degree awarded September 2017

© 2017 Kanako Ishihama

This work is licensed under a Creative Commons
Attribution-NonCommercial-NoDerivs (United States) License.



DISSERTATION ABSTRACT

Kanako Ishihama

Doctor of Philosophy

University of Oregon, School of Music and Dance

September 2017

Title: Triangles of Soul—Schubert the “Wanderer” and His Music Explained by Neo-Riemannian Graphs

In Schubert’s music, the theme “wandering” is used frequently, closely related to human life and death. I presume that, being stricken by serious illness and facing challenging relationships, Schubert lived his short life with agony and dismay, confronting the life theme “death.” In that sense, Schubert himself was probably the wanderer who kept trudging throughout his life journey. In 1822, Schubert composed the allegorical tale “My Dream,” and in that tale, he writes as follows; “when I attempted to sing of love, it turned to pain. And again, when I tried to sing of pain, it turned to love. Thus were love and pain divided in me” (Deutsch 1977, 227). Schubert lived his life, struggling between love and pain, and between life and death. Human life and death conflict with each other, but exist together in the same place. In other words, death is a root of life. If one can perceive that life and death both exist at the root of one’s life, the form of life should be represented by a circular path, not by a linear formation. This notion accords with Schubert’s musical style, where the same material comes back again and again in a circular formation. I assume that the notion—death as a root of life—is the essential conception of “wandering” that

Schubert's music expresses. In this dissertation, I would like to offer several Neo-Riemannian analyses and graphs of Schubert's piano compositions; Impromptus D. 899, Moments Musical D. 780, Sonata in C-minor D. 958, and the "Wanderer" Fantasy D. 760. For each work and movement, I will map out the harmonic structure and key progressions on a *Tonnetz* graph, and suggest a new way to comprehend the nature of "wandering" that Schubert's music portrays. Through the configurations and harmonic motions on the *Tonnetz* graphs, I will establish a way to comprehend Schubert's concept of circular "wandering" visually and geometrically.

CURRICULUM VITAE

NAME OF AUTHOR: Kanako Ishihama

GRADUATE AND UNDERGRADUATE SCHOOLS ATTENDED:

University of Oregon, Eugene

DEGREES AWARDED:

Doctor of Philosophy, Music Theory, 2017, University of Oregon

Master of Music, Piano Performance, 2011, University of Oregon

Master of Music, Piano Pedagogy, 2011, University of Oregon

Bachelor of Music, Piano Performance, 2008, University of Oregon

AREAS OF SPECIAL INTEREST:

Neo-Riemannian Graphs and Analysis

Schubert's Piano Music

Harmonic Analysis

Schenkerian Analysis

Performance and Analysis

PROFESSIONAL EXPERIENCE:

Graduate Teaching Fellow in Music Theory, University of Oregon, 2011–2016

Rehearsal Pianist, the Corvallis Symphony, 2006

GRANTS, AWARDS, AND HONORS:

The Second Prize, MTNA Young Artist Piano Performance Northwest Division Competition, 2009

Concerto Competition, University of Oregon School of Music, 2009

Achievement Award, Outstanding Undergraduate Work in Keyboard Performance, University of Oregon, 2008

The First Prize, MTNA Young Artist Piano Performance State Competition, 2008

The Second Prize, MTNA/OMTA Gladys Strong Competition, Portland, 2008

Phi Beta Scholarship Award, Eugene, 2006

Ruth Close Musical Fellow Scholarship, 2005–2009

The Second Prize, Elizabeth Harper Vaughn Piano Concerto Competition, Kingsport, TN, 2005

The Second Prize, MTNA/OMTA Gladys Strong Competition, Portland, 2005

Awarded by Japan Piano Teacher's Association, Japan, 2001

ACKNOWLEDGMENTS

I wish to express my sincere appreciation and gratitude to Professor Jack Boss, who provided me his detailed comments, guidance and assistance during the whole process of creating this dissertation. I learned a lot from his teaching during this academic year of writing the dissertation and also during the past 12 years when I have taken several of his music theory classes. I am also grateful for the guidance that other dissertation committee members gave me. Professor Alexandre Dossin not only provided me his comments on this dissertation but also has taught me piano for the past 6 years. Professor Drew Nobile gave me detailed comments on this dissertation to help me refine both the texts and graphs. Professor Jeffrey Librett gave me helpful suggestions and comments to explore my ideas about the German literature and related concepts.

I also want to thank my parents, Kazuo Ishihama and Saeko Ishihama, for their support and immutable love.

To My Parents

TABLE OF CONTENTS

Chapter	Page
I. INTRODUCTION.....	1
II. THE CONCEPT OF “WANDERING”.....	14
“Wandering” Depicted in German Literature	14
“Wandering” Portrayed in Schubert’s Music	20
Schubert’s “My Dream”	26
Schubert’s Conception of “Wandering” and His View of Life and Death	35
III. SURVEY OF THE EXISTING LITERATURE.....	40
Charles Fisk’s Analysis	40
Rene Rusch’s Analysis	46
Jeffrey Perry’s Analysis	48
William Kinderman’s Analysis.....	50
Peter Pesic’s Analysis	52
John Bell Young’s Analysis.....	54
Richard Cohn’s Analysis	55
Michael Siciliano’s Analysis	57
Theodor Adorno’s Analysis	59

Chapter	Page
IV. IMPROMPTUS, D. 899 (1827).....	66
Impromptu D. 899-No. 1 in C Minor.....	76
Impromptu D. 899-No. 2 in E-flat Major	79
Impromptu D. 899-No. 3 in G-flat Major	83
Impromptu D. 899-No. 4 in A-flat Major	85
 V. MOMENTS MUSICAL, D. 780 (1823–28)	 101
Moment Musical D. 780-No. 1 in C Major	105
Moment Musical D. 780-No. 2 in A-flat Major.....	109
Moment Musical D. 780-No. 3 in F Minor.....	115
Moment Musical D. 780-No. 4 in C-sharp Minor	116
Moment Musical D. 780-No. 5 in F Minor.....	119
Moment Musical D. 780-No. 6 in A-flat Major.....	122
 VI. SONATA IN C MINOR, D. 958 (1828)	 129
Sonata in C minor D. 958, First Movement (Allegro).....	134
Sonata in C minor D. 958, Second Movement (Adagio).....	142
Sonata in C minor D. 958, Third Movement (Menuetto & Trio)	152
Sonata in C minor D. 958, Fourth Movement (Allegro).....	155

Chapter	Page
VII. THE “WANDERER” FANTASY, D. 760 (1822).....	163
The “Wanderer” Fantasy D. 760, First Movement (Allegro).....	166
The “Wanderer” Fantasy D. 760, Second Movement (Adagio).....	170
The “Wanderer” Fantasy D. 760, Third Movement (Scherzo).....	175
The “Wanderer” Fantasy D. 760, Fourth Movement (Finale; Allegro).....	178
VIII. SCHUBERT’S “WANDERING” EXPLAINED BY THE TRIANGLE CONFIGURATIONS.....	184
Flat-chord and Sharp-chord Ranges.....	185
Conflicting Keys—C major/minor Region vs C# minor/major Region.....	187
C major/minor as a Center of “Wandering”	193
Wanderer’s Journey Represented by the Triangle Configurations	194
Schubert’s “Wandering”.....	198
APPENDIX: SUPPLEMENTARY TEXT SOURCES	201
REFERENCES CITED.....	202

LIST OF HARMONIC & LINEAR GRAPHS

Graph		Page
4.1-A.	Impromptu D. 899-No. 1, Harmonic Transformation	77
4.1-B.	Impromptu D. 899-No. 1, Linear Framework.....	77
4.1-B'.	Impromptu No. 1, Linear Framework (more reduced version)	77
4.2-A.	Impromptu D. 899-No. 2, Harmonic Transformation	81
4.2-B.	Impromptu D. 899-No. 2, Linear Framework.....	81
4.3-A.	Impromptu D. 899-No. 3, Harmonic Transformation	84
4.3-B.	Impromptu D. 899-No. 3, Linear Framework.....	84
4.3-C.	Impromptu No. 3, Chord Transformation, mm. 78–81.....	85
4.4-A.	Impromptu D. 899-No. 4, Harmonic Transformation	87
4.4-B.	Impromptu D. 899-No. 4, Linear Framework.....	88
5.1.	Moment Musical No. 1, Harmonic Transformation	105
5.2.	Moment Musical No. 2, Harmonic Transformation	109
5.3.	Moment Musical No. 3, Harmonic Transformation	115
5.4.	Moment Musical No. 4, Harmonic Transformation	117
5.5.	Moment Musical No. 5, Harmonic Transformation	120
5.6.	Moment Musical No. 6, Harmonic Transformation	123
6.1.	Sonata in C minor, D. 958, first movement, Harmonic Transformation.....	140
6.2.	Sonata in C minor, D. 958, second movement, Harmonic Transformation.....	150

Graph	Page
6.3. Sonata in C minor, D. 958, third movement, Harmonic Transformation	154
6.4. Sonata in C minor, D. 958, fourth movement, Harmonic Transformation	159
7.1. The “Wanderer” Fantasy D. 760, first movement, Harmonic Transformation	169
7.2. The “Wanderer” Fantasy D. 760, second movement, Harmonic Transformation	175
7.3. The “Wanderer” Fantasy D. 760, third movement, Harmonic Transformation	177
7.4. The “Wanderer” Fantasy D. 760, fourth movement, Harmonic Transformation	180

LIST OF *TONNETZ* GRAPHS

<i>Tonnetz</i> Graph	Page
4.1. Impromptu D. 899-No. 1	79
4.2. Impromptu D. 899-No. 2	82
4.3. Impromptu D. 899-No. 3	85
4.4. Impromptu D. 899-No. 4	88
4.5. Impromptu D. 899 (Nos. 1–4).....	89
5.1. Moment Musical No. 1 (D. 780-1)	107
5.2. Moment Musical No. 2 (D. 780-2)	114
5.3. Moment Musical No. 3 (D. 780-3)	116
5.4. Moment Musical No. 4 (D. 780-4)	119
5.5. Moment Musical No. 5 (D. 780-5)	121
5.6. Moment Musical No. 6 (D. 780-6)	124
5.7. Moments Musical D. 780 (Nos. 1–6).....	126
5.8. Moments Musical D. 780, Shift between the principal keys	127
6.1. Sonata in C minor, first movement (D. 958-1)	141
6.2. Sonata in C minor, second movement (D. 958-2)	151
6.3. Sonata in C minor, third movement (D. 958-3)	154
6.4. Sonata in C minor, fourth movement (D. 958-4).....	160
6.5. Sonata in C minor D. 958 (1–4 movements)	162
7.1. The “Wanderer” Fantasy, first movement (D. 760-1)	170
7.2. The “Wanderer” Fantasy, second movement (D. 760-2).....	175

<i>Tonnetz</i> Graph	Page
7.3. The “Wanderer” Fantasy, third movement (D. 760-3)	178
7.4. The “Wanderer” Fantasy, fourth movement (D. 760-4)	180
7.5. The “Wanderer” Fantasy D. 760 (1–4 movements).....	183
8.1. C major→C# minor transformation supported by E major and Db major (<i>Wanderer</i> Fantasy).....	190

LIST OF DIAGRAMS

Diagram		Page
1.	Tonal Relation between the Movements (Impromptus D. 899)	67
1-A.	Updated Tonal Relation (Impromptus D. 899).....	74
2.	Intervallic relationships between the tonic keys (Moments Musical)	101
3.	Relation between the Movements (Moments Musical D. 780)	104
4.	C versus C# tonal regions in each work.....	193
5.	Returns of the opening key in C-minor sonata and Wanderer Fantasy	197

LIST OF EXAMPLES

Example	Page
4.1.	Impromptu in E-flat major, D. 899-No. 2, mm. 37–40..... 69
4.2.	Impromptu in G-flat major, D. 899-No. 3, mm. 53–56 69
4.3.	Impromptu in G-flat major, D. 899-No. 3, mm. 5–8 71
4.4.	Impromptu in E-flat major, D. 899-No. 2, mm. 77–88..... 73
4.5.	Impromptu in E-flat major, D. 899-No. 2, mm. 161–170..... 74
4.6.	Impromptu in E-flat major, D. 899-No. 2, mm. 125–137..... 80
4.7.	Impromptu in E-flat major, D. 899-No. 2, mm. 1–28..... 93
4.8.	Impromptu in A-flat major, D. 899-No. 4, mm. 107–116 95
4.9.	Impromptu in A-flat major, D. 899-No. 4, mm. 121–129 96
4.10.	Impromptu in A-flat major, D. 899-No. 4, mm. 1–30 99
4.11.	Impromptu in A-flat major, D. 899-No. 4, mm. 31–42 100
5.1.	Opening measures of Moment Musical No. 1 and No. 4..... 102
5.2.	Chromatic modulations in No. 2 and No. 6 103
5.3.	Moment Musical No. 1 (mm. 1–2; C major) 108
5.4.	Moment Musical No. 1 (mm. 30–31; G major)..... 108
5.5.	Moment Musical No. 1 (mm. 38–39; D major) 109
5.6.	Moment Musical No. 2 (mm. 1–4) 111
5.7.	Moment Musical No. 2 (mm. 18–21; B-section) 111
5.8.	Moment Musical No. 2 (mm. 56–73; returning B-section) 113
5.9.	Moment Musical No. 4 (mm. 176–180; coda)..... 118
5.10.	Moment Musical No. 6 (mm. 71–77; ending in Ab-minor) 123

Example	Page
6.1. Schubert, Sonata in C minor (D. 958), first movement, mm. 1–16.....	132
6.2. Beethoven, 32 variations, WoO 80, mm. 1–8.....	132
6.3. Sonata in C minor (D. 958), first movement, mm. 36–55	136
6.4. Sonata in C minor (D. 958), first movement, mm. 113–124	138
6.5(a). Sonata in C minor, first movement, mm. 14–15	143
6.5(b). Sonata in C minor, first movement, mm. 39–43	143
6.5(c). Sonata in C minor, second movement, mm. 1–4.....	143
6.6. Sonata in C minor (D. 958), second movement, mm. 8–19.....	144
6.7. <i>Winterreise</i> , “Gefror’ne Tränen”, mm. 7–18.....	145
6.8. Sonata in C minor, second movement, mm. 25–36	148
6.9. Sonata in C minor, second movement, mm. 51–55	148
7.1. “Der Wanderer”, D. 489, mm. 14–22	173
7.2. “Der Wanderer”, D. 489, mm. 23–30.....	173
7.3. The “Wanderer” Fantasy, D. 760, Adagio, mm. 189–197.....	174

CHAPTER I

INTRODUCTION

...I again wandered into a distant land. For long, long years I sang songs. When I would sing of love, it turned to pain. And again, when I would sing of pain, it turned to love. Thus love and pain divided me. (Solomon 1981, 137)

This is a part of an autobiographic story written by Franz Schubert on July 3rd, 1822, entitled “My Dream”. What is the mental dissociation torturing the protagonist in this story? It is the dissociation between love and pain, and between life and death, that are latent in human beings.¹ Every man lives his existence in supreme bliss, but at the same time, he lives his existence in excruciating pain. Every man struggles between these conflicting sentiments or experiences throughout his life. The ultimate form of such conflicting aspects is human “life and death.” Life and death are totally opposed to each other, but they actually exist in the same place simultaneously. They exist in the place where everything goes back to its origin and back to “nothing.” Human life begins in “nothing” and ends in “nothing,” and birth and death both come from the same place. In this respect, we can treat death as a root of life, and life and death are circularly linked to each other. A man lives between “life” and “death,” which conflict with each other, but

¹ When I write “love and pain, life and death,” I do not mean that these are exactly the same qualities—they are different since “love and pain” associates with a human’s internal sentiments while “life and death” is generally defined as a natural phenomenon that every human experiences. I line up these two, since both of these are conflicts of aspects described in Schubert’s “My Dream,” both as the inevitable experiences in the protagonist’s (or Schubert’s own) life, and as the important terms that show Schubert’s recognition of those as the aspects that conflict but are mutual to each other. Also, throughout this dissertation, I would like to use the term “life and death” not only as a general definition interpreted through the biological meaning, but also as the human’s internal or spiritual “life and death” in its philosophical meaning. That is why I use this term with quotation marks. This perspective is implied but not directly stated by Seishi Ishii in *Schubert—Pain and Love—*, 1997.

exist simultaneously. From the quoted sentences in Schubert's "My Dream," I sense a human soul hovering between life and death—a human soul in eternal "Circular Formation."

The theme used frequently, which is closely related to human life and death in Schubert's music, is that of "Wandering" or the "Wanderer," as Charles Fisk, Theodor Adorno and other scholars tell us. (See chapter 2 and 3 for more details on Fisk and Adorno's interpretations.) Schubert created a number of compositions with the theme of "wandering," including his song cycles *Die schöne Müllerin* D. 795, *Winterreise* D. 911, and other lieder such as "Der Wanderer" D. 489, "Der Wanderer" D. 649, "Der Wanderer an den Mond" D. 870, and "Wandrers Nachtlied" D. 224 and D. 768. What does the theme "wandering" or "wanderer" represent in Schubert's compositions? What does the theme "wanderer" mean to Schubert himself? No doubt it represents Schubert himself. Schubert suffered from serious disease from his youth to the end of his brief life (1797 to 1828). (He had a serious illness, probably syphilis, at least by 1823, but it has not become clear whether that is the cause of his death.) Schubert spent his whole life consistently at close quarters with death. Below is a part of Schubert's letter to Kupelwieser, written on March 31st, 1824.

...Picture to yourself someone whose health is permanently injured, and who, in sheer despair, does everything to make it worse instead of better; picture to yourself, I say, someone whose most brilliant hopes have come to nothing, someone to whom love and friendship are at most a source of bitterness, someone whose inspiration (whose creative inspiration at least) for all that is beautiful threatens to fail, and then ask yourself if that is not a wretched and unhappy being.

"Meine Ruh ist hin, mein Herz ist schwer, ich finde sie nimmer und nimmer mehr" ("My peace is gone, My heart is heavy, I will find it never and never more");

the opening lament in “Gretchen am Spinnrade,” originally from Goethe’s *Faust*.) That could be my daily song now, for every night when I go to sleep I hope never to wake again, and each morning I am only recalled to the griefs of yesterday...(Deutsch 1970, 78)

Death was always beside him throughout his life, and especially since he was stricken by illness, “death” had become the crucial theme of his life and of his music. To live with an incurable disease was certainly agony and torment to him, and this real experience greatly influenced his music. The same may be said of other composers. For example, the strong impression one often takes from Beethoven’s music is his representation of his agony and suffering coming from his real experience, taking the form of passing through torment and despair which leads to joy or gaining victory through experiencing torture. However, Schubert’s way of expressing his torment differs from Beethoven’s. Schubert’s music is not linked directly to his sentiments and emotions. Also, his music does not directly express the intensity of his conflicted feelings between despair and hope, like Beethoven portraying joy after agony. Rather, Schubert’s music seems to be detached from the direct expression of his own joy and sorrow, and it generalizes itself to represent all of human life itself instead. Such music comes from Schubert’s view of life and death. Through his life of struggling between love and pain, between life and death, he learned that the fulfilled life can be created by gazing at death. To live, he thoroughly confronted the life theme “death” throughout his life. His life was made meaningful by recognizing himself as an existence proceeding toward death and also as an existence coming from death. Life is created by death—that is the nature of human life he expressed in his music, and such a view was formational for his life and his music.

This notion—“death as a root of life”—accords with Schubert’s musical style. In his music, the opening material or phrase tends to come back again and again. Theodor Adorno points out that “Schubert’s forms are forms of invocation of what has already appeared” (Adorno 2005, 11). His themes always start from the same place and return to the same place. This circular musical style corresponds to the circularity between life and death, existing in the same place and linked to each other in an eternal cycle.

Furthermore, this endless cycle between life and death coincides with the concept of “wandering.” The wanderer represented in Schubert’s music does not have a place to go or a place to stay, but always in the depth of his heart, he seeks for a place to return to and a home that he can rely on, which is the root of his life. Every one spends his life wandering between life and death. Every one lives by gazing at the root of his life, as an existence toward death and coming from death. The theme “wandering” describes human life itself.

When I play and listen to Schubert’s music, it seems to have a quality of mystique, as if it were spreading out primordially, enfolding and transcending everything in this world. I suppose that his music evokes such a sense because his music depicts Schubert himself, who wandered through his life journey according to the circularity of human lives and who learned and communicated the primordial forms of life. In this dissertation, I would like to introduce a new way to comprehend the nature of “wandering”—the human soul in the eternal cycle between life and death—that Schubert portrays in his music. I will do this by analyzing some of Schubert’s instrumental compositions through Neo-Riemannian analyses and graphs, and show the harmonic circulations on the *Tonnetz* graphs that represent “wandering.” I will suggest a way to comprehend the nature of

“wandering,” through the triangle configurations and circular motions that appear on the *Tonnetz* graphs. The geometrical formation on the graphs will be shown to represent human life and death, which are in conflict but circularly connected to each other.

My dissertation will focus on harmonic and melodic analyses of the following works by Schubert; *Impromptus* D. 899 (1827), *Moments Musical* D. 780 (1823–28), *Sonata in C-minor* D. 958 (1828), and the “*Wanderer*” Fantasy D. 760 (1822). Each work is a set of different pieces, and all belong to Schubert’s late piano works. The main reason I chose these pieces is that it seems to me Schubert’s late works are heavily tinged with his concepts of “wandering” and “life and death.” The following paragraphs will present some brief introductory information pertaining to each of these pieces, mentioning their associations with the concept of wandering and the themes of life and death.

Many of Schubert’s piano works are organized as collections of short pieces, and his *Impromptus* D. 899, a set of four, became one of his masterpieces. Each of these four pieces is of great individuality. Schubert composed this work in or around 1827, shortly after he wrote his song cycle *Winterreise* D. 911. The influence of the song cycle is apparent in this music. William Kinderman states that “the rhythm (of the introductory phrase of *Impromptu* No. 1) is processional, and the atmosphere is that of a narrative, evoking the landscape of ceaseless wandering familiar from Schubert’s song cycles” (Kinderman 1997, 167). This opening rhythm with its “narrative” quality occurs throughout the piece (D. 899-No. 1), not only when the main theme comes back but also when the second section starts. The steady and consistent walking rhythm throughout the piece reminds us of a wanderer trudging around different lands. Also, the opening G

octaves instantly create a feeling of anticipation, sustained until measure 8; the long dominant pedal, resolving definitively to tonic only in m. 9, makes us think of a wanderer's stagnant emotion or his prolonged expectation for returning home. John Bell Young claims the importance of this G sonority as an interconnection between the sections. He writes that "the single sonority, G, is a motive in stasis that becomes in effect a center of gravity that continually irradiates its presence, and around which virtually every other constituent of the work is compelled to coalesce. Indeed, G-natural lurks in every crevice of this work" (Young 2009, 91). The formal structure of this piece could be interpreted as a theme and variations; the theme goes up to measure 41, followed by four variations.

The Impromptu No. 2 is in the traditional ternary form A(aba)-B(aa')-A(aba)-coda, where the middle B-minor section in dance-like rhythm is placed between the two A sections made up of rapid triplet passages. The A and B sections contrast with each other in their keys and rhythms, and this contrast acts as if it represents the two conflicting sides of human life, life and death. Young claims that the beginning section up to measure 23 gives a sense of anticipation like the bell effects in *Winterreise*, which indicates a "preoccupation with death". This leads to the middle B section in a drumroll-like rhythm (long-long-short-short-short-long) representing the death summons (Young 2009, 96). The rhythmic character and formal structure of this piece are much the same as that of Impromptu No. 4, where the outer A sections are made up of rapid right-hand passages and the middle B section presents a more serious and solemn flavor. No. 4 starts with a six-bar phrase with rapid sixteenth-note passages in the right hand in waltz-like rhythm. This six-bar theme is repeated several times in the first section, while modulating to

different keys. Young argues that this “restless migration from one key to another” represents “the Impromptu yearn[ing] for something it can never attain” and depicts the “Schubertian wanderer in search of belonging.”

The third Impromptu of D. 899 was published after Schubert’s death, by Tobias Haslinger when the new edition of this work was published in about 1857. (The original edition with only the first two movements was published by his father Karl Haslinger in 1827.) When Tobias Haslinger published it, this G-flat impromptu was rewritten in G-major, in order for amateur players to handle it easily. The time signature was also revised from 4/2 to 4/4. This revision was put back to its original G-flat version afterward. The lyrical quality and fluid texture of this piece create an aura of almost religious or sacred song. Young asserts that one of the elements portraying the “wanderer” scattered in this composition, the opening four repeated B-flats in dactyl rhythm in the right hand, is “a figure that gave life to Schubert’s ‘Fremdling’ in both the “Wanderer Fantasy” and its original lied “Der Wanderer” (Young 2009, 100). This dactyl rhythm is Schubert’s favorite motif to express the primordial forms of life and death, which is also used in many of his other compositions, such as *Moment Musical* No. 5 and “Wanderer” Fantasy.

Schubert’s *Moments Musical* D. 780 is also a set of different short pieces, like the *Impromptus* D. 899. Of the six pieces in D. 780, composed between 1823 and 1828, the last one in A-flat major was one of his earlier published pieces. This piece was published in 1824, as an independent piece entitled “Plaintes d’un Troubadour.” Like No. 6, the other five pieces can also be treated as independent pieces from each other even though each one is very short, because of the fact that these were written in different time periods

and because of their great characteristic individualities. Schubert's *Moments Musical*, as well as his *Impromptus*, became pioneering examples of the "character piece," a genre cultivated around this period. Considering the meaning of its title "Moment Musical," we assume that the composer was trying to portray the relation between "music" and "time (or a moment)." Music, generated in a moment and fading away in a moment, is very similar to the transience of human life. Music becomes beautiful and profound all the more for its momentary quality. I presume that Schubert comprehended this correspondence between the temporal qualities of music and human life. In May 1813, Schubert wrote a poem titled "Die Zeit (Time)" (Deutsch 1977, 31–32, translated by Eric Blom);

Unaufhaltsam rollt sie hin Nicht mehr kehrt die Holde wieder Stät im Lebenslauf Begleiterin Senkt sie sich mit uns ins Grab hernieder.	Unrelenting does she fly, Once departed, never tarrying. Thee, O fair companion of our days, To our resting-place we shall be carrying.
Nur ein Hauch! — und er ist Zeit Hauch! schwind' würdig ihr dort nieder Hin zum Stuhle der Gerechtigkeit Bringe deines Mundes Tugendlieder!	But a breath! — for such is Time. Let this breath sing worthy measures. To the throne of justice go thou forth, Voicing songs of virtue's heav'nly treasures!
Nur ein Schall! — und er ist Zeit Schall! schwind' würdig ihr dort neider Hin zum Sitze der Barmherzigkeit Schütte reuig Flehen vor ihm nieder!	But a sound! — for such is Time. Let this sound be music's treasure. To the seat of mercy go thou forth, Pouring out repentance without measure.
Unaufhaltsam rollt sie hin Nicht mehr kehrt die Holde wieder Stät im Lebenslauf Begleiterin Senkt sie sich mit uns ins Grab hernieder.	Unrelenting does she fly, Once departed, never tarrying. Thee, O fair companion of our days, To our resting-place we shall be carrying.

This poem seems to reveal Schubert's motto and how he lived in music. Music as a momentary art coincides with a moment in time and with momentary human life. Also, each moment of human life is built up in layers, creating a long lapse of time and the eternal cycle of human lives. In this sense, music is relevant to the nature of human life. By the title *Moments Musical*, I feel Schubert is expressing what it means to live in music. For him, the momentary quality of music and every moment of his life were relevant to each other and equally precious.

The Sonata in C minor, D. 958, is one of Schubert's last three sonatas, composed in 1828. His last sonatas were written just a few months before his death, and these are considered to be the pieces that portray the composer's remembrance of Beethoven, who died in 1827. The opening theme of D. 958 shows the strong influence of Beethoven's C-minor Variations, WoO 80. It becomes apparent that Schubert was immensely influenced by Beethoven and was showing his greatest respect to him. While every book and article on D. 958 claims the influence of Beethoven's compositions, the piece also reflects Schubert's own thoughts toward death. In "Returning Cycles," Charles Fisk writes that "this work begins with possibly the fullest and most explicit quotation of Beethoven in all of Schubert's instrumental music, but it also holds its deepest and most explicit memories of *Winterreise*" (Fisk 2001, 203). Fisk proclaims links between *Winterreise* and the C-minor sonata, especially connections between the fate of the wanderer in *Winterreise* and the final movement of the sonata, a tarantella, interpreted as a dance of death. Fisk states that "the protagonist of *Winterreise*...seeks to die, or perhaps to be reborn, but instead he endures a kind of living death. The C-minor sonata, suggesting access to such mysterious realms for its Schubertian protagonist, perhaps undertakes a resurrection, or at least a

validation, of this lonely outcast. Its final tarantella might signify not merely the wanderer's death, but a new-found access to realms of enlightenment, mystery, and terror, and a consequent ability to embrace death without feeling annihilated by the prospect of it" (Fisk 2001, 197).

Schubert composed his string quartet D. 810 "Death and the Maiden" on the theme of the "dance of death," similar to the tarantella of the C-minor sonata. In this work, "death" is not characterized as evil or sin, and "death" has no enmity toward the maiden. Death as portrayed in this work embraces the maiden who is mortal, and relieves her fear. It seems that Schubert depicts death as salvation or rest. Death is not the road to destruction or to a fate that one should fear, but a promise of rest and hope for eternal life. This concept of death accords with the concept of the eternal cycle between life and death. Human life is everlasting and perpetual, in the circular connection between life and death. Like "Death and the Maiden," Schubert's C-minor sonata probably reflects his approach to the concept of death.

In 1822, Schubert composed his "*Wanderer*" Fantasy D. 760, getting his inspiration from his song "The Wanderer," D. 489. The "*Wanderer*" Fantasy consists of four movements, and these movements are interconnected by the dactyl rhythm used in the outer movements. The Fantasy's central compositional technique is Schubert's use of thematic transformations. Each appearance of the theme is enriched by different harmonies and rhythms, presenting the same theme in varied, developed versions. While the thematic transformation shows a variety of scenes, as if the wanderer is meandering around different landscapes, Schubert consistently uses cyclical form, where the beginning material comes back repeatedly throughout the piece. This cyclic formation

characterizes the concept of wandering through its continual returning to the beginning, representing the circular life journey between life and death.

The song “Der Wanderer” D. 489, the inspiration for the piano fantasy, was composed in 1816, a setting of a famous poem by Georg Philipp Schmidt von Lübeck (1766–1849). Here is the poem by Schmidt;

Ich komme vom Gebirge her, Es ruft das Thal, es rauscht das Meer, Ich wandle still und wenig froh, Und immer fragt der Seufzer: wo?	I come down from the mountains, The valley dims, the sea roars. I wander silently and am somewhat unhappy, And my sighs always ask, “Where?”
--	---

Die Sonne dünkt mich hier so kalt, Die Blüte welk, das Leben alt, Und was sie reden, tauber Schall, Ich bin ein Fremdling überall.	The sun seems so cold to me here, The flowers faded, the life old, And what they say has an empty sound; I am a stranger everywhere.
---	---

Wo bist du, mein gelobtes Land, Gesucht, geahnt und nie gekannt?	Where are you, my dear land? Sought and brought to mind, yet never known,
Das Land, das Land so hoffnunggrün, Das Land, wo meine Rosen blühn?	That land, so hopefully green, That land, where my roses bloom,

Wo meine Träume wandeln gehn, Wo meine Todten auferstehn; Das Land, das meine Sprache spricht, Und alles hat, was mir gebricht?	Where my friends wander Where my dead ones rise from the dead, That land where they speak my language, Oh, land, where are you?
--	--

Ich wandle still und wenig froh, Und immer fragt der Seufzer: wo? Es bringt die Luft den Hauch zurück: Da, wo du nicht bist, blüht das Glück.	I wander silently and am somewhat unhappy, And my sighs always ask, “Where?” In a ghostly breath it calls back to me, “There, where you are not, there is happiness.”
--	--

(Translated by Paul Hindemith)

The wanderer depicted in this poem feels alienated, seeking for meaning and hope to live. A sense of alienation comes from the wanderer's realization of himself as the "fremd," the stranger, who has lost his place to belong. All his happiness has left him, and his life is just a deep torment of suffering. While the "Wanderer" Fantasy D. 760 was inspired by this despairing poem and the *lied* set to it, it seems that the wanderer portrayed in the "Wanderer" Fantasy shows a different kind of stance toward his life. By applying the cyclical form of recurring themes, the "Wanderer" Fantasy portrays the wanderer circling between life and death, gazing at the root of his life and recognizing his fate and his life affirmatively as a living existence and an eternal soul. In this sense, we probably could treat these two compositions, the lied "Der Wanderer" and the "Wanderer" Fantasy, as portraying different kinds of wanderers, where the Fantasy provides the wanderer the transcendental notion to live in an infinite stream of human life as opposed to the wanderer of the song, who is infinitely disappointed that he can't return home.

Even though these four compositions by Schubert are not performed with words or poems, they disclose their close connection to concepts of wandering and human life and death. Analysis of these compositions will reveal the nature of Schubert's portrayal of "wandering" and his way of life. The analyses and graphs I present in this dissertation clearly illustrate how Schubert depicts the essence of "wandering" in his music. The unique aspect of my analysis is its use of Neo-Riemannian graphs on a *Tonnetz* to comprehend Schubert's concept of "wandering" visually and geometrically, establishing a new and effective way to comprehend Schubert's music. I hope that this study will give

us a chance to reaffirm and re-appreciate the mystic attraction of Schubert's music and the "wanderer" Schubert himself.

CHAPTER II

THE CONCEPT OF “WANDERING”

What does the concept of “wandering” or “wanderer” mean and represent? The word “wanderer” suggests the image of a person meandering without having any destination or goal. Also, it seems that “wandering” not only means physical strolling, but it connotes a sense of mental wandering. Here is a dictionary definition of the verb “wander”: “Wander (verb)—to move slowly across or around an area, without a clear direction or purpose” (Longman Dictionary 1995, 1607). Also, in “The Wanderer’s Many Returns,” Jeffrey Perry describes the difference between “wanderer” and “tourist.” He writes that “the difference between wandering and touring is largely a matter of teleology. Tourists seek a change of scene and travel so that they can return home; Wanderers set forth without a pre-determined goal, although they may discover one *en route*” (Perry 2002, 374). Like Perry says, the word “wandering” means that one is meandering without any goal, but at the same time mentally seeking and hoping for something indefinite. What does the wanderer seek and hope for, through his wandering journey? What is the essence of “wandering”? In this chapter, I would like to discuss the nature of “wandering,” by considering the motif or theme of “wandering” used in 18th- and 19th-century German literature and in Schubert’s music and his writings.

“Wandering” Depicted in German Literature

Perry states that “the tourist is virtually a creation of Biedermeier bourgeois culture, while the wanderer is a Romantic archetype” (Perry 2002, 374). Perry’s assertion

is supported by the fact that “wandering” was one of the most frequent motifs in literature during the Romantic period. The typical literary genre cultivated in that period was the *Bildungsroman*, which portrays the life of a protagonist who progresses and develops himself through different experiences and encounters. This genre of “education or forming oneself” became one of the principal notions in German literature during the 18th and 19th centuries. It was established through the awareness of the importance of self-formation, which arose as a result of the 18th-century *Enlightenment*. The idea of Enlightenment liberated people from social and religious norms, and because of that, each one began to search for his or her position in society and the meaning of his or her existence in the society. Each one reconsidered their individuality and started to grope for the meaning of their own life.

In the genre of the *Bildungsroman*, the writers often depicted “wandering” as the life journey of a character who strolls around different lands for self-improvement and to find the meaning of his life. The best known *Bildungsroman* is “*Wilhelm Meisters Lehrjahre*” (1795–96) by Johann Wolfgang von Goethe. The story portrays the course of spiritual improvement and self-formation of a man, who was born in a wealthy merchant family, left his home, and wandered up and down through different lands. This long novel consists of eight volumes, and it attained a reputation as the preeminent *Bildungsroman*.

The story is about Wilhelm, who dreams of becoming a reformer in the theatrical world, against his father’s hope for him to succeed to the family business. After his separation from his lover Mariane and recovering from his illness, Wilhelm sets out on a journey of self-realization, still enthusiastic about the theater. Through the journey, he hopes to escape his life in the family business and open up a new vista of his future.

Andrew Cusack calls Wilhelm's journey "tacit rebellion," and says that "the journey becomes a substitute for revolt: because he dare not change his circumstances by tackling his father, the youth opts for a change of place" (Cusack 2008, 15). For Wilhelm, the journey means not only escaping the life mapped out by his father but also his expression of himself and his autonomy to carve his own path. Cusack writes: "Wilhelm believes that he represents an ideal of active purposeful behavior—the Enlightenment ideal—in terms of metaphors of gait and movement. For him an ethical ideal is represented in terms of an image of corporeal self-expression: the free man striving purposefully toward his goal" (Cusack 2008, 18). Even though his spontaneous action leads him on a journey toward becoming a Meister of the theater (as he thinks), as time goes by, the journey makes him waver on which way he should go. Through his experiences and encounters during the journey, he learns to live in society and starts to ask himself what his vocation really should be. Wilhelm's journey not only displays his spontaneous soul, but also draws from great influences that surrounding people and incidents have on him. In this sense, Wilhelm is portrayed as an existence in duality between spontaneity and passivity. This combination of spontaneity and passivity seems to depict the two aspects of a human life as wanderer; a journey that is initiated by oneself but is controlled by external reality and one's fate.

Goethe's "Wilhelm Meister" influenced many of his contemporaries, among them Ludwig Tieck. Tieck was impressed by Goethe's novel and decided to write his own *Bildungsroman* in 1795. Tieck's novel was titled "Franz Sternbalds Wanderungen" and was published in 1798 in two volumes. The novel was published as an incomplete work, which lacks a third volume that Tieck intended to write in his lifetime but was not able to.

Tieck wrote this novel with Goethe's "Wilhelm Meister" in his mind as a blueprint. The broad outline of Franz Sternbald's wandering in this novel resembles Wilhelm's journey in Goethe's. Tieck's "Franz Sternbalds Wanderungen" portrays the life journey of a man whose hope is to be a full-fledged artist, and the story is about the process of his training and self-formation. At the outset, Franz decides to leave his home to widen his knowledge and to improve his art skills in a foreign land. By exposing himself to a vagrant life with its many difficulties, he expects to become a Meister in the art world. He leaves his hometown Nuremberg and travels to numerous foreign countries. The story traces his journey passing through Holland, Alsace, and finally arriving at Rome. Franz's wandering is regarded as a journey of self-formation, like Wilhelm's in Goethe's novel. However, the purpose of Franz's wandering, originally self-improvement as an artist, gradually changes as the story goes. Through certain incidents, his journey acquires a new goal, that is, to search for his lover and his parents. In addition, as his journey gives him a new purpose, the story begins to incorporate multidimensional aspects—philosophical discussions of the meaning of life and the divine nature. Franz's wandering begins to be detached from his individual story and goes up onto the level of a philosophical discourse on human existence. This transformation into a more abstract region and Franz's journey toward his ambiguous objectives seem to display typical characteristics of Romanticism. Andrew Cusack describes the process as follows:

As the end of the journey recedes and its object becomes more nebulous, the anticipated reunion displaces all thoughts of structured, planned progress toward a vocational goal. Through Sternbald, Tieck is articulating a specifically Romantic conception of wandering. In contrast to the Enlightenment ideal of purposeful travel directed toward finite goals, Sternbald describes a non-

systematic form of wandering, presented as an end in itself (“die Kunst zu leben”) and as an unending process (“immer zu suchen”). (Cusack 2008, 63)

The wandering depicted in Tieck’s novel is open-ended in terms of its uncertainty of objectives. In this sense, Franz Sternbald’s journey summarizes the Romantic conception in itself as well as depicting the nature of wandering. Under the Romantic conception, the looseness of the determined goal provides the crucial meaning of “wandering.” Even though the wanderer does not obtain his objective, “wandering” itself is significant for the wanderer. This sense of pursuing opaque and uncertain objectives fits well with the Romantic conception of wandering.

Also, while Franz Sternbald’s journey proceeds toward his future, his wandering includes a sense of returning to his past, seeking for his origin and identity. Franz’s wandering shows not only his yearning for distant invisible objectives but also his desire to connect back to his origin. Cusack insistently describes the quality of this wandering as *circularity*. (I will talk more about how Schubert expresses circularity throughout this dissertation.) He writes that “the ideal form of the Romantic journey is the circle, the completion of which brings the protagonist both to his origins and to a higher existential level...the Romantic journey is determined by two separate and (usually) conflicting moments: a tendency to circularity and a tendency to infinity—centripetal and centrifugal moments respectively” (Cusack 2008, 63–64). The conception of “wandering” should be understood as a never-ending and circular process, the wanderer passing through to pursue his meaning of life.

In these two novels by Goethe and Tieck, the protagonists’ homecomings or their feelings of homesickness are portrayed as the notable scenes. In “Wilhelm Meisters

Lehrjahre,” the protagonist makes a break with the theatrical world and terminates his wandering to return to his home. “Franz Sternbalds Wanderungen” is an incomplete work because of its missing last volume, but the author writes in his postscript to the revised edition that the story’s ending in his mind is the protagonist’s returning to his home, Nuremberg, to find his father and marry. Both protagonists set forth on their journey to find their individualities through various experiences, but they finally choose to come home. Also, their longing for home is depicted throughout the stories. Their returning home and their longing for home seem to be portrayed as valuable actions for them to find the meaning of their lives. That is because their homes are where they were born and where the origins of their lives are. The returning to home portrayed in these stories does not necessarily result in the protagonists’ despair of losing their dreams, hopes, or objectives to live. Instead, they gaze at the roots of their lives, and comprehend and accept their vocations. And, they find their meaning of life within their given territories. In other words, within the finite world, they find the infinite way to live—infinity within finitude. Cusack writes that “Wilhelm may well relinquish his nomadic existence, but he will continue to view the world as a wanderer; that is to say, with a degree of circumspection, an awareness of the finitude of his own capacities” (Cusack 2008, 39). No one can choose his or her time and place to be born. No one can change the origin of his or her life. This is what is given to each person as his or her fate. But within this given fate and given territory, each one tries to seek for one’s meaning to live. This is what “wandering” means and represents for us. Also, “wandering” tells us of a real sense of individual life existing by means of each person’s “freedom.” To live freely does not mean to live in the endless infinite world. The true meaning of freedom is to live in a

finite world that has a limit. And, within this finite world, each one can live with an infinite creativity. According to this notion, human life or “wandering” is not represented as going out linearly toward the external world. Rather, it is represented by the circular formation that depicts the individual life living infinitely within a given territory.

Also, the “wandering” depicted in this literature shows its significance in the action of “wandering” itself. It seems that Goethe and Tieck try to find the story’s importance in the course of the wanderer’s journey, rather than in the objectives or goals of wandering. The wanderer might wander to pursue his dream or hope. He might wander to seek for his family or his lover. He might be seeking for the meaning of his life. Perhaps, he may not know the reason why he is wandering. But, the “wandering” itself, the path he takes, represents the wanderer’s life and himself. So, even if he cannot reach his goal or find the answer he is seeking for, his wandering is a proof of his life. Wandering is human life itself.

“Wandering” Portrayed in Schubert’s Music

The 18th- and 19th- century German *Bildungsroman* portrays the wanderer’s journeys as moving toward the protagonist’s dream and hope, or as wandering to find a way to live and the meaning of life. Schubert, on the other hand, often depicts the wanderer as a man who lives in dismay and loneliness, seeking for hope to live. In many cases, the wanderer is portrayed as an existence leading ultimately toward death. Also, Schubert’s wanderer is always seeking and longing for his home, where he can find peace of mind, removing his agony and despair. The representation of the wanderer is quite often seen in Schubert’s vocal music. He sets music to several poems written on the

theme of wandering. One of those works, entitled “Der Wanderer,” D. 649, was composed in 1819, and its poem is by Karl Wilhelm Friedrich von Schlegel (1772–1829);

Wie deutlich des Mondes Licht	How clearly the moon’s light
Zu mir spricht	speaks to me,
Mich beseelend zu der Reise;	Inspiring me to journey;
“Folge treu dem alten Gleise,	“Follow truly the ancient path,
Wähle keine Heimat nicht.	Choose no homeland whatsoever.
Ew’ge Plage bringen sonst	Otherwise the heavy days bring
Die schweren Tage;	Endless troubles;
Fort zu andern	Away, to the other
Sollst du wechseln, sollst du wandern,	Should you change, should you wander,
Leicht entfliehend jeder Klage.”	Lightly shedding every woe.”

Sanfte Ebb und hohe flut,	Gentle ebb and lofty flood,
Tief im Mut,	Deep in courage,
Wandr’ ich so im Dunkeln weiter,	I wander farther in darkness,
Steige mutig, singe heiter,	I climb bravely, singing cheerfully,
Und die Welt erscheint mir gut.	And the world seems good to me.
Alles reine	All pureness
Seh ich mild im Widerscheine,	See I softly in the twilight,
Nichts verworren	Without confusion
In des Tages Glut verdorren:	Fading in the day’s afterglow:
Froh umgeben, doch alleine.	Surrounded by joy, but alone.

(Translated by Richard Hurley)

In this poem, the wanderer tries to keep going forward without stopping at any place. The poem implies to us that the wanderer suffers torments, but the moon is advising the wanderer to proceed on his way in an intent manner, and that is the way he should go in order to live. The wanderer might expect that his hope to live or meaning to live will be found by continuing to meander. Although he wanders in darkness, he hopes

to move along. The poem gives us the scene of the moonlight tenderly bright in the sky, above the wanderer who is wandering alone. The moon in this poem acts as a calming influence, gently speaking to the wanderer. As in this poem, the interrelation between a wanderer and the moon is also featured in Schubert's "Der Wanderer an den Mond (The wanderer speaks to the moon)," D. 870. The song was composed in 1827, set to a poem by Johann Gabriel Seidl (1804–1875);

Auf Erden—ich, am Himmel—du
Wir wandern beide rüstig zu:
Ich Ernst und Trüb, du hell und rein
Was mag der Unterschied wohl sein?

I on the earth, you in the sky
We both wander briskly on:
I stern and troubled, you mild and pure;
What might be the difference between us?

Ich wander fremd von Land zu Land,
So heimatlos, so unbekannt;
Berg auf, Berg ab, Wald ein, Wald aus,
Doch bin ich nirgend, ach! zu Haus.

A stranger, I wander from land to land,
So rootless and unknown;
Up mountains and down, into forests and out,
But nowhere am I—alas!—at home.

Du aber wanderst auf und ab
Aus Ostens Wieg' in Westens Grab,
Wallst Länder ein und Länder aus,
Und bist doch, wo du bist, zu Haus.

But you wander up and down,
From the eastern cradle to the western grave,
On your pilgrimage from land to land;
And wherever you are, you are at home.

Der Himmel, endlos ausgespannt,
Ist dein geliebtes Heimatland;
O glücklich, wer, wohin er geht,
Doch auf der Heimat Boden steht!

The sky, endlessly spreading,
Is your beloved homeland;
O happy is he who, wherever he goes,
Still stands on native ground!

(Translated by Emily Ezuzt)

The poem depicts the wanderer speaking to the moon, making a comparison between himself, who has nowhere to stay, and the moon, which is at home consistently.

The moon in this poem represents the wanderer's dream or hope—he seeks for a home that he can rely on. Without any home to return to, the wanderer continues to stroll around different places. The moon is placed in the sky at all times, representing someone who has his home in his heart all the time. The wanderer, who is seeking for something that he can rely on, desires to be like the moon in the sky.

Schubert's "Wandrer's Nachtlied (Wanderer's Night Song)," D. 768 (1823) is another of his vocal pieces on the theme of wandering. The poem is by Johann Wolfgang von Goethe:

Über allen Gipfeln	Over all the peaks
Ist Ruh,	It is peaceful,
In allen Wipfeln	In all the treetops
Spürest du	You feel
Kaum einen Hauch;	Hardly a breath of wind;
Die Vögelein schweigen im Walde,	The little birds are silent in the forest...
Warte nur, balde	Only wait—soon
Ruhest du auch!	You will rest as well.

(Translated by Emily Ezuzt)

This short poem portrays a scene of the wanderer walking in quietness, without any sound of birds or wind. It seems that the word "rest" at the end of the poem represents the death of the wanderer. Death in this poem is not something threatening the wanderer, but is represented as rest and as the home he is seeking. As in Schubert's "Death and the Maiden" D. 810, which portrays Death embracing the maiden and leading her to rest for eternal life, the wanderer in this poem is going toward Death which gives him rest and hope.

Schubert's song cycles *Die schöne Müllerin* D. 795 and *Winterreise* D. 911 both

depict a wanderer's journey toward death. (The main character is still alive at the end of *Winterreise*, but one might say his soul has died.) *Die schöne Müllerin* was composed in 1823, set to poems by Johann Ludwig Wilhelm Müller. This song cycle is based on the story of a young miller who sets forth on a journey for training. During his journey, the miller meets a beautiful woman and falls in love with her. But his single-minded love is never fulfilled, and he throws himself into a brook. The miller's journey is full of hope at the outset, but with his broken heart, his hope turns to agony and despair. The first song of the cycle, "Das Wandern (Wandering)", starts as follows:

Das Wandern ist des Müllers Lust, Das Wandern!	Wandering is the miller's joy, Wandering!
Das muß ein schlechter Müller sein, Dem niemals fiel das Wandern ein, Das Wandern.	He must be a miserable miller, who never likes to wander. Wandering!

(Translated by Emily Ezuzt)

As the opening stanza shows, the wanderer starts his journey hopefully toward his goal to be a miller. He thinks that wandering for the purpose of self-training is necessary for millers, similarly to the characters in Goethe's and Tieck's stories. Wandering in this work is treated as the symbol of youth, and it depicts the young man's life journey with his hope of attaining his dream and love. Compared with this song cycle, Schubert's *Winterreise*, composed in 1827 on poems by Müller, gives a more dark and dismal atmosphere, portraying the protagonist's despair and hopeless life. While *Die schöne Müllerin* portrays the protagonist's hope at the outset, the wanderer in *Winterreise* has already lost his hope when he starts his journey. The wanderer's unrequited love leads him to the journey, and he wanders full of torment and despair, making his way toward

his ultimate death. Here are the opening stanzas of the first song of this cycle, “Gute Nacht (Good Night)”:

Fremd bin ich eingezogen,	I came here a stranger,
Fremd zieh' ich wieder aus.	As a stranger I depart.
Der Mai war mir gewogen	May favored me
Mit manchem Blumenstrauß.	With many a bunch of flowers.
Das Mädchen sprach von Liebe,	The girl spoke of love,
Die Mutter gar von Eh',	her mother even of marriage.
Nun ist die Welt so trübe,	Now the world is so gloomy,
Der Weg gehüllt in Schnee.	The road shrouded in snow.
Ich kann zu meiner Reisen	I cannot choose the time
Nicht wählen mit der Zeit,	to begin my journey,
Muß selbst den Weg mir weisen	must find my own way
In dieser Dunkelheit.	In this darkness.
Es zieht ein Mondenschatten	A shadow of the moon travels
Als mein Gefährte mit,	with me as my companion,
Und auf den weißen Matten	and upon the white fields
Such' ich des Wildes Tritt.	I seek the deer's track.
	(Translated by Celia Sgroi)

The opening sentence “I came here a stranger, As a stranger I depart” expresses the protagonist’s loneliness and alienation; his feeling of not belonging to or being part of his surroundings. He finds no place to belong to, and only lives to march toward death.

In *Die schöne Müllerin*, the miller drowns himself in a brook. The protagonist in *Winterreise* wanders toward his death. In both song cycles, the final destinations of the main characters’ journeys are their deaths. Wandering, or human life, proceeds toward death. Death comes to all human lives, and we cannot change this fate. However, within our limited span of life, each person seeks for his or her purpose to live. And to live one’s

life means to gaze at one's identity and the root of one's life. For the wanderer, his home is the place that he can mentally rely on. To think of his home is to look at the root of his life. The moon in "*Der Wanderer an den Mond*" is depicted as a wanderer who always feels at home, or who has her home in mind continually. (The moon in Romantic literature is usually portrayed as female.) For the wanderer who has nowhere to stay and seeks for a place to rely on, the life of the moon is his ideal and what he longs for. The wanderer in these songs, who longs for his home while proceeding toward death, could be a reflection of the composer Schubert himself. Charles Fisk writes; "As a man without consistent family support, without a home he could call his own, without even the memory of fulfillment in love, and as a man afflicted with a life-threatening and socially stigmatized disease, Schubert is likely to have harbored potentially overwhelming impulses to represent himself, in at least some of his fragmentary imaginary narrations of his own life, as a Fremdling" (Fisk 2001, 269). The feeling of despair and agony expressed in *Winterreise* reflects Schubert's dismay toward his illness and threatening death. Also, the wanderers' loneliness and feeling of alienation seems to parallel Schubert's hopeless emotions regarding death. But, despite his despairing life, Schubert continued to seek for his mental home and his meaning to live by looking for the root of his life, as the wanderer in the song longs for home. With his life approaching death, Schubert tried to find what his life means by telling his own story through the wanderers in these songs.

Schubert's "My Dream"

Schubert did not travel or stroll very often during his life. Also, he never had a

wandering journey like the ones portrayed in *Die schöne Müllerin* or *Winterreise*. For Schubert, “wandering” did not signify an actual physical journey meandering around foreign lands. Instead, “wandering” represented his life itself. The allegorical tale “Mein Traum (My Dream)” written by Schubert in 1822 depicts the main character’s wandering, expressing conflict and anguish as he struggles between love and pain. Although this tale is not entirely autobiographic, it is a clear description of Schubert’s conception of “wandering.” I mentioned part of this tale in the opening chapter, but below is the full text (Deutsch 1977, 226–228, Translated by Eric Blom).

My Dream

3rd July 1822.

I was the brother of many brothers and sisters. Our father and mother were good people. I was deeply and lovingly devoted to them all.—Once my father took us to a feast. There my brothers became very merry. I, however, was sad. Then my father approached me and bade me enjoy the delicious dishes. But I could not, whereupon my father, becoming angry, banished me from his sight. I turned my footsteps and, my heart full of infinite love for those who disdained it, I wandered into far-off regions. For long years I felt torn between the greatest grief and the greatest love. And so the news of my mother’s death reached me. I hastened to see her, and my father, mellowed by sorrow, did not hinder my entrance. Then I saw her corpse. Tears flowed from my eyes. I saw her lie there like the old happy past, in which according to the deceased’s desire we were to live as she had done herself.

And we followed her body in sorrow, and the coffin sank to earth.—From that time on I again remained at home. Then my father once more took me to his favourite garden. He asked whether I liked it. But the garden wholly repelled me, and I dared not say so. Then, reddening, he asked me a second time: did the garden please me? I denied it, trembling. At that my father struck me, and I fled. And I turned away a second time, and with a heart filled with endless love for those who scorned me, I again wandered far away. For many and many a year I sang songs. Whenever I attempted to sing of love, it turned to pain. And again, when I tried to sing of pain, it turned to love.

Thus were love and pain divided in me.

And one day I had news of a gentle maiden who had just died. And a circle formed around her grave in which many youths and old men walked as though in everlasting bliss. They spoke softly, so as not to wake the maiden.

Heavenly thoughts seemed for ever to be showered on the youths from the maiden's gravestone, like fine sparks producing a gentle rustling. I too longed sorely to walk there. Only a miracle, however, can lead you to that circle, they said. But I went to the gravestone with slow steps and lowered gaze, filled with devotion and firm belief, and before I was aware of it, I found myself in the circle, which uttered a wondrously lovely sound; and I felt as though eternal bliss were gathered together into a single moment. My father too I saw, reconciled and loving. He took me in his arms and wept. But not as much as I.

No one knows whether this tale relates Schubert's actual experiences or not. If it is not his personal experience, then it might be a description of a dream he had, or a fictional story. Otto Erich Deutsch tells us that the original manuscript of this tale was written in pencil, and Ferdinand Schubert (Franz's brother) added its title and the name "Franz Schubert" in ink. Ferdinand brought this manuscript to Schumann on January 7th, 1839, and Schumann published it in his journal *Neue Zeitschrift für Musik*. Deutsch mentions Schubert's stepbrother Anton's statement that "Schubert had been twice expelled from his parental home." Deutsch explains this in more detail in his book *Franz Schubert's Letters and Other Writings*; He writes that this allegorical story is "founded closely on fact. When Schubert was still at the Choir College he neglected his other studies for music, and as a punishment, it is supposed, his father forbade him the house. Elisabeth Schubert's sudden death softened her husband's heart. The ban was removed, and Franz was even permitted to study under Salieri. The second quarrel between father and son, which lasted three years, broke out in 1818 when Schubert refused to return to the

“pleasure-garden,” otherwise the School-house, and went off instead to Zelez” (Deutsch 1970, 59).

“My Dream’s” autobiographical significance has been discussed by several scholars. Charles Fisk states that the story corresponds to Schubert’s real life, though he writes that “on the basis of biographical information alone, the so-called “external events” of Schubert’s life, one cannot read this story unambiguously as an autobiographical statement” (Fisk 2001, 270). Fisk writes that “the story corresponds in some, although clearly not all, respects to Schubert’s life. He did quarrel with his father over his musical aspirations and left home for several extended periods in order to pursue them” (Fisk 2001, 9). Although we cannot declare that the entire story corresponds at every point to Schubert’s life, banishments from his father’s home and his mother’s death are things that Schubert actually experienced. Fisk says that the story “suggests Schubert’s feelings of estrangement from his father as a possible source for his identification with the Fremdling wanderer of this tale” (Fisk 2001, 8). Maynard Solomon also states that the story is “not only a retrospective account of Schubert’s alienation from his father, but also a prospective allegory expressing his profound wish to return to the paternal bosom” (Solomon 1981, 150). As mentioned above, the conflict between Schubert and his father actually happened. As Schubert’s several biographers mention, his father Franz Theodor was a music lover and recognized his son’s musical talent, but he was not completely in favor of Schubert’s life as an artist. As a school-teacher, Franz Theodor wanted his son to live as an educator and lead a steady life. Solomon writes that “from the surviving documents, it seems that two of the boys—Ferdinand and Karl—were content, perhaps even eager, to walk in their father’s footsteps, but that the firstborn,

Ignaz, and Schubert, resisted their father's wishes, with varying degrees of success" (Solomon 1981, 139). In fact, the central events portrayed in "My Dream" are the protagonist's conflict with his father, his exiles, and reconciliation. The reconciliation with his father at the end of this story may or may not be an actual event that happened to the main character. It may be an illusion or vision coming from the protagonist's hope to be loved by his father. Solomon says that the story "expresses Schubert's wish to submit to his father and thereby gain his love. Fear of separation from father is central here" (Solomon 1981, 146).

It is uncertain whether Schubert's "My Dream" is an autobiographical account of his life or not. However, what is more important in my argument is to understand Schubert's view of life and artistic conception from this tale. From this short allegorical story, we can grasp Schubert's view of life and death, his conception of wandering, and what music means to him.

In this story, the protagonist sings songs for many years after the second banishment. These songs come from his mental conflict and torment, his struggle within himself between pain and love. Fisk says that "his music (singing) apparently takes control of his emotions, transforming his love into pain and his pain into love" (Fisk 2001, 10). The main character's song represents the cry of his soul, and it is also a song expressing his craving coming from his agony. The song is the representation of his wandering soul, showing his deep grief for the conflict with his father and the farewell forever to his mother. This song also shows his invocation for relieving himself from his mental torments and despairs. Solomon writes that "here, song represents the state of exile, and exile in turn motivates a cluster of desires—to return home, to resurrect the

mother, and to revive the “happy old past,” which is to say, the preoedipal period idealized in memory” (Solomon 1981, 149). The song itself is the expression of the protagonist’s mental conflict. He is longing for his home, loving his parents, and retracing his past days, and by doing so, his mental conflict and despair becomes more intensified, sticking like a knife into his heart. Like the main character’s song which comes from his mental conflict, for Schubert, his music is the expression of the despair and distress of his heart, of Schubert himself.

Also, at the end of “My Dream,” the protagonist hears a “lovely sound” when he finds himself in the circle around the maiden’s gravestone. Here, Schubert writes that the main character “felt as though eternal bliss were gathered together into a single moment.” This sentence reminds us of the poem “Die Zeit” by Schubert. (Please see page 8 of this dissertation for the entire poem.) Fisk says that “in the final scene of salvation, his awareness of the “lovely sound” marks the moment—one might even call it a ‘moment musical’—of his entrance into the blessed circle” (Fisk 2001, 10). Just as Schubert titled some of his music “Moment Musical,” each moment of his life was valuable for him. Music is momentary like the flow of time, but this makes music precious and beautiful. The music which the protagonist hears at the end of his journey in the final scene is the music “in a moment,” precious because of its transient nature. For Schubert, music was valuable in the same way every moment of his life was.

In “My Dream,” Schubert portrays two different understandings of death. In this story, there are two scenes dealing with “death”—one is the scene of his mother’s death and another is the scene of the maiden’s death. At the death of the mother, the main character “followed her body in sorrow,” and his “tears flowed from his eyes.” “Death”

as portrayed in this scene emphasizes sorrow and despair at the separation forever from his mother, sentiments coming from “death” as a reality. In contrast, in the final scene at the maiden’s gravestone, people “walked as though in everlasting bliss,” and “heavenly thoughts seemed for ever to be showered on the youths from the maiden’s gravestone, like fine sparks producing a gentle rustling.” Death as portrayed in this scene is not a representation of despair or destruction, but of salvation and consolation. After the scene at the maiden’s gravestone, the protagonist reconciles with his father and confirms his father’s love. Through entering the circle around the maiden’s gravestone in a moment, he revives as a new soul, overcoming his mental conflict between love and pain. And, with his reborn soul, he reaffirms his father’s love. That is to say, “death” in the final scene acts as salvation as well as rebirth. Fisk writes of *Winterreise*’s main character that “by renouncing the desire that can lead only to death, he can perhaps be reborn, and thus recreate himself within the imaginary home-land of his art. In [Schubert’s allegory] “Mein Traum,” the final scene might figure as that home-land itself—the dead maiden as the muse, the circle of men other artists, here all reconciled for a common redemptive cause...the protagonist is reborn” (Fisk 2001, 11). Death is inevitable, bringing us feelings of despair and heartache. But, when we consider death as the moment producing a new life, death becomes something that consoles and salves our mind. In “My Dream,” Schubert describes death as a hopeless reality as well as a salvation of people’s minds and a source of life.

The tale’s most significant aspect is the main character’s “love and pain.” Through the story of the protagonist struggling between these two aspects, Schubert describes what “wandering” is for him. “Love and pain” in this story mean conflicting aspects

which are, however, linked to each other. “Love” is something every person holds in his or her heart, what he or she offers to others and receives from others. But, “love” sometimes turns to wounds or bruises in one’s heart. Life is full of struggles between these conflicting aspects.

Schubert often portrays such conflicting aspects in his compositions, showing that “love” and “pain” are actually connected to each other. William Kinderman says that “Schubert conveys with particular power in *Winterreise* the duality between the inner world of the imagination—dreams, aspirations, and bright memories—and the outer world of external reality” (Kinderman 1997, 209). Here, it seems that Kinderman claims both conflict and connection between internal imagination and external reality—the despairing reality of the main character (of *Winterreise*) proceeding toward death, and his internal aspiration for seeking salvation. These external and internal aspects in *Winterreise* are conflicting but connected to each other. Kinderman continues that “the very first word of the first song of *Winterreise*, “Fremd,” triggers or motivates the minor mode and dissonant inflections of “Gute Nacht”: only in the last strophe, with its ironic reference to the beloved, does the music turn to the major...A full-bodied resonance of sound with major harmonies is often reserved in *Winterreise* for dreams, visions, or bright recollections...” (Kinderman 1997, 210–211). By using major and minor modes, Schubert portrays the wanderer’s despair coming from his reality and his internal sentiments looking for salvation and solace, which conflict with each other but coexist in the wanderer’s life. In the same way, Schubert uses the contrast between B minor and C major, in “Irrlicht” from *Winterreise*, to depict the wanderer’s conflicting emotions. In addition, setting the words “Every river flows to the sea” in the third stanza, Schubert

creates a rising contour in the music, pushing up against the poem's "river flowing down to the sea." By doing so, he displays the connection of conflicting sentiments in the wanderer's mind. Also, a similar text-painting technique can be seen in his song "Ihr Bild" from the cycle *Schwanengesang*, where Schubert portrays the contrast between the protagonist's state of grief after the loss of a loved one and his dreamy vision of her image in his heart. Schubert depicts the protagonist's conflict between his reality and dream by means of the contrast of minor/major modes. In the following chapters, I will also discuss the contrast between C major and C# minor, which prominently appears in the "Wanderer" Fantasy. (Charles Fisk also mentions this in his book, calling C# minor the "Wanderer's" key. See Chapter 3 for more about his analyses.) The C# minor, which is the principal key of the song "Der Wanderer" and the "Wanderer" Fantasy's second movement, represents the wanderer's despairing sentiments in reality, contrasting to the C major representing his hopes and dreams.

The conflicting aspects—despair and salvation, dream and reality, and love and pain—portrayed in "My Dream" are inevitable experiences and sentiments in our life. Between these conflicting but linked aspects, we wander, and that wandering represents our life itself. The ultimate aspects are "life" and "death," the opposite extremes of human life. As mentioned above, Schubert comprehends death as the root of life and tries to create a fulfilled life by gazing at death. Human life, wandering between life and death in a circular path, is what Schubert depicts in his music. And this is the reflection of Schubert himself.

Schubert's Conception of "Wandering" and His View of Life and Death

For Schubert, the "wanderer" is the representation of himself. The wanderers who wander between life and death are images of Schubert himself, who spent his life at close quarters with death. Schubert, who writes "every night when I go to sleep I hope never to wake again, and each morning I am only recalled to the griefs of yesterday..." in his letter (see page 2–3 of this dissertation), must have an unendurable dismay at the thought of approaching death. This despair was consistently in Schubert's mind, torturing him. At the same time, he tried to apprehend "death" as a way toward rebirth. That is to say, every life proceeds to death, but also every death proceeds to life. Schubert wrote a poem entitled "Mein Gebet (My Prayer)" on May 8th, 1823 (Deutsch 1977, 279; translated by Eric Blom):

Tiefer Sehnsucht heil'ges Bangen
Will in schön're Welten langen;
Möchte füllen dunklen Raum
Mit allmächt'gem Liebestraum.

Großer Vater! reich' dem Sohne,
Tiefer Schmerzen nun zum Lohne,
Endlich als Erlösungsmahl
Deiner Liebe ew'gen Strahl.

Sieh, vernichtet liegt im Staube,
Unerhörtem Gram zum Raube,
Meines Lebens Martergang
Nahend ew'gem Untergang.

Tödt' es und mich selber tödte,
Stürz' nun Alles in die Lethe,

With a holy zeal I yearn
Life in fairer worlds to learn;
Would this gloomy earth might seem
Filled with love's almighty dream.

Sorrow's child, almighty Lord,
Grant Thy bounty for reward.
For redemption from above
Send a ray of endless love.

See, abased in dust and mire,
Scorched by agonizing fire,
I in torture go my way,
Nearing doom's destructive day.

Take my life, my flesh and blood,
Plunge it all in Lethe's flood,

Und ein reines kräft'ges Sein
Lass', o Großer, dann gedeih'n.

To a purer, stronger state
Deign me, Great One, to translate.

This poem is Schubert's prayer for the rebirth given to each one after death, and it comes from Schubert's dismal sentiments in the depth of his heart. Considering death as the path to new life agrees with the conception "fulfilled life created by gazing at death." By comprehending death as the path to life, every day of life becomes an end as well as a beginning. Because there is a link between life and death, human life becomes eternal and transcendent. Schubert, as he portrayed in "My Dream," wandered between love and pain, life and death, and lived his life by gazing at death in reality. And he incorporates such a view of life and death into his music. Jonathan Dunsby states, "Death in Schubert's emotional world, the world into which the music invites us, is not a grim fact observed in anticipatory terror or in an imagined, remembered shock; for Schubert, death is a "reality" through which, ironically enough, we have no choice but to live" (Dunsby 2005, 42). For Schubert, death was the ultimate experience of his life. Despite his despair about death, he did not stop confronting it and accepting its reality, and continued to live his life. Also, by accepting the reality of "life and death" and comprehending human life as an everlasting cycle, he enabled death to transform despair into consolation. This way of viewing human life, with the concept of life and death connecting to each other, leads Schubert to create his music as the depiction of human life itself.

The form of "wandering" that Schubert portrays in his music represents a person who wanders between life and death, but Schubert's conception of wandering transcends life and death. In Theodor Adorno's dissertation "Schubert," he describes Schubert's "wandering" as "der zeitlose kreislaufhafte Umgang zwischen Geburt und Tod (The

timeless circular path between birth and death)” (Adorno 2005, 10). Seishi Ishii explains Adorno’s expression as follows: “Musical performance involves time. Human life also involves time. However, this music (where the cycle between birth and death happens) is timeless performance in time. This is the place located between birth and death, and this place exceeds birth and death” (Ishii 1997, 311).

Human life has its end in terms of a temporal limit. Death inevitably comes to every life, and the span of human life cannot be extended. But, within the limited span of life, one can live with infinite possibilities and creativities. In this sense, human life involves time, but it is also timeless. It is finite, but is infinite simultaneously. And, human life wanders and lasts forever in the circulation.

Adorno calls the scenes of wandering in Schubert’s music “the landscape of death.” He explains his interpretation of this “landscape” as follows: “Remember that both of the great cycles (*Die schöne Müllerin* and *Winterreise*) are stimulated by poems in which again and again images of death appear before the person who sees them and who wanders among them... Brook, mill and black winter wastes, expanding in the *Nebensonnen* (the false sun: the motif of the 23rd song of the *Winterreise*) twilight, as in a dream, outside time—these are the signs of Schubert’s landscape, dried flowers are its mournful bloom; the objective symbols of death trigger the images, and the feeling of those images reinforces the symbols of death” (Adorno 2005, 10).

Adorno writes about the wanderer’s moving around different lands in the “landscape of death,” considering the physical location and trajectory of the wanderer in that landscape. He says that “the ex-centric construction of that landscape, in which every point is equally close to the center, reveals itself to the wanderer walking round it with no

actual progress: all development is antimatter, the first step as close to death as the last, and the scattered features of the landscape are scanned in rotation by the wanderer, who cannot let go of them” (Adorno 2005, 10). This represents the essential quality of “wandering.” As the wanderer of *Winterreise* lives in wandering, being close to death all the time, *every day and every moment in one’s life is equally close to one’s death*. In that sense, we can live every day and every moment as precious ones coming from our death, and we can treat each day and moment as the end but leading to the beginning as well. Seishi Ishii writes that ““Wandering” means that one is meandering step by step, recognizing himself as an existence proceeding toward death, as well as an existence coming from death. *In both music and human life, every point is equally close to death*. That means, in eschatological thinking, we should treat those “points” as a radical negation and also as a radical affirmation” (Ishii 1997, 279). If one can regard his or her life as coming from death, and can realize that life and death both exist at the root of one’s life, life should be represented by a circular formation, rather than by a linear path.

“Wandering” is human life itself. Everyday life is wandering. Many historical figures have argued the human life as “wandering.” Some of the great authors of Japan have also regarded human life as a journey. For example, Bashō Matsuo (1644–94), famous poet and master of haiku, begins his work *Oku no Hosomichi* (“The Narrow Road to the Interior”), which is in the form of a travel diary, with these sentences: “The months and days are the travelers of eternity. The years that come and go are also voyagers. Those who float away their lives on ships or who grow old leading horses are forever journeying, and their homes are wherever their travels take them.” *Oku no Hosomichi* is a poetic work by Bashō, who traveled around different places and regarded the flow of time

as a journey. This notion is remarkably similar to the German Romantic conception of “wandering.” In this conception, every human life is a wandering journey which has no end.

The wandering that Schubert portrays in his music describes human life itself. Human life has a potential infinite creativity expressed within a finite life span. This infinite/finite life is just like the musician’s process of producing infinite music with infinite creativity, on the keyboard—within eighty-eight keys which are finite. Also, musical performance is a momentary art, therefore, it greatly and profoundly touches one’s heart and stays in one’s heart eternally. It is the same as human life. “The timeless circulation between life and death” exists within the finite span of life, and this wandering circulation continues forever. Like the wandering between love and pain portrayed by Schubert, human life is wandering as an eternal soul, in the circular formation between life and death which conflict with and are connected to each other. The image of the wanderer who wanders while picturing his home in his mind, and the image of a human life wandering between life and death—these are represented by everlasting circularity.

In chapters 4 to 8, I will demonstrate this circular formation of human life and death, through the geometrical formations on Neo-Riemannian graphs. The configurations on the *Tonnetz* graphs will give us a way to visually comprehend Schubert’s “circular wandering.”

CHAPTER III

SURVEY OF THE EXISTING LITERATURE

In Chapter 2, I discussed Schubert's view of life and death—as a cycle that is eternal within the finite world. As Schubert lived his life in a struggle between love and pain, every human constantly struggles between conflicting aspects and feelings, and lives as a wanderer who wanders between the opposite extremes of his or her life—life and death. This cycle of human life is represented by a circular configuration where life and death link to each other, rather than by a linear formation. Adorno expresses it as “the timeless circular path between birth and death,” and it is the wanderer's journey which continues forever in endless circulation, in which “every point is equally close to the center” (Adorno 2005, 10).

In Schubert's music, the wanderer's journey is represented by particular musical forms, rhythms, and modulations, and different musical scholars have explored such musical techniques in Schubert's music. This chapter will describe those studies of Schubert's music, especially analyses that focus on the relationship between Schubert's music and the concept of wandering. At the end of the chapter, I will discuss how my work builds upon and extends beyond that of previous scholars.

Charles Fisk's Analysis

Fisk's analysis in his article “Returning Cycles” (Fisk 2001) demonstrates links between Schubert's story “My Dream” (this whole story is provided in my Chapter 2, pp. 27–28) and his music, while discussing the aspects of “wandering” found in Schubert's

late works. Fisk says that Schubert's music itself portrays "wandering," and the wanderer in Schubert's music always seeks for his home or the path to return to his home. Fisk writes that "Schubert's music can seem to wander, but its wandering remains constantly and poignantly aware either of its distance from home or (as an aesthetically intended effect) of having lost its way, and it continually searches for paths of return" (Fisk 2001, 19). The wanderer's homecoming is portrayed by cyclic organization in Schubert's music. This cyclic organization accords with Adorno's concept of the circular landscape of death. The essence of "wandering" is formed by a cyclic structure where the wanderer keeps wandering at a certain distance from his origin, his home, and his life and death. Living as a wanderer, every person seeks his or her home and gazes at their origin, life and death. According to Fisk's analysis, the circular formation of "wandering" is concretely expressed by means of the musical forms and tonalities in Schubert's music.

Fisk presents his argument that most of Schubert's pieces have a stable opening tonality, settled in the home key, but some of them do not. Taking Schubert's Sonata in C minor, D. 958, as an example, Fisk asserts that "the first response of the music to its own opening idea can be said to individuate a protagonist that is not at home in the opening key" (Fisk 2001, 272). The piece starts in the home key, but the Ab-major descending scale suddenly comes in, interrupting the tonic cadence. Fisk says that this is "in order to introduce in this secondary key a new motive that is more generative in some respects than the opening motive for the ensuing music" (272). A similar case can be seen in the first impromptu of D. 899. Although the home key is introduced clearly at the beginning, the opening G octave obstructs the sense of fixed tonality, producing an unsteady and ambiguous mood. Fisk says that the opening G is "imbuing the tonic region more with

the character of a scene of exile or imprisonment than of a potential haven” (272). Thus, the opening tonality is controlled by the complex sense of the wanderer’s exile.

Fisk describes not only the ambiguity of the opening tonality, but also the tonal dissociations in the closing section of the impromptu. Fisk says that motivic development in the Impromptus D. 899 is an important element for building a cyclic organization in this work, but the cyclic formation also results from tonal resolutions. For example, the closing tonality of the first impromptu D. 899 is inconclusive—although the tonality turns from minor to major at the end, its major/minor contrast is still unclear, leaving the feeling of minor mode. Fisk writes that “the modal ambiguity of this ending suggests the impossibility of any full tonal resolution for this music in its opening key” (273). Fisk states that “these dissociations remain in some respects unresolved at the ends of those opening movements” (273). He also says that the sense of dissociation is more intensified in the slow or middle movements. Thus, because of the appearances of unresolved tonalities through the work, the sense of homecoming or reaching home is often sustained until the final movement of the work. In other words, the obscurity of the tonality represents the wanderer’s search for home which is continued throughout the work. In this way, the music not only creates continuity and unity between the movements by expressing the whole story of the wanderer’s home-searching journey, but also portrays intricate sentiments of the wanderer who struggles with mental dissociations and who hopes to get home but cannot reach it.

Fisk puts forward Schubert’s Sonata in A major, D. 959, as a typical example of a Schubert piece in cyclic organization. Fisk says that “this music counterbalances its disjunctions with continual returns to its own generative motives” (Fisk 2001, 2). Fisk

continues to describe the cyclic characteristics of this sonata as follows:

Its opening rhythmic motives return in all of its movements; the finale ends by virtually quoting the beginning of its first movement; the Scherzo incorporates another virtual musical quotation, a downward rushing C#-minor scale recalling the wild central episode of its Andantino; and the Scherzo and the finale both return to secondary tonal regions especially stressed in the first two movements. On close examination, still more cyclic elements emerge, until virtually every passage in the sonata becomes implicated in processes spanning all four movements. (2)

In the A-major sonata, C-major and C#-minor sections appear alternately throughout the work. Fisk claims that C major represents the wanderer's dream, and treats C# minor as the dream's nightmarish opposite (he calls C# minor the "wanderer's key"). He says that these contrasting keys find their way to coalesce with each other and blend into the tonic key at the end, as if the wanderer finds his way to reach home. Fisk writes that "distinctive memories in the finale of the C-major and C#-minor music, the Fremdling's dream and his ensuing nightmare, become integrated with, and hence subordinated to, a lyrically possessed tonic reality. The separate tableaux are no longer so independent; instead they weave together to suggest a narrative of integration, of the finding of a home hospitable enough to be a haven for the protagonist's dreams and a refuge from his nightmares" (276). Schubert's use of cyclic elements and contrasting keys in the Sonata greatly typify the wanderer's path and his sentiments.

The other piece that Fisk includes in his study is Schubert's Moment Musical No.2 in A-flat major. He says that the piece does not have any thematic references to the Fremdling songs, unlike the "Wanderer" fantasy, but it contains the character of

wandering and significant elements that evoke that character. Fisk writes that because of the opening ambiguities of its meter, mode, and rhythmic genre, the second theme which comes in measure 18 works as the clarification or answer to that opening obscurity. Fisk writes that “because of its clarity, the new theme seems to embody something more real than the opening one, but the clarifications it brings come only at great cost. This new theme is unambiguously sad; and its key, F# minor, is remote enough from the opening Ab major to imbue it with a sense of loss or even exile” (Fisk 2001, 278). The opening Ab-major section might have a kind of dream-like quality as if the wanderer is returning to happy memories, but the appearance of the second theme is the moment when that vague dream is vanished, and the wanderer’s loneliness and despair comes back in reality.

The formal structure ABA’B’A” of the Moment Musical No. 2 also shows the influence of wandering. Fisk says that the alternating A and B sections are a Schubertian specialty that is used not only in this piece but also in other Schubert pieces, including his C-minor impromptu and C-minor sonata. The alternating A and B sections are just like the story of Schubert’s “My Dream,” where the wanderer’s returning home and exile happen in sequence. Fisk writes that Moment Musical No. 2 “corresponds with the story not only in its ABA’B’A” form but also in a stratified tonal plan that makes the F#-minor B sections into potential musical realizations of its scenes of exile. The violent beginning of the second B section mirrors the father’s violence from which the narrator of “Mein Traum” flees into his second exile; the F#-major epiphany that concludes that section corresponds equally aptly with the narrator’s admission, as if by magic, into the circle around the dead maiden’s tomb” (Fisk 2001, 280). Fisk continues that “this piece mirrors

the patterns of exile and homecoming in the story closely enough to corroborate the notion that the seemingly distinct personae generated by this piece and by the story can both be identified as revelatory self-projections of the actual person—Franz Schubert—who created them” (280).

As Fisk argues in his studies, the formal and tonal organization of Schubert’s music reflects Schubert’s own prose writing, “My Dream,” and his life. Like the protagonist of “My Dream” who keeps wandering after the second banishment, Schubert himself wanders during his life’s journey to seek for his “spiritual” home. It is not certain if the story described in “My Dream” corresponds to true events in Schubert’s life, but “Those episodes and their course—exile, failed homecoming, subsequent singing-in-exile, and final, death-haunted, transfigured homecoming—are the inventions (or, at the very least, the choices) of the same man who also chose, only months after writing them out, to base a revolutionary instrumental work on the song of an exile and who was later impelled to set not merely the first twelve but eventually all twenty-four songs of *Winterreise*’s exiled and death-obsessed protagonist” (Fisk 2001, 271). Fisk writes that “the supposition that, in the absence of corroborating outer fact, it mirrors an “inner reality” finds confirmation in Schubert’s subsequent quests, through his music, to alleviate his apparent sense of exile and his anticipation of early death. “Mein Traum,” in crystallizing an imaginary narrative of Schubert’s life, foretells the narrative journey on which he was soon to embark, probably without ever explicitly acknowledging it to himself, in his music” (271).

Rene Rusch's Analysis

Rene Rusch discusses Charles Fisk's interpretation of Schubert's Moments Musical in his article "Rethinking Conceptions of Unity" (2011). As I mentioned above, Fisk relates his analysis of the formal structure of Moment Musical No. 2 in A-flat major to the story of Schubert's autograph "My Dream" in his article "Returning Cycles." Fisk says that the five sections of Moment Musical No. 2 (ABA'B'A") correspond to the story of "My Dream," which delineates the five events in a wanderer's life journey: "home→exile→return home→return to exile→transfigured homecoming." Rusch praises Fisk's analysis in this way: "weaving biography and analysis, and past and present, into a rich variegated tapestry, Fisk provides a reading of the Moment Musical which enables us to experience a 'unity of consciousness' and 'new kinds of continuity'" (Rusch 2011, 60). Rusch also discusses an analysis by Allen Cadwallader and David Gagné of the same piece (which does not deal with the topic of wandering).² Their analysis treats the piece's ABABA form as "a three-part form that expands to five parts through the varied restatements of the B and A sections" (AB-AB-A), and those repetitions of alternate AB sections gives the piece its formal balance—unlike the unbalanced phrase groups in the middle A section, the phrase groups in the first and the last A sections are balanced with each other well. Also, while the first A section had cadenced in Db major, the final A section resolves to the tonic (Ab major) in measures 81–82—by sustaining its tonic resolution until the end of the piece, it creates tonal unity in the piece.

With analyses by Fisk and Cadwallader and Gagné as his supporting ideas, Rusch presents his own idea that hybrid-presented/avoided closures and juxtaposition of remote

² See Cadwallader and Gagné, *Analysis of Tonal Music*, 2011, pp. 281–295.

key areas in Schubert's music satisfy the taste of Romantic irony, and create a new kind of "conception of unity" in Schubert's music. For example, he claims that, in Moment Musical No. 2, the return of a F#-minor passage and the following sections could be treated as a coda (B-A), thus avoiding closure of the hybrid three-part ternary form (A-B-A). Rusch writes that Schubert's "use of tonality and 'experimental' approaches to musical form seem to resonate with the early German Romantics' concern with unity as it relates to both subjectivity and the work of art" (Rusch 2011, 61). Rusch claims that "early German Romantic irony" signifies an "aesthetic and philosophical demeanour that could permeate an entire work," and he lists the ironic elements in Moment Musical No. 2. In addition to the avoidance of closure that I mentioned above, Rusch says that the following elements in the piece enhance its ironic quality: Schubert's use of unbalanced antecedent/consequent phrases—extending the consequent phrase to nine measures (mm. 8–17); unexpected modulation to the subdominant at the end of the first A section (mm. 15–17, where the descending half steps in the bass Cb–Bb–Bbb–Ab lead the modulation from Ab major to Db major); the syntactical and enharmonic treatment of Gb major—F# minor—F# major through the piece. These ironic elements in Schubert's music not only detach themselves from the notion of traditional form and tonality, but also explore new conceptions of unity and continuity. While some scholars have argued that Schubert's music lacks coherence, Rusch provides us a way to understand the sudden key shifts and relations between remote keys, and also reveals the interconnections of Schubert's music which create tonal and formal unity.

Jeffrey Perry's Analysis

Jeffrey Perry's article "The Wanderer's Many Returns: Schubert's Variations Reconsidered" (2002) starts by defining 'wanderer' and 'tourist.' (See my Chapter 2, page 14, for the details.) While Perry recognizes the difference between these two types of traveler, he suggests that wandering and touring co-existed in Schubert's musical sensibility. Perry's study analyzes Schubert's variations through the concept of 'distance,' where the wanderer's departure and return are expressed through Schubert's formal innovations. Perry says that these innovations are "made in the service of a Romantic sensibility of distance, loss, memory, and regret; more specifically, in these works Schubert explores the topic of distance in new and intensely imaginative ways" (415).

His study of musical 'distance' is associated with the principle of sonata form. He claims that Schubert's variations are hybrids with sonata form, saying that "Schubert infuses variation form with salient characteristics of the sonata principle in a way that no other composer, including Beethoven, had done before." Perry also writes that "Schubert's variations not only take certain musical topics he inherited—those which express literal and metaphorical distance—and bend them to structural and expressive purposes with poetry, wit, and sophistication; they also bring about an integration of variation form and sonata principle that was to be of great relevance to subsequent composers" (Perry 2002, 379).

Perry provides an analysis of Schubert's "Trout" variations, focusing on the tonal and formal process that generates the elements of distance. He writes as follows;

It is in the sonata-form narrative of the "Trout" variations that we begin to perceive the role that the topic of travel, of distance and return, plays in shaping

the work. Variations 1 through 3 progressively distance the melody from its original registral and timbral home. The third variation, which places the melody as low (and thus as far away) as it can go, serves to tie off the first (tonic) group. Variation 4, in D minor, acts as a bridge theme, a shaking off of the thematic hegemony of the D major theme, while variation 5, although a harmonic departure, does the work of bridging the gap opened up by the distancing process of variations 1 through 3 and the new tonal and thematic departure of variation 4. The fifth variation is where Schubert steps out of the framework of 18th-century theme-and-variations form, allowing the sonata principle to assert its needs by having the second reprise signal the start of a developmental “tour of keys” which leads to the structural dominant of measure 127. (389)

While the musical return normally means a return of principal material in the tonic key, Schubert’s “Trout” not only uses a return “of the theme in its original key, mode, register and instrument,” but also shows a return of the original piano accompaniment of the 1817 *lied*. Perry says that “even as he signals structural closure, then, Schubert draws our attention to the distance between the song and the quintet movement by identifying the latter as a transcription, an echo, a simulacrum, of the former. If...we are returning home at this point, it is not quite the home we remember; perhaps, too, we are returning home in spirit, not in body” (390).

The topics of distance, departure and return are crucial themes in musical form, discussed especially in the study of sonata form and *Lied*. In Schubert’s music, Perry says, the musical distances are expressed in relation to romantic sensibilities such as loss and memory, as well as disappointment and ambivalence, but those distances are also a symbol of “generalized nostalgia for an idealized past life—whether childhood, the season of one’s first love or heartbreak” (Perry 2002, 391). Schubert explores the musical aspects of distance, such as distance from the home key or from the home register, as

well as the distance between the original *lied* and the instrumental music, in order to represent the romantic sense of distance from home, from past memories, and the accompanying sense of remorse.

William Kinderman's Analysis

In "Wandering Archetypes in Schubert's Instrumental Music," William Kinderman discusses the duality of inward imagination and outward perception in Schubert's music (1997). Kinderman writes that paintings by Schubert's contemporary, Casper David Friedrich, show the wanderer archetype in a mysterious and impressionistic landscape. Friedrich's paintings, such as *The Monk at the Sea* and *The Wanderer Above the Mists*, present the "contrast between an objective natural environment independent of humanity, and the viewpoint of the individual human subject" (209). Like the wanderer archetype drawn in Friedrich's paintings, Schubert's song cycle *Winterreise*, for example, shows the correspondence between "the inward sensibility of the wanderer and outward natural objects such as the frozen stream, cold wind, circling crow or howling dogs" (209).

Kinderman says that "Schubert typically underscores this experiential duality through a combination of thematic and modal contrast often coupled with abrupt modulation" (Kinderman 1997, 209). As I mentioned in chapter 2, Kinderman gives an example of this duality in Schubert's *Winterreise*, the shift of the minor mode representing the darkness and dismay of the wanderer to the major mode representing dreams, visions, or bright recollections. Similar musical contrasts are also seen in Schubert's other songs and instrumental works. For example, Kinderman writes that the slow movement in the String Quintet in C major, D. 956 is a good example of a piece in

which Schubert applies the contrast of major/minor modes. Kinderman says that, in the Adagio of the String Quintet, “the cadential tonic note E that was gently affirmed in the final measures of the opening section is suddenly transformed into a unison trill in all the instruments, becoming a leading note to F-minor, with the pivotal destabilizing shift underscored by the crescendo to fortissimo and by ensuing syncopations and other textural means” (213).

Schubert uses not only tonal and modal shifts to represent the contrast between inward and outward motion, but also textural and registral differences. Schubert’s “Dass sie hier gewesen,” D. 775 is an example of this. Kinderman says that, in this piece, “the memory of the beloved is confined to a single melodic phrase in the major, whereas the remaining music associated with present reality is more expansive in its harmony and register” (Kinderman 1997, 211–212).

As a more radical example of Schubert’s use of contrast, Kinderman presents an analysis of the Sonata in A major, D. 959. Kinderman writes about the musical contrast between sections in the ternary form of the slow movement, where the outer sections in a mood of “melancholic contemplation” contrast with the middle section’s “chaotic violence.” Kinderman writes that “the outer sections of this ternary musical form thus embody the reflective mood of the lyrical subject, but the music of the contrasting middle section annihilates this frame of reference. After the descending sequences of amorphous passagework reach C minor, the most remote of key relations from the tonic, the music continues to build relentlessly, exploiting the most extreme registers and a structural use of trills as a means of sustaining the tension of the musical lines at fixed levels of pitch” (218). Kinderman also points out allusions among the movements of the work: “These

include moments of transition from one movement to the next, as when Schubert reharmonizes the repeated A closing the opening Allegro as the third degree of F# minor to begin the Andantino, or when he anticipates paradoxically the joyous arpeggios in the low register” (219).

As Schubert describes the contrast between “love and pain” in his own allegorical tale, contrasting tonal, harmonic, and formal sections in Schubert’s music represent the wanderer’s dilemma, and those contrasts conflict but co-exist together in his works illustrating the wanderer archetype.

Peter Pesic’s Analysis

Peter Pesic demonstrates that the wanderer’s conflict between pain and love in Schubert’s tale is represented by the dissonant sounds in Schubert’s music. According to him, the “rich mixture of pain and pleasure gives a heartbreaking quality to Schubert’s music, especially to those passages one might expect to be least dissonant because they are the long-awaited moments of return. A highly dissonant chord often serves to intensify a moment of return and climactic reconciliation, as at the end of the first movement in the Bb sonata” (Pesic 1999, 138). Reflecting the protagonist’s life in “My Dream,” in which mental conflict continued for long years, but dissolved in the reconciliation with his father at the end of the tale, the dissonant sound in Schubert’s music shows the “prolonged preparation for the ecstasy of ‘eternal bliss compressed into a single moment’” (Pesic 1999, 138).

Schubert’s tale and the music resonate to each other in the tonal process. Pesic writes that the both the tale and Bb sonata begin with “a ‘feast’ of untroubled ‘family

music’, the tonic and its closely related tonal degrees.” Pesic continues that “the complications in the dream begin with the ‘sadness’ of the dreamer; likewise, in the sonata an ambiguous chord appears (bVI), not securely related to the tonic and dominant. The dreamer’s divergence alters or disrupts the simple beginning and draws it to wander. This wandering extends more widely until it reaches a critical estrangement from its origin, represented by the death of the mother in Schubert’s tale. The father’s angry blows show that the wanderer is unreconciled with his home. Similarly, the ‘home’ key is no longer a haven but the locus of the most dissonant relations. In the development, Schubert redoubles the relation bVI to bvi/bVI, a double banishment that then circles back to the home key, gaining the tonic through the most distanced separation” (Pesic 1999, 138).

Pesic states that Schubert also uses bVI in the G-major Piano Sonata. As in the Bb sonata, Schubert uses what Pesic calls the “circle of sixths” around bVI in the G-major sonata; G→Eb→B=Cb→G=Abb (the progression in the fourth movement, mm. 154–160). Schubert’s repeated use of the bVI and progressing through the circle of sixths coincides with the events in “My Dream”; doubled deaths, banishments, and returns. These doubling events are expressed by returning the second tonal group (by passing two tonal stages) in a way back to the tonic through the circle of sixths; I→bVI→bVI/bVI→I.

Pesic also provides an interesting observation on “the two little words”—“Ja” (yes) and “Nein” (no)—used in Schubert’s song “Der Neugierige” from his cycle *Die Schöne Müllerin*. These two words are used in mm. 33–35 of the song, where Schubert sets “Ja” to a V⁶ chord and “Nein” to a bVI⁶ chord. Compared to the word “Ja” on the consonant dominant chord, the word “Nein” is placed on the dissonant bVI, expressing the wanderer’s complex feeling at the subtle negation. Also, because the distance of the two

notes from V6-bVI6, F#-G, is only a half-step, the close relation between them represents the ambiguity that makes the wanderer's heart perturbed and wavering. This half-step ascending relation is also seen near the end of the cycle. Pesic writes that "the despairing miller uses $i \rightarrow bII$ to ask the brook if he knows what love can do ("Der Müller und der Bach," m. 67), implying by this harmonic shift a far darker answer than he earlier expected when invoking $V \rightarrow bVI$ " (Pesic 1999, 144).

John Bell Young's Analysis

Unlike Fisk, Young does not think that real experiences in Schubert's life, especially the circumstances of his disease, are fully reflected in his music. However, Young provides analyses of the Impromptus D. 899, the Sonata in C minor, D. 958, and the Wanderer Fantasy, influenced by his view of the correlation between the music and the image of the wanderer. As I mentioned in my introduction, Young states that the influence of the topic of *Winterreise* (the wanderer marching toward his death) on Schubert's Impromptus D. 899 is obviously shown by elements in the music. For example, the drumroll-like rhythm (long-long-short-short-short-long) in the B section of Impromptu No. 2 in E-flat major is the representation of a death summons which leads the wanderer to his fate. Young also says that the opening four notes in the melody of Impromptu No. 3 in G-flat major are in the dactyl rhythm, which expresses the wanderer's alienation and longing since it is used in the "Wanderer" fantasy and its source *lied* "Der Wanderer" (Young 2009, 100).

The frequent occurrence of dactyl rhythms in the Wanderer fantasy acts as the thematic unifier of all movements. Also, similar to Fisk's argument that C# minor, or C#,

is the key of the wanderer, Young also mentions the importance of C#; in the Wanderer Fantasy, the opening melody ascends to C# in the third bar. Young writes that these opening measures remind us of Schubert's use of C# in the original lied "Der Wanderer," where the C# is used for "the demarcation point for the word Fremdling amid the words "Ich bin ein Fremdling überall (I am a stranger everywhere)" (Young 2009, 81). In the C-minor Sonata, Schubert also uses motives to represent the image of the wanderer. For instance, in the Adagio, the second movement, measures 11 and 12 can be viewed as a "weeping motive," since their progression from Db major to a minor subdominant chord is similarly used in a phrase in the song "Gefror'ne Tränen (Frozen Tears)" from his cycle *Winterreise*.

Richard Cohn's Analysis

Unlike the analyses by other scholars that I introduced in this chapter, Richard Cohn's article "As Wonderful as Star Clusters: Instruments for Gazing at Tonality in Schubert" does not relate his analysis directly to the portrayal of the "wanderer," but instead focuses on Schubert's unique harmonic network that unifies the remote keys/chords. At the beginning, Cohn quotes Donald Francis Tovey's metaphorical sentence that describes Schubert's harmonies (Cohn 1999, 213). Tovey writes in his 1928 essay that "Schubert's tonality is as wonderful as star clusters, and a verbal description of it as dull as a volume of astronomical tables." Cohn explains that there are two contrasting images that describe Schubert's harmonies. He writes that "the traditional metaphorical source for tonal relations is the solar system, where positions are determined relative to a central unifying element." He also writes that "A star cluster (in

Tovey's sentence) evokes a network of elements and relations, none of which hold prior privileged status" (Cohn 1999, 213). These contrasting metaphors both describe Schubertian harmonies, comparing them to a formation of the universe, but have totally different viewpoints. The former describes Schubert's harmonies as the solar system moving around its center, the sun, in order to imply them progressing around the certain tonal center. In contrast, the latter represents Schubert's harmonies as a number of shining stars in the sky, saying that Schubertian harmonies are like these stars, holding no center and no prior privileged status, but connected in some sort of network. Cohn concentrates on describing this "network" through analysis in his article, using maps and tables. He writes that the "network" is created in Schubert's music by three types of harmonies; 1) adjacent harmony, 2) modally matched harmony, 3) polar harmony. Also, Cohn introduces four types of harmonic transformations actively used in Schubert's music; 1) modal mixture, 2) root relation by third, 3) motion through the enharmonic seam, 4) equal division of the octave. His analysis of Schubertian "networks" reveals the unique relationships between the harmonies, and the unity created by those networks.

His analysis of Schubert's Bb-major Piano Sonata, D. 960, shows the interesting polar relation between its tonic and F# minor in the exposition. By analyzing the relation through the view of voice-leading efficiency and enharmonic equivalence, we can understand the relation of these two chords as polar keys, specifically what Cohn terms the "hexatonic pole" relationship. In the exposition, Bb major modulates to F# minor via a Gb-major chord; If we analyze this three-chord progression by its semitonal displacements, not by the diatonic relations, we can notice that the relation between Bb major and F# minor is understood by the double semitonal displacement (Bb-major to

Gb-major: D→Db, F→Gb) followed by the thematic displacement (Gb major to F# minor: Bb→A).

Cohn writes that “My thesis....is that efficient voice leading, emphasizing semitonal displacement, furnishes a context in which to understand nineteenth-century triadic progressions that are not adequately reconcilable to diatonic tonality” (Cohn 1999, 231). He also continues that “the methodological argument I wish to advance here, though, is served by focusing not on the distinction between these two methods of construing triadic space, but rather on a point of similarity between them: diatonic tonality and voice-leading proximity are equivalently *systematic* ways of interpreting harmonic relations” (231). Cohn provides a new systematic way to comprehend the harmonic modulations, and in this way discloses the “network” behind the music, which explains the smoothness of the progression and unity of the work. This way to approach harmonic relations is not a standard diatonic analysis, but it gives us a new way to understand Schubertian harmonic progressions, by revealing the hidden connections between the notes and harmonies, like the relations between the star clusters in the sky.

Cohn reveals networks that connect remote harmonies without any center or central key but creates a close bond between the chords. My analysis will also suggest a way to understand the connection and unity of the harmony through *Tonnetz* graphs, but my graphs will highlight the “center” which represents the “home” of a wanderer, that is placed at a central place within a circular wandering motion.

Michael Siciliano’s Analysis

Other than Cohn, among theorists whose studies reveal networks of chord

transformations without any central key, Michael Siciliano also gives a graphical representation of chord transformations which are not able to be explained by the traditional harmonic structure. In his article “Two Neo-Riemannian Analyses” (2005), he presents analyses of two of Schubert’s songs, “Der Jüngling und der Tod” D. 545 and “Trost” D. 523. The common feature between these two songs is that the song starts and ends in different keys. As Siciliano writes in his article, the lack of a single governing key creates a challenge in these pieces; the challenge is, without a governing key, “how to make the various parts of the piece sound as though they belong together” (Siciliano 2005, 92). Siciliano shows us how the cycle created by Neo-Riemannian relations reveals the harmonic connections established in these pieces which lack the domination of a single tonic. For the song “Der Jüngling und der Tod,” starting in C# minor and ending in Bb major, he explains this harmonic move by using the RP cycle, a chain of alternating R (relative) and P (parallel) relations. With the RP relations, even though the song begins in one key and ends in a different one, the different chords through the piece can belong to one unified cycle. Similarly, Siciliano also shows the LRP cycle of the song “Trost.” The chord transformation through that 17-measure short song, $G\#m \rightarrow Bm \rightarrow Bm \rightarrow Gm \rightarrow Em \rightarrow EM$, can be explained by the LRP cycle (hexagonal relation), which is the alternating L (leading-tone), R (relative) and P (parallel) exchanges, and all the triads in this cycle share the same pitch, B. Thus, the feeling of belonging together and the feeling of completion at the end of each of these songs are understood by the Neo-Riemannian operations hidden behind the music. It is interesting that the LRP progression in “Trost” is circular, because most of the progressions I will discuss later in my dissertation are also circular. The progression in “Trost,” however, is different from those in the selected piano

works of Schubert in two ways: first, the progressions I will discuss later typically do not feature a simple circular motion on the *Tonnetz*, but include other paths which embellish the circle. Secondly, the progression in “Trost” does not complete itself, as will the progressions in two of the works that I will discuss—the Sonata in C Minor and the “Wanderer” Fantasy.

Similar to Siciliano’s chain using the LRP cycle, Tymoczko in “Three Conceptions of Musical Distance” shows the circular relationship of diatonic fifths and thirds (Tymoczko’s graph does not associate with any particular piece, though.) Through the article, he compares three types of musical distances (based on voice-leading, acoustics and Fourier transform) through different geometrical perspectives. The musical distances vary through different ways of measurement and perspectives, and Tymoczko claims that we should be careful about “which model is appropriate for which music-theoretical purpose.” Tymoczko challenges the idea that geometrical distances on the *Tonnetz* accurately reflect voice-leading distances (Tymoczko 2009, 14). However, I choose to use the *Tonnetz* distances because they effectively represent the notion of circular wandering in the pieces I have chosen to analyze.

Theodor Adorno’s Analysis

As I mentioned in Chapter 2, Adorno provides a philosophical analysis of Schubert’s music, focusing on “Schubert’s landscape,” the structure of the wanderer’s journey toward his death. As he states that “the full and decisive dignity of the concept of the wanderer has never been discussed in terms of the structure of Schubert’s works” (Adorno 2005 (originally published in German in 1982), 10), his analysis was one of the

earliest studies of Schubert's music representing essential elements of the wanderer. Taking the cyclical layout of Schubert's songs and instrumental music, he argues that those circulations represent the wanderer's life itself, and he says their circularity "lies in the timeless path between birth and death" (10).

Schubert's music is repetitive and recursive. Adorno writes that "Schubert's themes wander just like the miller does, or he whose beloved abandoned him to the winter" (Adorno 2005, 10). He describes Schubert's music as in the form of an invocation of what has already appeared. Adorno writes that "this basic (of Schubert's forms) *a priori* completely took over the Schubertian sonata: here, harmonic shifts replace developing transitions like changes in lighting exposing a new part in the landscape, that itself entails as little development as any earlier part; and here too, in development sections, motivic [segmentation]³ of the themes—exploiting for the sake of dynamic sparks their every little element—is renounced, and the recurrent themes are disclosed progressively; here too he takes themes from earlier that are encountered but not consigned to the past; and the sonata covers all this like a thin, rustling husk spread over the growing crystals and ready to shatter" (Adorno 2005, 11). Such recursive music represents the landscape of death, or the path of the wanderer's journey, where it has a center, and every point of the wanderer's path is equally close to that center. Adorno continues that "those themes know of no history, but only shifts in perspective: the only way they change is through a change of light, and this explains Schubert's inclination to use the same theme two or three times in different works, and different ways" (Adorno 2005, 10). He also says that "the

³ Jonathan Dunsby and Beate Perry translate Adorno's German word "zergliedern" as "unpicking." I have substituted "segmentation" as a more-easily grasped alternative for it. See Dunsby and Perry, "Schubert (1928)", p. 11.

wanderer encounters these repeated features in new lighting—they are timeless and appear to be disconnected, isolated” (10).

Schubert’s themes are recursive, but each return of the theme is different from the others through a “change of lighting.” Adorno compares Schubert’s themes with the “potpourri,” a musical form that was popular in the 19th century. In potpourri, the different themes or sections are juxtaposed without any strong connections between them. Adorno writes that “the world of the potpourri...guarantees Schubert’s themes a new lease of life. The potpourri condenses those features of a work which the downfall of subjective unity has dispersed within it, forming a new, unified entity which, even if admittedly unjustified in itself, can nevertheless show how unique such features are in comparison” (Adorno 2005, 9).

As he writes that every point (of the landscape) is equally close to the center, every point of one’s life is equally close to one’s death and birth. In one’s life, death is always equally close to oneself. This is the wanderer’s landscape of death. This landscape of death creates the circularity of human life, and Schubert’s music is a representation of it: the circularity which is continued between life and death forever. Adorno concludes his article with these sentences; “Schubert’s music brings tears to our eyes, without any questioning of the soul: this is how stark and real is the way that the music strikes us. We cry without knowing why, because we are not yet what this music promises for us. We cry, knowing in untold happiness, that this music is as it is in the promise of what one day we ourselves will be” (Adorno 2005, 14). It seems that Schubert’s music shows us the reality of our lives and the essence of human life and death. Like Jonathan Dunsby writes in his article “Adorno's Image of Schubert’s *Wanderer* Fantasy Multiplied by Ten”; “for

Schubert, death is a “reality” through with...we have no choice but to live” (Dunsby 2005, 42), Schubert conveys a reality in which our life and death are connected to each other in circulation.

Through this chapter, I have discussed analyses by other scholars whose studies show Schubert’s way of depicting “wandering” in his music, using tonal, harmonic and formal devices. Their analyses reveal elements of wandering in Schubert’s music as well as the correspondence between Schubert’s allegorical tale “My Dream” and his music (except Cohn’s analysis, which focuses on the network connections between the polar harmonies, without discussing the elements of wandering, and Siciliano’s analysis of Neo-Riemannian operations which reveal unified cycles behind the music). Some of them emphasize the image of the wanderer moving in a circle around a central point, which signifies the wanderer’s birth and death. My analyses will apply that image in a new way to the key and chord progressions of Schubert’s music. Before moving into the next chapter, I would like to explain briefly the direction of my analysis, and how it differs from that of other scholars.

In the following chapters (chapter 4 through 8), I will demonstrate my harmonic and melodic analyses of different Schubert pieces, using Neo-Riemannian graphs as well as Schenkerian graphs. These analyses and graphs enable me to comprehend the essence of “wandering” that Schubert depicts in his music. My analyses differ from those of other theorists in the following ways:

1. Unlike previous theorists who relate their analysis to the concept of

- “wandering,” I will use Neo-Riemannian graphs (map out chord and key progressions on a *Tonnetz*) to comprehend Schubert’s concept of circular wandering geometrically, and establish a way to grasp Schubert’s music visually.
2. While much of the Neo-Riemannian literature focuses on the analysis of isolated “phrases” or “sections” in Schubert’s music, my analysis will demonstrate the harmonic/melodic structure of the whole piece/whole work, showing how the smaller sections fit within the whole.
 3. In addition to my Neo-Riemannian graphs, I also would like to use Schenkerian graphs for certain pieces, so that my analysis comprehends the structure and the unity of Schubert’s music through both horizontal and vertical viewpoints.

As I indicated in Chapter 1, I will analyze the following works by Schubert: Impromptus, D. 899; Moments Musical, D. 780; Sonata in C minor, D. 958; and “Wanderer” Fantasy, D. 760. Each work is a set of different pieces, and all of them belong to Schubert’s late piano works. The main reason I chose these pieces is that it seems to me Schubert’s late works are heavily tinged with his concepts of wandering between life and death.

I want to note here that the Neo-Riemannian graphs I will show in the following chapters use the traditional plane *Tonnetz* (two-dimensional), not the Torus (three-dimensional.) By using the plane *Tonnetz*, it makes it possible for me to differentiate between enharmonic pitches or chords, such as C# and Db, E# and F, in Schubert’s music. In the article “Some Aspects of Three-Dimensional *Tonnetze*,” (1998) Edward Gollin writes about the difference between the two-dimensional and three-dimensional

Tonnetz graphs in terms of their manipulations of equally-tempered tones. He says, “if one assumes an arrangement of equally-tempered pitch classes (rather than just-intoned pitches), the *Tonnetz* would be situated not in an infinite Cartesian plane, but on the closed, unbounded surface of a torus” (Gollin 1998, 196). In my analyses, I would like to use the plane *Tonnetz* rather than the equally-tempered one, even though I am discussing piano music, in order to treat the enharmonic tones and harmonies as different entities having different meanings. For instance, in Schubert’s Impromptu D. 899-No. 2, the transitional harmony between A and B sections, the Gb-major chord at measure 250, functions as an ending chord of the A section, but at the same time as a dominant (enharmonically treated Gb=F# major) leading to the B minor of the next section. Even though they are enharmonically the same, their functions are different. I use two-dimensional graphs to visually emphasize that kind of difference between the enharmonic chords.

In Chapter 4, I will use Schenkerian graphs to help understand Schubert’s harmonic progressions from the horizontal perspective, especially for the sections where the vertical viewpoint is not enough to explain the transformation. Also, the other reason for using Schenkerian graphs is to explore the different possible ways to understand the unity of each work. While my Neo-Riemannian graphs are more effective in demonstrating unity in progressions from chord to chord, Schenkerian graphs show a unity of linear progression that connects chords. Also, their central purposes are slightly different—while the Neo-Riemannian graphs makes it possible to visually grasp the distance between the chords (either remote or close), the purpose of Schenkerian graphs is to visualize the different tones and parts of the piece as structured by one single skeleton. I

would like to use both kinds of graphs in order to explore different perspectives that the graphs provide for us.

In Chapter 2, I discussed the circular formation of human life and death. In Adorno's description of the wanderer's journey, walking around a path equidistant from the center, every step and every moment of one's life is equally close to death. That means, life proceeds toward death, but death also itself leads to life. In his allegorical tale "My Dream," Schubert describes the wanderer who struggles between love and pain but seeks for the hope of reconciliation. Also, in his poem "My Prayer," Schubert shows his hope for rebirth, through the dismay in the depth of his heart. Schubert portrays "death beyond life" and "life beyond death," in his tale and poems. Such a cycle between life and death is the configuration that represents the wanderer's journey and human life in general. How is this circularity, the essence of wandering, portrayed in Schubert's music? My analyses in the following chapters provide a geometrical and visual representation of Schubert's concept of wandering, the circular formation of the human soul.

CHAPTER IV

IMPROMPTUS, D. 899 (1827)

In this chapter, I would like to present my analyses of Schubert's *Impromptus*, D. 899, which were composed around 1827. Charles Fisk describes the publication of this work: "Schubert wrote out the four pieces that we know as the opus 90 impromptus in a single manuscript and first submitted them for publication in this form. Karl Haslinger initially published just the first two, the C minor and the Eb major, late in 1827, himself providing the title for them. Only thirty years later were the other two pieces from the manuscript incorporated into a new edition of opus 90 by Karl's son Tobias, the fourth in its original Ab-major, but the third in this...levitation from Gb to G" (Fisk 2001, 115). As I mentioned in chapter 1, this change of key of the third impromptu from Gb to G major was to make the piece less difficult for amateur players, but it was soon published again in the original Gb major. This piece is Schubert's only instrumental work in Gb major, a key in which Mozart, Haydn and Beethoven never wrote. I will say more about the special nature of this key later.

Diagram 1 on the next page shows the opening and closing keys of each piece (Impromptus Nos. 1–4) in D. 899 and their relationships. As the diagram shows, the opening and closing keys of each piece are in a parallel relation. (No. 3 is an exception, since the piece starts and ends in the same key, Gb major.) Also, the four pieces are connected by third relationships; that is, C to Eb between Nos. 1 and 2, Eb to Gb between No. 2 and No. 3, and Ab to C between No. 4 and No. 1. (There is no third relationship occurring between Gb Major of No. 3 and Ab minor of No. 4.) The opening

key of No. 1, C minor, is the relative minor of Eb Major, the opening key of No. 2. And, the closing key of No. 2, Eb minor, and the opening/closing key of No. 3, Gb Major, are in a relative major/minor relationship. These harmonic relationships create a close bond between the pieces, and convince us of the fact that Schubert wrote these pieces as a set.

Diagram 1: Tonal Relation between the Movements (Impromptus D. 899)

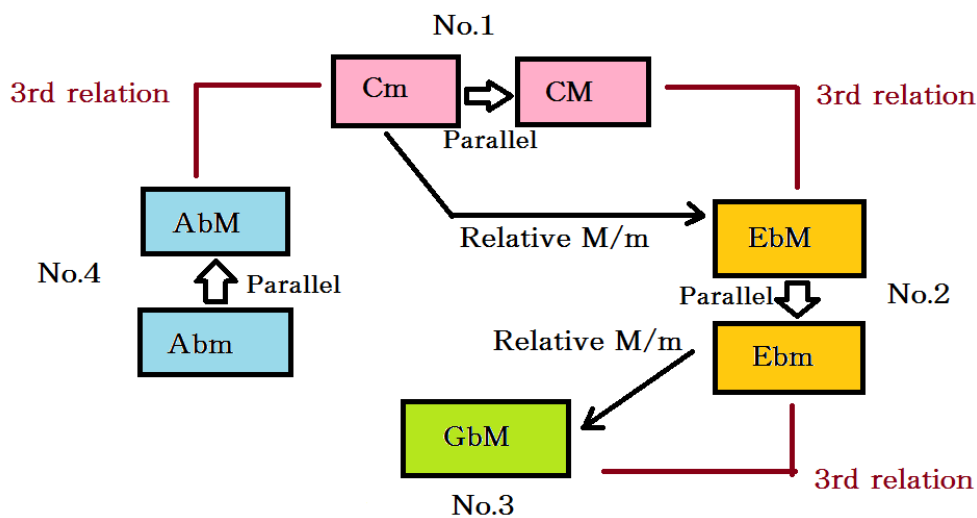

Fisk discusses the harmonic links between these impromptus, especially focusing on the linking of the ending of the Eb major impromptu to the beginning of the Gb-major impromptu. As mentioned before, the choice of Gb major for the third impromptu was rare among Schubert’s pieces. This choice was probably to make a connection to the ending of the preceding impromptu in Eb minor. Fisk writes that “whether or not the second impromptu is the first instrumental piece in a major key ever to end in minor, it is

surely the first well-known one to do so. Its tonal course, its way of being in its key, is therefore just as extraordinary for its time as is the key itself of the third impromptu. Because of the Eb-minor ending of the second impromptu, the Gb major of the third arises from its own relative minor, a source that it immediately acknowledges by returning to an Eb-minor triad in its first harmonic move” (Fisk 2001, 115–117). In addition to the smooth connection between the relative minor/major modes of the second and third impromptus, the opening I-vi (Gb major—Eb minor) harmonic progression as well as the Eb-minor middle section of the third impromptu call the ending harmony of the second impromptu to mind, reinforcing the alliance between the two movements.

The links between the second and third impromptus are also cultivated by sharing the same harmonic and melodic segments. Fisk discusses the pertinent segments as follows (the scores are provided on page 69, Examples 4.1 & 4.2);

The segment in question first occurs in measures 37 and 38 of the second impromptu, in which a melodic fall from 4 to 3 in Gb major is supported by the harmonic progression V4/3-I, while an Ebb appoggiatura in the tenor register strains within the dominant harmony. Essentially the same music reappears in measures 54 and 55 of the third impromptu, to conclude the transition from its B section back to its opening theme. Here the dominant seventh comes in first rather than second inversion, but its bass still leads by step to a Gb-major tonic triad in root position. The melody falls once again from 4 to 3, and the same Ebb wells up within the dominant harmony. Playing these two segments several times, one after the other, makes their similarity both audible and palpable. In both, melody and bass occupy the same registers, both moving fundamentally by step while triplets fill in the octave below the controlling melodic register of the right hand. In both, the Ebb to Db sigh, the most expressively distinctive gesture of the passage, brings the same fingers to the same pitches. (Fisk 2001, 39–41)

Example 4.1: Impromptu in E-flat major, D. 899-No. 2, mm. 37–40

Example 4.2: Impromptu in G-flat major, D. 899-No. 3, mm. 53–56

Thus, the use of relative keys and frequent use of Eb-minor harmony in the third impromptu, as well as the common melodic and harmonic segments and textures between the two movements, strengthens the bond. The texts of Schubert's song-cycle *Winterreise* give us a way to interpret the returning passages in the impromptu. The contrast of major/minor modes, which I discussed in chapter 3, is seen in both *Winterreise* and the impromptu. Fisk writes that "in the tonally extraordinary Eb-major Impromptu, the major mode is threatened by the minor and finally succumbs to it. In the *Winterreise* songs, which are predominantly in the minor, the major mode is associated with texts

about fading memories, dreams, and illusions. The dramatized subversion of the major in the Eb-major Impromptu especially invites such associations. The Gb major of the passage under consideration comes in response to the first turn to Eb minor and the subsequent cadence in that key, as if to avert the threat that the minor poses, however gently at first. In the Gb-major Impromptu, Eb minor persists as a troubling presence, especially in its agitated B section. The return of the passage from the preceding impromptu signals the final quieting of that troubled music, an ultimate overcoming of the Eb minor threat” (Fisk 2001, 42). By treating the contrast of minor/major modes as a threat to the wanderer and his recovery or relief from that threat, these two impromptus are more bound as a set.

Moreover, Cb-major harmony in the third impromptu works as a mediation between the Eb and Gb modes of the two impromptus. As the subdominant chord of the Gb major, this harmony first appears on the downbeat of measure 7 (the score of this section is attached on the next page, Example 4.3). Fisk writes that “the subdominant occurs for the first time in the third impromptu at a focal moment in the opening period: not only does it come at the midpoint of the consequent and on a downbeat in the midst of heightened activity, it also immediately follows Eb minor’s dominant, as if Eb minor were yielding to it. Because this Cb major triad initially averts a possible extension of Eb minor through this dominant, it enters the Gb major Impromptu potentially as an agent of recovery from the Eb minor crisis of the Eb major impromptu’s ending and from the agitated B minor music implicated in that crisis” (Fisk 2001, 117–118). Thus, the appearance of the Cb-major harmony in the opening section of the third impromptu acts as the bridge from Eb minor to Gb major. Similarly, the harmonic shift from Eb minor to

Cb major also appears in the middle section of the third impromptu at measure 32, implying a shadow of the progression in the opening section.

Example 4.3: Impromptu in G-flat major, D. 899-No. 3, mm. 5–8

Finally, although the Cb-major harmony does not appear in the second impromptu, its middle section in B minor (which is enharmonically treated as Cb minor, the parallel key of Cb major) builds a link between the two pieces. In addition, the recurrence of a B-minor passage in the coda of the third impromptu reminds us of the middle section of the second impromptu, linking the movements. Fisk writes that “the concluding phrase (of the coda) thus reinforces the impression that the recurrence of B minor in this coda links the B-minor episodes of the second impromptu to the Cb-major passages, both climactic and restful, of the third. It becomes plausible to interpret the Cb major that, along with Eb minor, so determines the tonal ambience of the third impromptu as specifically recalling

the driven Cb minor that so strongly reinforces the ultimate minor coloration of the second” (Fisk 2001, 118).

Fisk has argued that the Cb-major (or minor) harmonies form one of the main links between the second and third impromptus. Through my own analysis of these four pieces of D. 899, using his idea as a reference, I noticed that there is an important common pair of pitches (or pair of key areas) used in all four, what I call the “Cb-Bb” motive. In the first impromptu, the Cb and Bb appear as the two key areas presented in the middle section; Cb major from measure 51 and Bb major from measure 134 (see graph 4.1-A on page 77). In the second impromptu, the transformation from Eb minor to B minor (as the piece moves from the A-section to the B-section in mm. 82–83) involves these two pitches (Bb/A#→B(=Cb)) in the soprano. Similarly, the modulation from Eb minor to Eb major through measures 165–169 involves these two pitches in the soprano (Cb-Bb) (the scores of these sections are provided on pages 73 and 74, Examples 4.4 & 4.5; also, see graphs 4.2-A and 4.2-B on page 81 as a reference). In the third impromptu, the transition from Eb to Gb in measures 54–55 (where the B-section returns to the A-section) involves these two pitches in the top melody line (Cb-Bb) (the score of this section is attached on page 69, Example 4.2). Finally, in the fourth impromptu, the pitches Cb and Bb appear as the first two structural pitches at the very beginning of the piece (see graph 4.4-B on page 88). So, in all four of these pieces, the pair of pitches (or keys) “Cb-Bb” is used either for important key areas or as important voices supporting key transformations. This suggests to me that Cb and Bb are crucial pitches that unify all four of these pieces. Cb and Bb are used not only to create unity over the whole set but also to complete the third-relation cycle between the four pieces that I mentioned at the beginning of this chapter. Look at

the diagram on page 74 (Diagram 1-A). At the beginning of this chapter, I wrote that the opening/ending keys of these four pieces are in third relations to one another, with the sole exception of No. 3 (Gb) and No. 4 (Ab). However, the two pitches Cb and Bb complete the third-relation system, if we place them between the third and the fourth impromptu on the diagram; the tonic pitch Gb of the third impromptu is in a third relation to Bb, and Ab of the fourth is in a third relation to Cb. So, the pitches Cb and Bb act as a bridge creating a link between the third and fourth impromptu, and also as important motivic pitches unifying all four movements of this work. Fisk's argument suggests the significance of Cb-major harmony which binds the second and third impromptu. By emphasizing the Cb and Bb as a pair, as I indicated above, we discover that this pair of pitches is shared by all the movements, marking these four pieces as a cycle.

Example 4.4: Impromptu in E-flat major, D.899-No. 2, mm. 77–88

Bb/A# → B(=Cb)

Example 4.5: Impromptu in E-flat major, D. 899-No. 2, mm. 161–170

Diagram 1-A: Updated Tonal Relation (Impromptus D. 899)

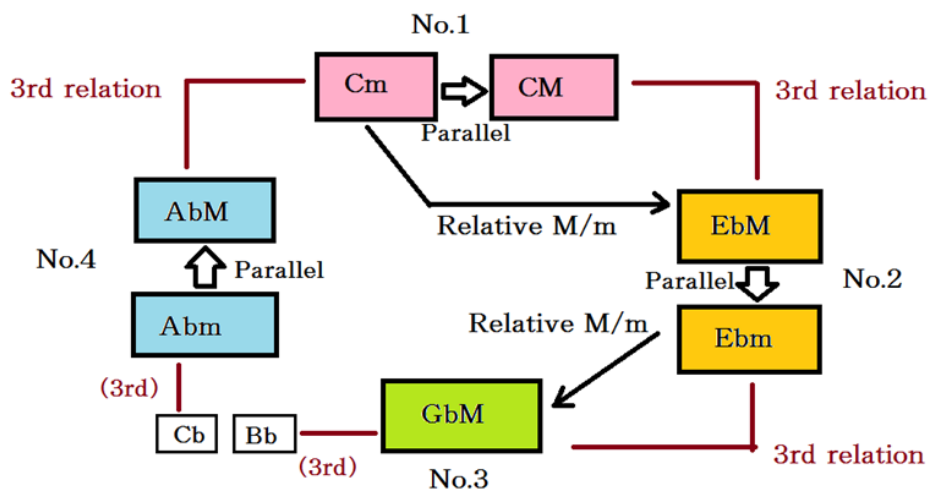

We have discussed how the second and third impromptus are in close association with each other in their tonal and harmonic processes. Similarly, Fisk also suggests linkages between the other impromptus. For example, he says that the melodic descent F-

Eb-Cb-Ab in measure 83 of the third impromptu anticipates the opening descending Ab-minor triad of the fourth impromptu. He also mentions how the opening Ab minor modulates to Ab major in the fourth impromptu and how this tonal process reminds us of the keys that are stressed in the earlier impromptus: “this last impromptu reaches and confirms its Ab major only after tonal digressions recalling not only the Cb major so prominent in the third impromptu but also the Cb/B minor so prominent in the second” (Fisk 2001, 123). He continues: “first the Cb major so highlighted in the third impromptu; then the B minor of the middle section of the second. The arrival in Ab major extends these recollections back another step: it is the key of the B section of the first impromptu. Unlike the Cb major and minor left on the horizon of awareness after the third impromptu’s coda, however, this Ab major is a remote memory. Many will be tempted to deny it any significance because the link is so unlikely to be heard, but in the mid-nineteenth century, and even well into the twentieth, most music lovers came to know opus 90 not simply by listening to it but also by playing it. Seeing Ab major in the notation and feeling it under their fingers, they might have recognized it as a tonality that returns to the fourth impromptu from the first” (Fisk 2001, 123–125). Thus, the opening A section of the fourth impromptu not only recalls the Cb major and B/Cb minor emphasized in the second and third impromptus, but also evokes the B section of the first impromptu by using its prominent key, Ab major. In this sense, the fourth impromptu acts as the compilation of the all movements by recalling and summarizing the keys of the earlier impromptus, and also brings back the “remote memory” of Ab major to conclude this four movement-cycle.

Impromptu D. 899-No. 1 in C Minor

Let us look closely at each of the pieces in D. 899, using harmonic as well as linear analysis. The impromptu D. 899-No. 1, the longest piece of the set, starts in C minor. The harmonic framework of this piece is attached on page 77 (see graph 4.1-A). The graph lists the main key areas as well as some important harmonies bridging those keys (the measure numbers are provided above the chords). As you can see, these main key areas are related to each other by thirds (C to Ab, Ab to Cb, and G to Bb). Also, we notice that C minor not only appears as an opening key but also functions as a division of the formal sections of this piece—C minor appears three times in the piece, once in the opening, once from measure 91, and once from measure 164. These three appearances of C-minor divide the piece into five sections as follows; Cm→ Ab-Cb-Ab→ Cm→ Gm-Bb-Gm-G→ Cm-C.

Graph 4.1-B on page 77 shows a linear framework for the piece. This Schenkerian reduction of the melody shows the structural pitches in the melodic line and tells us how the linear connections between the different key areas are created. As you see, the structural pitches in the melody create a 5-4-3-2-1 (G-F-Eb-D-C) descending *Urlinie*. This graph not only proves that there are third relationships occurring between the key areas, but also shows descending lines connecting these key areas. A more reduced version of this Schenkerian graph is provided on page 77 (Graph 4.1-B'). This version shows that the entire melodic skeleton of the piece can be described in one long descending line, starting on high G and going down to middle C. We also see that there is an alternative ascending motivic line G-Ab-Bb-C. These two ascending and descending lines are working mutually as the background of the piece, giving rise to smooth key

transitions throughout the piece.

Graph 4.1-A: Impromptu D. 899-No. 1, Harmonic Transformation

mm.1 41 51 55 91 124 134 138 152 164 192

Cm Ab Cb Ab Cm Gm Bb Gm G Cm C

Graph 4.1-B: Impromptu D. 899-No. 1, Linear Framework

Cm Ab Cb Ab Cm Gm Bb G Cm C

i [V]→III V I

Graph 4.1-B': Impromptu No. 1, Linear Framework (more reduced version)

G-F-Eb-D-C descending *Urlinie*

G-Ab-Bb-C rising motive

The triadic shifts presented in graph 4.1-A are portrayed in a Neo-Riemannian (*Tonnetz*) graph on page 79. The arrows on the graph indicate the transformations. The triangles filled with color represent the main key areas, and the unfilled triangle on Ab minor represents a chord which links key areas. The opening C minor transforms to A-flat major, by means of the leading-tone exchange or L transformation. (The fifth of C-minor chord (G) moves up by a semitone (Ab).) Then, the transformation from Ab Major to Cb Major is via the Ab-minor chord, working as the bridge between two triads; Ab Major to Ab minor is a P (parallel) transformation, and it is followed by an R (relative) transformation, from Ab minor to Cb major. Then, after the re-appearance of Ab major, the music moves to C minor at measure 91, via the L transformation. Then, C minor transforms to G minor. G minor shifts once to Bb major at measure 134, but immediately goes back to G minor, then turns to its parallel key, G major. After G major modulates back to the home key (C minor) through its dominant relationship, C minor changes to C Major at the very end of the piece.

On the *Tonnetz* graph 4.1, the chords are placed around the center (where the opening pitch G is), almost equally and symmetrically on the right and left sides. These harmonic transformations around the center can be seen to represent the wanderer making a circular journey at a certain distance from his home. I will mention more details about the movement's association to the concept of "wandering" and its harmonic motion on the *Tonnetz* at the end of this chapter (pages 89–91).

Tonnetz Graph 4.1 : Impromptu D. 899-No. 1

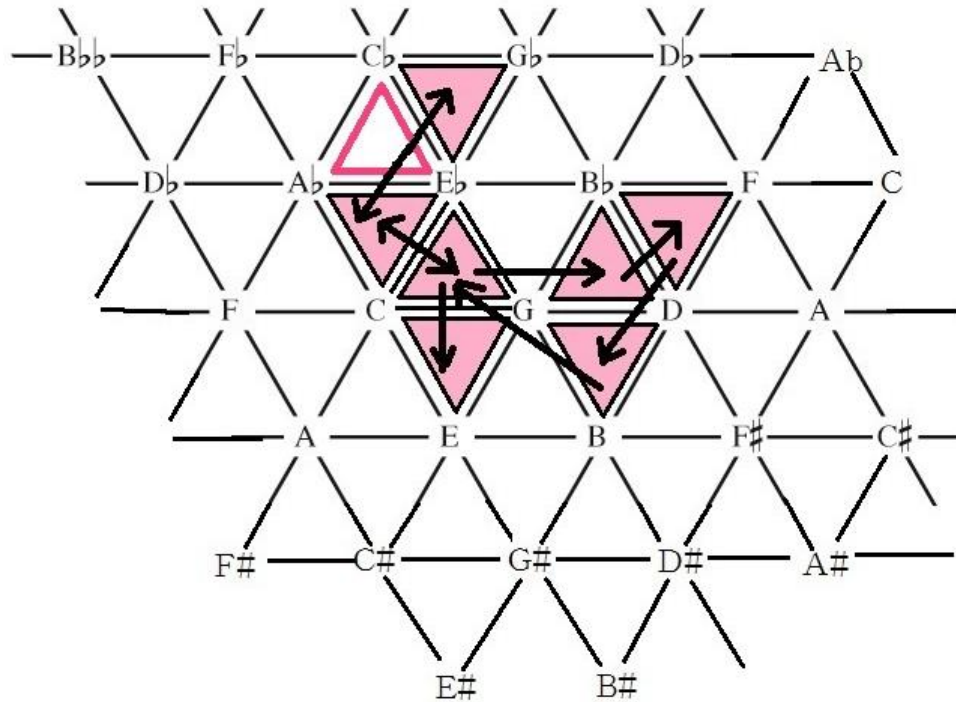

Impromptu D. 899-No. 2 in E-flat Major

The Impromptu D. 899-No. 2 is in Eb major. The harmonic and linear structures of the piece are provided on page 81 (Graphs 4.2-A and 4.2-B). In terms of its harmonic transitions, the most interesting moment in this piece is the modulation from Eb minor to B minor in measures 80–83 and 248–251. This happens at the formal transition from the A-section to B-section, transforming from a flat-key (Ebm) to a sharp-key (Bm). In order to produce this transformation, the composer utilizes an enharmonic exchange. He starts by transforming the Eb-minor chord to the Gb-major chord, and then, he treats this Gb-major chord enharmonically as an F#-major chord, the dominant chord in B minor,

smoothly resolving to its tonic. This enharmonic relationship between Gb-major and F#-major chords helps him to move from a flat-key to a sharp-key smoothly. (In the graph, these enharmonic chords are colored in blue.)

The transition from B minor to E minor through measures 127–135 can be understood better through linear analysis than by means of harmonic analysis. The score of the pertinent section, mm. 125–37, is provided below (Example 4.6). This section stays in B minor from measure 127 to 134, and it suddenly modulates to E minor in measure 135. While the V-I falling movement in the bass between measures 134 and 135 helps this modulation, this sudden transformation is more understandable when we consider the middleground of the soprano line through these measures, the ascending scale B-C#-D-E (mm127→130→132→135, assisting a smooth transition from Bm to Em.)

Example 4.6: Impromptu in E-flat major, D. 899-No. 2, mm. 125–137

The musical score for Example 4.6 consists of two systems of piano music. The first system covers measures 125 to 130. Measure 125 is marked *f* and contains a complex chordal texture with triplets and sixteenth notes. Measures 127-130 are in B minor, with a soprano line ascending from B to C# to D to E. The second system covers measures 131 to 137. Measures 131-134 remain in B minor, while measure 135 modulates to E minor. The bass line in measure 135 shows a V-I falling movement. The score includes various musical notations such as dynamics, articulation marks, and fingering.

Graph 4.2-A: Impromptu D. 899-No. 2, Harmonic Transformation

A
m. 1 25 52 71 B 83 102 127 135 146 159 A 169 193

Eb Ebm (Abm-Gb-Cb-Bb-Ebm) Eb Ebm (Gb=F#) Bm F#m Bm Em Bm Ebm (Bb) Eb Ebm

251 B'+coda 264

(Gb=F#) Bm (Bb) Ebm

Graph 4.2-B: Impromptu D. 899-No. 2, Linear Framework

A 5 B A B + Coda 5 4 3 2 1

Eb Ebm Eb Ebm Bm F#m Bm Eb Ebm Bm Ebm

All the harmonic transformations occurring in No. 2 are represented in the *Tonnetz* graph on page 82. On the graph, the main chords in the A-section are located horizontally around the Eb-minor chord. But when the piece gets to the B-section, after the enharmonic transition from Eb major to B minor, it leaves this horizontal chordal area and jumps into a different area consisting of chords with sharps. The graph visibly emphasizes the formal distinction between the A-section and B-section; the A-section consists of flat-chords or flat-keys while the B-section is composed of sharp-chords or sharp-keys. The transition between these two formal sections is delineated with the arrow

colored in blue. Also this distinction between sharp/flat chords is enhanced by the different musical and rhythmic characters of these two sections.

On the *Tonnetz*, the contrasting opening and ending keys (Eb major and minor) are placed vertically next to each other, showing their closeness, but their functions are contrasted, as they represent the wanderer’s conflicted emotions—his dream contrasted to the dismal reality. Also, the movement’s formation, like a *perpetuum mobile*, suggests its motion continuously returning to its own center rather than progressing forward. (Repeats of the opening phrase give us a sense of forever returning to its home; I will discuss more about this on pages 92–94.) These characteristics of this movement are paralleled on the *Tonnetz* graph in some ways. I will write about the details of this later in this chapter (pages 91–94).

Tonnetz Graph 4.2: Impromptu D. 899-No. 2

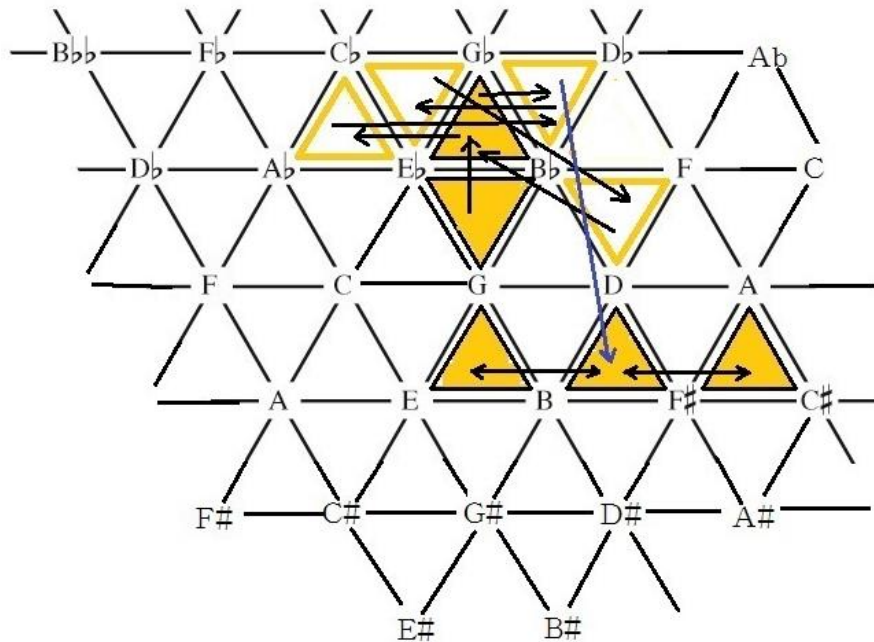

Impromptu D. 899-No. 3 in G-flat Major

The Impromptu D. 899-No. 3 is in Gb Major. This piece is the most pensive and intimate one in D. 899. The piece is in a simple A-B-A form, with sextuplet rhythms in the accompaniment that continue throughout the piece. The harmonic and linear structures of No. 3 can be found on page 84 (Graphs 4.3-A and 4.3-B).

As we see in these harmonic and linear reductions, the key areas in this piece connect to each other by third relations. Comparing it to the previous two pieces (No. 1 and No. 2), the key transformations in this piece are much more simple and smooth, and the third relations between the key areas operate according to a cyclic pattern (Gb-Eb-Cb-Eb-Gb). An interesting approach to harmonic shifting appears in the very last section after the arrival in Gb major in measure 78. The chordal reduction of this section is on page 85 (see graph 4.3-C). This reduction tells us that layers of enharmonic transformations link the different key areas (Gb-Bm-Gm-Gb). As we see in graph 4.3-C, three different layers of key area are connected through enharmonic equivalences. First, the section starts in Gb major in measure 78. This Gb major is treated as the dominant (F#-major chord) of B minor, then arrives at the B-minor chord (i-chord) in measure 79. Then, it proceeds to III7 (D7-chord), which is treated as V7 of G minor. After the D7-chord resolves to a G-minor chord in measure 80, it returns to V7 (D7) again, now treated as a German 6th chord resolving to its tonic Gb Major. In addition to these enharmonic layers, the other interesting transformational aspect in this section is the descending whole-tone steps played in the bass; the descending line Gb-Fb-D-C-Bb also creates smooth voice-leading in this section.

All the chord transformations found in this piece are portrayed on the *Tonnetz* on page 85 (*Tonnetz* graph 4.3). As you can see, most of these transformations are horizontal shifts in the graph, and the four main key areas, Gb, Ebm, Cb, and Eb, are all placed next to each other, forming a reversed triangle. This closely packed placement of the main key areas shows the single-tone displacements occurring between the chords. Also, the distinctive character of this piece is that the opening and closing keys are the same (Gb major), while the other three pieces in D. 899 start and end in different keys.

Graph 4.3-A: Impromptu D. 899-No. 3, Harmonic Transformation

Graph 4.3-B: Impromptu D. 899-No. 3, Linear Framework

Graph 4.3-C: Impromptu No. 3, Chord Transformation, mm. 78–81

Gb
 Gb: I
 Bm: V-----i-----III7
 Gm: V7-----i-----V7
 Gb: Ger6-----I

Tonnetz Graph 4.3: Impromptu D. 899-No. 3

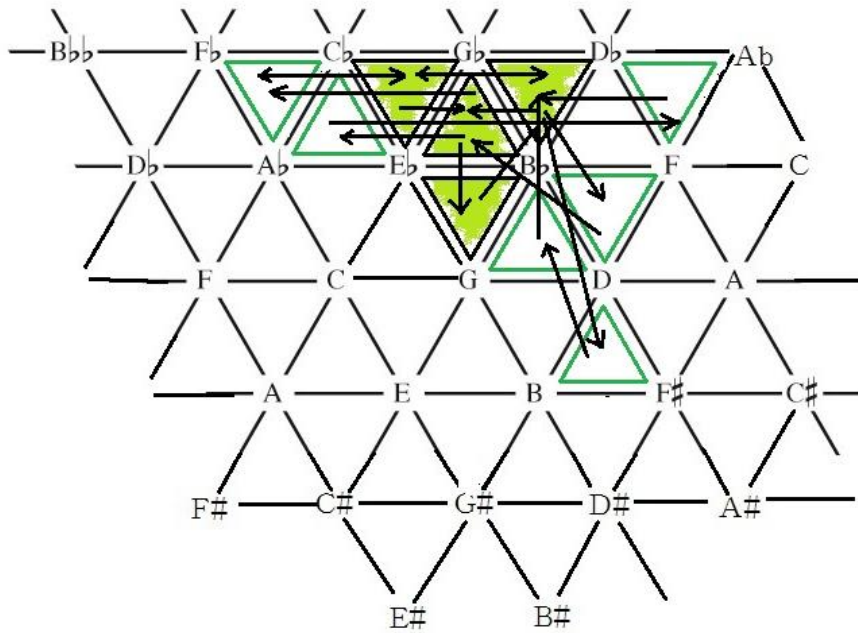

Impromptu D. 899-No. 4 in A-flat Major

The Impromptu No. 4, the last piece of the set D. 899, is in A-flat Major. Beginning

in its parallel minor key (Ab minor), the piece contains frequent modulations to different key areas throughout the piece. The harmonic and linear structures of this piece are provided on pages 87–88. The starting key, Ab minor, modulates to Cb major in measure 13, through single-tone displacement. The Cb major then goes to B minor in measure 19. This transformation also involves single-tone displacement, transferring from flat-key to sharp-key, via a Gb-major chord (working as the dominant linking both keys). After the arrival in B minor in measure 19, there is a long transformation from B minor to Ab major; the composer first modulates from B minor to G# minor, then moves to a C#-minor chord, that is enharmonically treated as Db-minor. Instead of going back to the opening key, Ab minor, the Db-minor chord then resolves to Ab major. Another interesting transition occurs between the A-section and B-section, mm. 103–107, where the Ab major (A-section) transforms to C# minor (B-section). Here, the enharmonic exchange, the Ab-major chord treated as G#-major, resolves as dominant to C#-minor and links the two sections. The linear reduction (graph 4.4-B) proves that these key transitions are not only created by the harmonic movements but also motivated by the ascending/descending lines. It shows that the key transformation $DbM \rightarrow AbM \rightarrow C\#m$ in mm. 62–107 is supported by ascending steps, Db-Eb-F-G-Ab(G#). Also, while the difference between flat (A-section) and sharp (B-section) keys creates a clear contrast between the A and B sections, the distinction between these sections is also revealed by two divided structural lines, C (or Cb)-Bb-Ab (A-section) followed by the line G#-F#-E-D#-C# (B-section).

The *Tonnetz* graph 4.4 on page 88 shows all the harmonic transformations involved in No. 4. On the graph, the brown arrow represents the principal key shift which forms a

circular formation, while overall chord-transformations in this piece look more complicated than in other movements. The transformations between the distant chords on the graph are achieved mainly by Schubert's use of enharmonic progressions.

In my harmonic analyses of these four pieces of D. 899, I have used *Tonnetz* graphs to describe the chord transformations occurring in each piece. The graph on page 89 (*Tonnetz* Graph 4.5) compiles all of these four *Tonnetz* graphs we have seen into one graph, showing prior chords and key-areas through the entire work. The different colors signify the different movements of the set D. 899. (No. 1: colored in pink, No. 2: colored in yellow, No. 3: colored in green, and No. 4: colored in blue.) As we see here, the chords on the graph create the shape of a reversed triangle, even though some chords are placed outside the triangle. This triangle configuration can be understood as the network unifying the four pieces of the set. This triangle-shaped network demonstrates that the chord-transformations throughout the four pieces can be heard as unified, in that they create a single configuration for the set as a whole.

Graph 4.4-A: Impromptu D. 899-No. 4, Harmonic Transformation

m.1 13 19 31 58 62 72 107

Abm Cb (Ebm-Gb=F#) Bm (F#7-G#m-C#m=Dbm-Abm-Eb) Ab Bbm Db Ab(=G#) C#m
 (Eb-Abm-Ebm) (Eb-Ab-F) (Ab)

139 157 173 203

C# C#m Abm Ab

Graph 4.4-B: Impromptu D. 899-No. 4, Linear Framework

mm.1 31 64 107 173 203
 b3 3 2 1

Abm Ab (Bbm)(Db) Ab C#m C# Abm Ab
 ii^o6 i V^{6/4}-5/3 I

Tonnetz Graph 4.4: Impromptu D. 899-No. 4

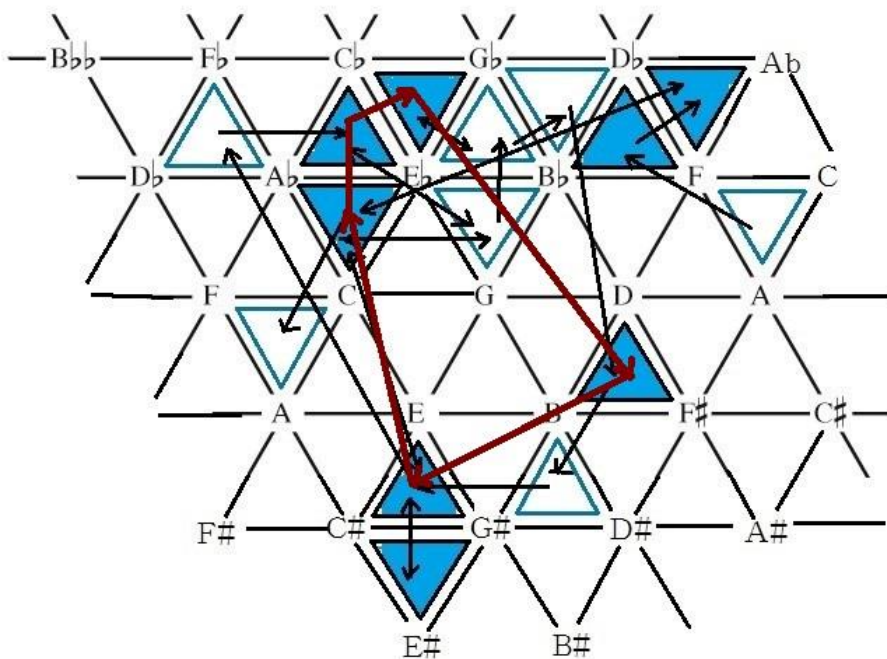

Tonnetz Graph 4.5: Impromptus D. 899 (Nos. 1–4)

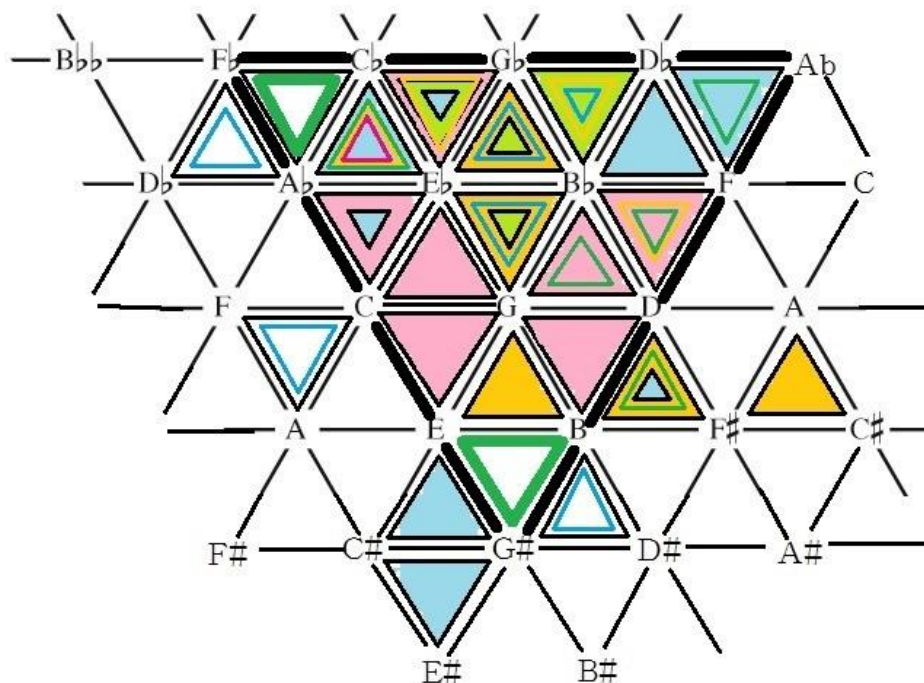

In the remaining section of this chapter, I would like to discuss how this triangle configuration represents the wanderer's journey and the conception of wandering. One obvious parallel is that the chords/keys used in the first impromptu are located near the center of the triangle-shape on the graph, while the final impromptu mainly involves the chords/keys placed near the edge of (or sometimes outside of) the triangle. This formation, chords shifting from the central area to the edge of the configuration, could represent the "wanderer" leaving his home (center) and meandering into the distant lands (edges).

As I mentioned at the beginning of this chapter as well as in chapter 1, these Impromptus' close associations with the image of the wanderer's journey have been remarked upon by previous authors. Charles Fisk demonstrates such associations, mainly

through the correspondence of the Impromptu to the *Winterreise* songs. Fisk presents correspondences between the first Impromptu and the opening song “Gute Nacht” from *Winterreise*; he says that “its walking tempo, its constant momentum, its repeated chords and melodic tones, its two dotted figures (one shorter, one longer), and its ambiguous turns to major at the end,” all recall “Gute Nacht” (Fisk 2001, 28). As I mentioned in chapter 1, William Kinderman also writes about the processional rhythm of the introductory phrase of the first Impromptu, “evoking the landscape of ceaseless wandering” depicted in *Winterreise*. Also, John Bell Young claims that the opening G octaves and the sustained dominant pedal represent the wanderer’s sentiments of longing for home and stagnant emotion. Fisk states that the songs in part I of *Winterreise* create the sense of the Fremdling’s walking motion, especially the song “Der Wegweiser,” and the same image corresponds to the atmosphere of the first Impromptu. Fisk writes that “the central image of “Der Wegweiser,” the signpost pointing to the protagonist’s death, whether actual or psychological, is already foreshadowed in the poems of the first part. It is suggested by the wanderer’s self-description as a “Fremdling,” a stranger; by his compulsion to see himself mirrored in elements of the frozen landscape, first in his moon shadow and footsteps, then in the wind-buffeted weathervane, then more pervasively in the barrenness of the ice and snow, and ultimately in a tired cloud; and by his related compulsion to attribute to the rest of humanity a collective consciousness so diminished by hostility that it can communicate to him only through the barking of dogs and the shrieking of ravens. Each of these images is a token of his existential state, a foreboding, like the signpost itself, of his psychological annihilation through obsession and inescapable isolation” (Fisk 2001, 28–29). Fisk claims that these same images are deeply

reflected in the instrumental pieces written after the *Winterreise* songs. He writes that “because such tokens, such virtual signposts, already pervade the first part of *Winterreise*, an instrumental piece written in response to these songs might, in the absence of words, come into focus through the musical embodiment of such a signpost” (Fisk 2001, 29).

The first impromptu starts in a tempo and rhythm that recalls the wanderer’s trudging in darkness, fully reflecting the wanderer’s loneliness and hopeless emotion. It seems to me that the *Tonnetz* graph represents such sentiments of the wanderer, who begins his wandering journey in the feeling of isolation from his home. On the *Tonnetz* graph, the first Impromptu consists of chords and keys near the center of the triangle, almost equally on both sides around the center, as if it represents the beginning of the wanderer’s journey where he still strolls around his home, but he already recognizes himself as the “fremdling,” the stranger, who is separated from home. Moreover, on the graph, the pitch G is at the center of the triangle—considering Schubert’s choice of octave Gs as the Impromptus’ opening pitches and the significance of that pitch in the first Impromptu, it seems to me that the center of the triangle represents the wanderer’s home, or his longing for home, and this is the place where his wandering starts and where his mind stays centered throughout his journey.

At the beginning of this chapter, I mentioned the contrast between the major and minor modes of the second impromptu and its close bond to the third impromptu. The opening Eb major of the second impromptu associates with the wanderer’s dream, hope or illusions, but the ending of the piece is in the parallel minor, contrasting to the opening major mode. The threat of the minor mode is resolved, or at least relieved, by the appearance of the Gb major of the third Impromptu. This Eb-Ebm-Gb harmonic process

is easily perceived on the *Tonnetz* graph; the Eb-major triangle at the center moves up to the Eb-minor triangle by semitonal displacement (a P transformation), and it proceeds to the Gb-major next to it by the R transformation. Also, the Cb-major harmony that forms the bridge between the two impromptus is placed next to the Eb-minor triangle—these four harmonies, Eb, Ebm, Cb, Gb, create a small reversed triangle on the graph, showing us their unity and illustrating the association between the two Impromptus. Also, it is easily perceived from the graph that the second and third Impromptus share these four keys (or chords), showing their close bond to each other. The graph makes it easy to understand the closeness between the chords of this harmonic procedure, related to each other by single-tone exchanges, and this closeness represents the wanderer's conflicting emotion between his despair and hope by showing us how easily major keys can transform to minor and *vice versa*.

Fisk points out the particular formation of the opening phrase of the second Impromptu. (The score of the opening section is attached on page 93, Example 4.7.) He writes that “the minor ending of the Eb-major impromptu is extraordinary, perhaps even unique, for the time of its composition. The beginning of this Impromptu is also extraordinary. To repeat an opening phrase is common; to repeat it twice is not. The music begins to take on the character of a *perpetuum mobile*, suggesting a motion that forever returns to its own center rather than generating any further progression. And indeed, instead of advancing to some new goal after its third phrase, this music continues at first to adhere to its own center, withdrawing quietly into its parallel minor in a first premonition, however ingratiating, of the music's calamitous outcome” (Fisk 2001, 46).

Example 4.7: Impromptu in E-flat major, D. 899-No. 2, mm. 1–28

15

Allegro

2. *p* *legato*

5

10

15

20

25 *pp*

This formation of the second impromptu, the formation of continually returning to the center, is paralleled on the Tonnetz graph. On the graph, its main key, E \flat major, is placed

on the very center of the triangle. Furthermore, it is obvious that this Eb major is placed right above the pitch G—the opening pitch of the whole work, the home of the wanderer—as it involves this pitch as one of the three chord tones. The placement of the chord on the center of the triangle accords with the opening phrase’s tendency to return to the center again and again, representing the wanderer’s longing for home in his heart all the time.

Fisk argues that the fourth Impromptu relates to Schubert’s song “Der Wanderer” in many ways. He writes how its trio section corresponds to the song (the score is provided on page 95 and 96, Examples 4.8 & 4.9);

The opening of its trio is a variant of the song’s central melody. It shares with that melody its C#-minor tonality, an opening melodic gesture confined to the fifth scale degree and its upper neighbor, its repeated melodic emphasis of this scale degree, and its almost immobile opening harmonic progression, i-V6/5-i. Also as in “Der Wanderer” and especially in the fantasy, an augmented sixth harmony has great prominence in this trio, as the most registrally and dynamically marked harmony of its dramatic middle section (mm. 127–128, repeated in 135–136). As in the setting of “wo, immer wo?” in the song, the melody of this climax, resonating with the trio’s opening neighbor motion, lingers on a D# that is intensified by an upper neighbor. After the climax, the “Wanderer” melody appears in the major (m.139), thus recalling the two maggiore variations in the fantasy. In spite of its different form, then, this entire trio holds enough resonance with the “Wanderer” theme to feel like a new, composite variation on it.” (Fisk 2001, 72–73)

Fisk also interprets the opening section of the fourth Impromptu as representing wandering. (The score of the opening section is attached on pages 99–100, Examples 4.10 & 4.11.) He says that the opening six-measure phrase units are unbalanced—

while the sentence structure that classical sonatas normally open with consists of a two-measure basic idea that is repeated and followed by a four-measure continuation, this impromptu's beginning has a descending arpeggiated figure of two measures repeated (mm. 1–4), and these 2+2 measures are followed by only two-measures of continuation. The consequent phrase starting in measure 7 is the return of the opening phrase, suggesting “a new attempt to begin, a search for a truer beginning, without quite knowing how” (Fisk 2001, 74). The impression of searching is intensified by the appearance of Cb major in measure 11 and its immediate modulation to Cb (B) minor in measure 19. Through these attempts to begin the same phrase in different keys, the piece finally reaches Ab major in measure 31. Fisk

Example 4.8: Impromptu in A-flat major, D. 899-No. 4, mm. 107–116

Example 4.9: Impromptu in A-flat major, D. 899-No. 4, mm. 121–129

writes that “the repetition of the opening arpeggiation becomes fourfold and finally yields to the kind of motivic liquidation that might have occurred in an opening sentential phrase (m. 39). The resulting shorter, one-measure arpeggiated figures, their progression repeated to confirm the expansion of the opening six-measure unites into more balanced eight-measure ones, now become the accompaniment for the impromptu’s first true melody, brought by the left hand (m. 47)” (Fisk 2001, 74). Thus, the search for its own true beginning in the opening section of this Impromptu reminds us of the wanderer searching for his home.

The fourth Impromptu’s associations with the song “Der Wanderer” and its opening’s “searching” impression fully express the image of the wanderer who longs for his home while strolling through different lands. Fisk claims that “because this Impromptu begins not with an assertion of a stable theme or tonality, but with a quest for them, their arrival (in Ab major) brings to the music a sense not only of joyous release but also of lingering uncertainty” (Fisk 2001, 77). Especially, the trio’s C# minor creates the

sense of uncertainty. Fisk writes that “because Ab major is not given from the start but is instead only achieved, and because C# minor can be heard as a negation of Db major, the constituent of Ab major on which the music has especially depended for its assertion, the music of the trio suggests a denial of that achievement. On one description, the music—or its main protagonist—begins outside of Ab major; it eventually gains admittance to that region, but in the trio it finds itself outside again, a Fremdling, as at the beginning” (Fisk 2001, 77). In this sense, the temporary arrival in Ab major and its shift to C# minor suggest the uncertainty of a wandering journey; the arrival in Ab major seems to represent the wanderer’s arrival at a place to stay or at his home, but it is just a dream or illusion—the appearance of C# minor breaks his dream and brings him back to reality, where he has nowhere to rely on and where he wanders in alienation.

The sense of searching for home and the protagonist’s alienation that we perceive in the fourth Impromptu is represented clearly on the *Tonnetz* Graph (on page 88). On the graph, the frequent modulations to different key areas are shown by the arrows connecting the remote triangles. From this, we can visibly discern the sense of a wanderer’s searching for home, trudging through different places. Also, the contrasting images of Ab major and C# minor are reflected on the *Tonnetz* graph 4.5 on page 89. While Ab major, the key of “arrival” in his illusion, is placed inside the triangle configuration on the graph, C# minor is outside the triangle, showing the alienation of the wanderer who feels loneliness. Moreover, as I mentioned before, the main key areas involved in this piece are mapped near (and outside) the edges of the triangle, showing the wanderer’s feeling of alienation and despair growing more intense in his mind through his wandering journey.

Thus, I suggest that the triangle configuration on the *Tonnetz* graph corresponds to the wanderer's journey and his inner sentiments. As the graph shows, the harmonic procedures and key modulations in these four Impromptus represent the wanderer's life, struggling between his hopeful dream or illusion and his reality of loneliness and dismay, while searching and longing for home. In addition, the essential quality of "wandering"—"the construction of the landscape where every point is equally close to the center and equally close to death"—which I discussed in chapter 2 and 3, coincides with the triangle-configuration on the *Tonnetz* graph. (The triangle holds its center, and also the edges keep a certain distance from the center.) So, I believe that the configurations on the *Tonnetz* graph represent the conception of "wandering" itself. Through representing the image of the wanderer, sometimes by means of its correspondence to *Winterreise* songs, this set of four Impromptus expresses the concept of wandering and the cyclic formation of human life.

Example 4.10: Impromptu in A-flat major, D. 899-No. 4, mm. 1–30

┌ Sentence Structure (2+2, followed by 2-measure continuation)

1

4

9

14

19

23

pp

f *decreso.* *p*

Example 4.11: Impromptu in A-flat major, D. 899-No. 4, mm. 31–42

31 *pp*

35 *cresc.*

39 *pp*

CHAPTER V

MOMENTS MUSICAL, D. 780 (1823-28)

Moments Musical D. 780 is a collection of six short pieces, composed by Schubert between 1823 and 1828. The six pieces are forerunners of the “characteristic piece,” a genre which was cultivated during the nineteenth century. William Kinderman writes that “Schubert’s *Impromptus* and *Moments Musicaux* develop a tradition of characteristic piano pieces stemming from the Bohemian composer Václav Tomášek, and transmitted to Vienna by his pupil Jan Voříšek, who took up residence there in 1818” (Kinderman 1997, 166). Although the six pieces were written in different time periods and are in different characters, they are unified through a number of relations connecting them. A diagram of relationships between the six pieces is attached on page 104 (Diagram 3). This diagram shows the opening and closing keys of each movement and relations between them in terms of their keys, meters, and intervals. Like in the *Impromptus* D. 899, third relations between the tonic keys occur again in this set. This cycle of third relations, or the circle of thirds, is made up of the alternation of major/minor thirds. The interval relationships between the tonic keys are described on Diagram 2 below.

Diagram 2: Intervallic relationships between the tonic keys (*Moments Musical*)

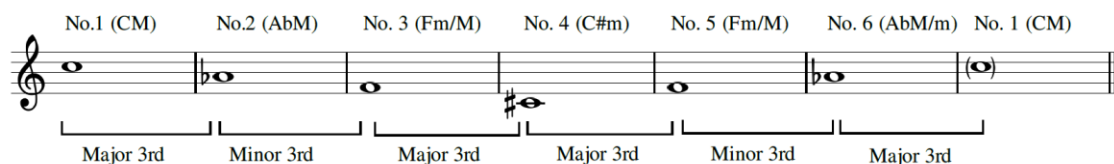

Also, in addition to the third relations, there are other kinds of links happening between the pieces. Firstly, we can divide these six pieces into two groups, Nos. 1, 2, and 6, and Nos. 3, 4, and 5, according to their meter types (triple or duple) and key types (major or minor). Nos. 1, 2 and 6 are all in triple meter and in major keys, while Nos. 3, 4, and 5 are all in duple meter and in minor keys. There is another way to group these six pieces; we can divide the set into three groups, where each group contains two pieces related to each other in some way: No. 1 and No. 4 both have opening themes in broken-chord style (the opening measures of No. 1 and No. 4 are provided below to compare, Example 5.1); No. 2 and No. 6 are related since they are in the same key (A \flat major) and both contain modulation by means of descending chromatic scales (the scores of the sections in which the modulation occurs are attached on the next page, Example 5.2); No. 3 and No. 5 are in the same key (F minor), and both modulate to F major at the end.

Example 5.1: Opening measures of Moment Musical No. 1(top) and No. 4 (bottom)

Moderato

Moderato

Example 5.2: Chromatic modulations in No. 2 (top; EbM→DbM) and No. 6 (bottom; AbM→EM)

14

Cb-Bb-----Bbb-----Ab
Ab-G-----Gb-----F

pp *f* *p*

Cb-----Bb---Bbb---Ab

58

C-----Cb-Bb-----B

f *ff*

Kinderman provides additional perspectives to divide the set into groups. He writes about the formal resemblance between No. 2 and No. 4: both include internal contrasting sections. Kinderman explains those sections as follows; “the main theme of the second piece in A-flat major is somewhat reminiscent of the beginning of the G-major sonata in its rhythm, broad choral texture, and serene character, while the two episodes present a haunting melody in F-sharp minor, accompanied by triplets in the left hand. In the fourth piece, the expressive contrast of the principal sections is striking: a *moto perpetuo* in C-sharp minor in a stratified Baroque texture is interrupted by a soft, ethereal theme in the major reminiscent of a dance, which recurs fleetingly before the conclusion” (Kinderman

1997, 167). Kinderman also claims the relation between No. 3 and No. 5, both in the same key (as I mentioned before) and linked by their unbroken rhythmic movement. Schubert makes use of broken and unbroken figures to contrast and unify the pieces in *Moments Musical*. As I mentioned, the broken-chord opening melodies of No. 1 and No. 4 relate the two pieces. No. 3 and No. 5 are related to each other by rhythmic movements in unbroken figures. In a similar way, the remaining pieces, No. 2 and No. 6, are related, both starting with a lyrical theme built on block chords.

Diagram 3: Relation between the Movements (Moments Musical D. 780)

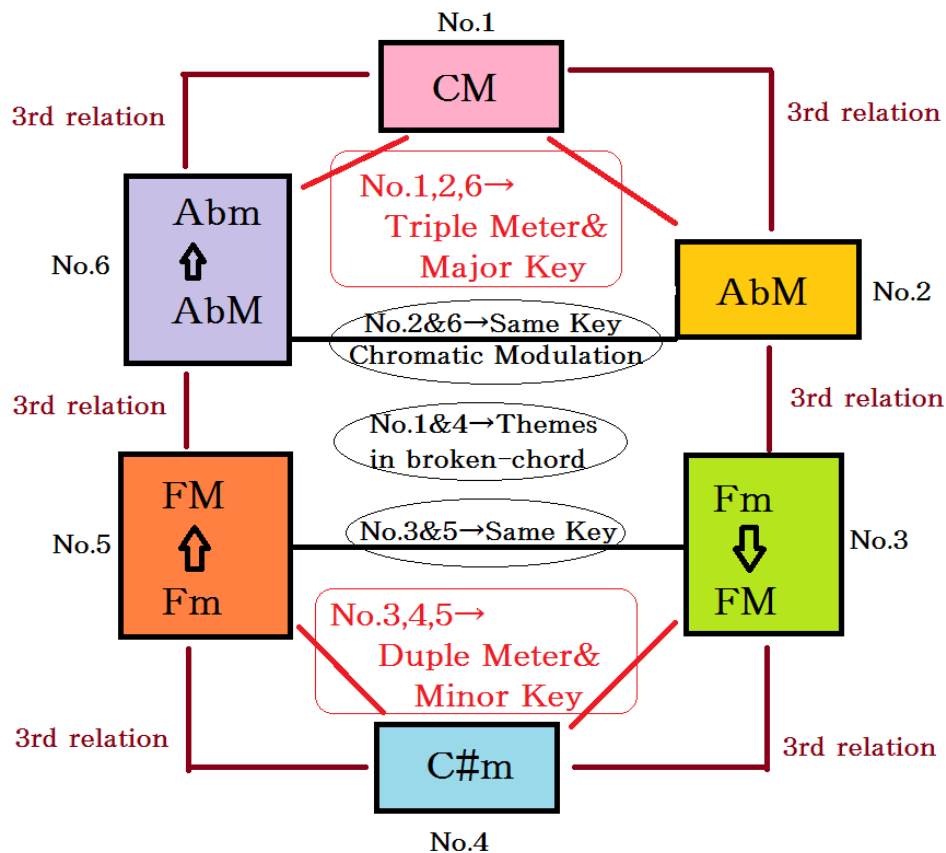

Moment Musical D. 780-No. 1 in C Major

The first piece of *Moments Musical* is in C major and in ternary form. While the contrast of the A and B sections is conspicuous in Moments Musical No. 2 and No. 4, Kinderman writes that this piece's ternary form has "a less pronounced contrast between the principal sections" (Kinderman 1997, 167). Because the modulations only occur between related keys, and the middle section starts in a major key, no conspicuous contrast seems to be created between the sections. Also, the broken chord in triplets is used throughout the piece; the continuous rhythm and texture unify the piece, while they weaken the contrast between the A and B sections.

An overview of the harmonic progression through the piece is provided below (graph 5.1). As in chapter 4, this graph shows harmonic transformations with the main key areas and some important chords to link those keys. (The filled-in notes are the chords/keys temporally arriving between the main key areas.) The measure numbers and formal sections are provided above the chords.

Graph 5.1: Moment Musical No. 1, Harmonic Transformation

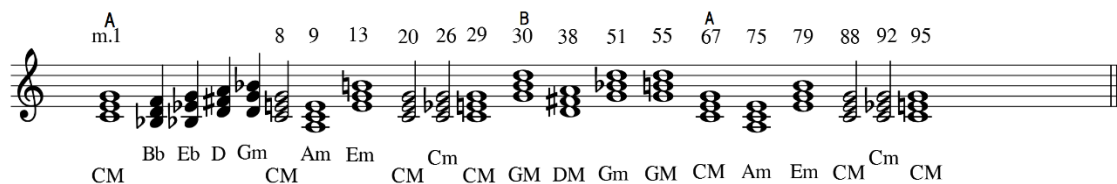

The piece starts in C major, with a broken chord fanfare-like theme in unison. The appearance of the C-minor chord in measure 5 leads to the sequential progression BbM→

EbM→DM→Gm through measures 5 and 6. This sequential progression implies modulation, but contrary to that expectation, the opening period concludes in C major in measure 8 with a V-I cadence. The piece suddenly shifts to A minor in measure 9. After the temporary arrival on G major in measure 12, it modulates to E minor in the next measure. In measure 20, the opening broken-chord theme re-appears in the bass line, followed by the same theme played alternately by the soprano and bass lines. Like the opening, the temporary modulation to C minor in measure 26 is followed by a four-chord sequential progression, and it proceeds to the section's final arrival on C major in measure 29.

The middle section starts in G major with broken chord triplets, and modulates to D major in measure 38. From measure 45, it pretends to modulate back to G major, but a long sustained dominant (D-major) harmony resolves to G minor on the downbeat of measure 51. After the middle section's main theme comes back in the parallel minor, it modulates back to G major in measure 55. After this middle section, the whole A section returns in the same keys as the opening.

The overall harmonic progression is described on a *Tonnetz* graph on the next page (*Tonnetz* Graph 5.1). On the graph, the chords are all placed next to each other, almost all sharing two common tones. The exception is the D-major chord, which is remote from the tonic key. As the D-major triad is geometrically separated from the other chords on the graph, the D-major section, which comes in the very middle of the piece, contrasts musically with the preceding sections. (Although, D has the same relationship with G as G had with C.) The opening A-section starts in C major, both hands playing the same melody in octaves (the score of the opening measures is attached on page 108, Example

Tonnetz Graph 5.1: Moment Musical No. 1 (D. 780-1)

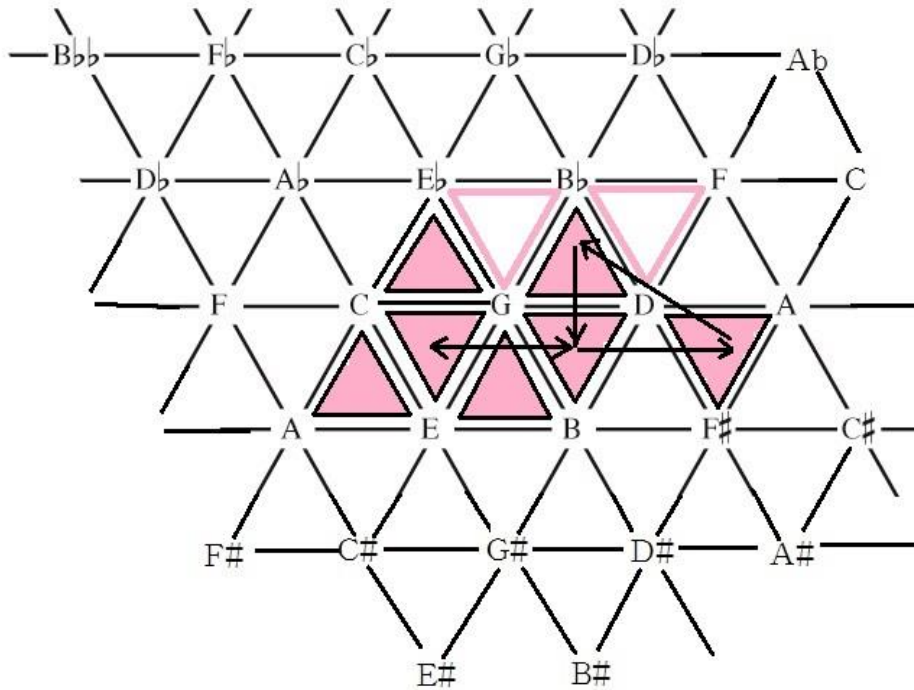

5.3). In the middle section in G major from measure 30, the broken chord triplets are played by both hands in a contrary motion, mirroring to each other (the score is on page 108, Example 5.4). But in the following section in D major, the triplet figure only remains in the left hand, while the right hand plays the chordal melody (the score is on page 109, Example 5.5). By changing the musical and rhythmical texture slightly, the affinity of the synchronized texture and rhythm between the right/left hands is weakened in this section. This, the process of losing the mirrored musical textures between the hands, is almost like the protagonist's dream or illusion becoming distant or receding in his mind. Also, the left-hand pianissimo triplets in a lower register enhance this sense, seeming to portray a distant dream. The D-major section is the most remote from the

opening section not only in terms of the key, but also in terms of the musical and rhythmical texture; this almost describes the wanderer's illusion gradually disappearing—in the opening, the protagonist's dream is filled with his happy memories of times past, but these gradually recede as the piece continues. The wanderer's dream becoming distant is also portrayed on the *Tonnetz* graph; with the C-major chord as a center, the D-major chord is in a distant place, separated from the other chords. Even though the contrasts are subtle ones (according to Kinderman), the differences and changes of the musical texture between the sections describe the mental dissociation of the wanderer, depicting his dream fading away.

Example 5.3: Moment Musical No. 1 (mm. 1–2; C major)



Example 5.4: Moment Musical No. 1 (mm. 30–31; G major)



Example 5.5: Moment Musical No. 1 (mm. 38–39; D major)



Moment Musical D. 780-No. 2 in A-flat Major

The second piece is in Ab major; the harmonic transformations in this piece are represented below (Graph 5.2). As Kinderman writes, the shift from major to minor modes between the internal sections create the main contrast. The opening section, which has a floating or dreaming quality, suddenly changes to the mood of lament or sorrow by transforming from major to minor mode at measure 18. The contrast between the A and B sections is created not only by the major/minor keys, but also by the texture and rhythm. Contrasted to the opening's unbroken chords played by both hands, the B section features a single-line melody in the right hand, accompanied by the left hand's broken chord triplets.

Graph 5.2: Moment Musical No. 2, Harmonic Transformation

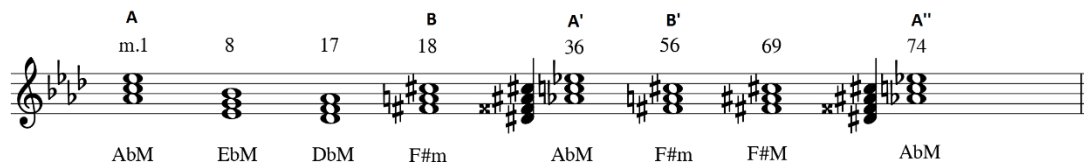

As I mentioned in Chapter 3 (see pages 43–45), Charles Fisk writes about the image of wandering associated with this piece. Even though the piece does not use any quotations from the Fremdling songs, Fisk describes the characteristic expression of “wandering” in this piece. Fisk says that the B section in F# minor brings clarification, answering the musical ambiguity of the opening A section. He writes as follows;

Despite its quintessentially Schubertian delicacy and stillness-in-motion, the opening theme of this piece teems with ambiguities. Without the help of the score, can anyone who hears it tell whether it begins with an upbeat or a downbeat, or whether its meter is triple, as it initially seems, or duple, as it seems a few bars later? Is it song or dance? Is it headed anywhere? Will it remain in the major, or will it succumb—like the other Moment Musical in Ab-major (No. 6) or the Eb-major impromptu—to its minor inflections? Will it ultimately prove serene or troubled? Because of these ambiguities, the calm of the opening is suffused with doubt, as if the theme were asking if that calm—or the tenderness within it—could ever become real. Only the arrival of a second, or B, theme brings clarification. This theme leaves behind every ambiguity of the opening theme: it is clearly a solo song with a distinct accompaniment; clearly in a new key, toward which the opening theme headed at the last moment; clearly a parallel period, despite the different lengths of its two phrases; and also clearly derivative of the opening theme, with its opening semitonal upper neighbor figure. (Fisk 2001, 278)

As Fisk writes here, the B section clarifies the opening ambiguities. (The scores of the opening measures of the piece and the beginning of the B-section are attached on page 111, Examples 5.6 & 5.7.) This is the moment when the wanderer’s foggy or unclear illusion is fading away and reality comes back. This B section is in a minor key, representing the wanderer’s dismay and loneliness. Fisk claims that its key, F# minor, is remote from the opening key, providing us a sense of the wanderer’s exile or loss.

Example 5.6: Moment Musical No. 2 (mm. 1–4)



Example 5.7: Moment Musical No. 2 (mm. 18–21; B-section)



As the contrast between the A and B sections in the opening represents the wanderer’s illusion fading away and changing to reality, the return of the A and B sections also contrast with each other and to the opening A and B sections. Instead of having a new contrasting C section after the opening A and B sections, like many of Beethoven’s and Mozart’s pieces do, Schubert chose to have returning A and B sections in transformed versions. In these returning sections, as Theodor Adorno writes (Adorno 2005, 10), Schubert’s theme shifts “in perspective” and “through a change of light”: the opening themes come back but are looked at through other angles. In Moment Musical No. 2, the A’ section from measure 36 is a return of the opening music with a more floating, dream-like quality. This returning A section gives an impression of a reappearing dream or illusion in the wanderer’s mind, but because of its transformed melody and harmony, this time the illusion seems to be something more distant and out of his reach.

The following returning B section also contrasts with the original B section in some ways. Fisk says that “the return of the B music is violent and disjunctive in ways that dramatize the tonal distance of its F# minor from the Ab major of the A sections” (Fisk 2001, 280). This returning B section starts in an intense and furious forte, contrasted to the original B section which was in a plaintive pianissimo. The music modulates to its parallel major key, F# major, at the end of the section. Fisk writes that “after one anguished phrase, this B music reverts to its original quiet disposition. But then, for its final measures, it turns suddenly to the major, in what feels like an epiphany, a transformative ‘moment musical.’ The change to major both stills the pain of the B theme itself and brings it tonally closer (as Gb major) to Ab major. It illuminates a homeward path from B to A” (Fisk 2001, 280). The sudden and unexpected change from tragic music in the minor mode to the peaceful major mode in this section is just like the wanderer’s transforming his emotion from the dismay of his reality to the serene feelings of his dream. (The score of the returning B-section is on the next page, Example 5.8.)

Fisk also writes about the correspondence between the formal structure AB’A’B”A” of this piece and the story of Schubert’s allegorical tale “Mein Traum.” As Fisk states, the ABABA form is a Schubertian specialty, used in several of Schubert’s pieces. In the tale “Mein Traum,” the protagonist’s sequential life events, his returning home and exile, are portrayed. The alternating A and B sections of the Moment Musical No. 2 are analogous to the story, where each A section represents his homecoming and each B section represents his exile. Fisk writes that the F#-minor B sections are the “potential musical realizations of its scenes of exile” (Fisk 2001, 280). He says that the anger of the protagonist’s father portrayed at the scene of his second exile is reflected in

the piece, in the returning B section starting with its violent forte. Also, the modulation to F#-major at the end of that section corresponds to the scene of circling around the dead maiden's tomb.

Example 5.8: Moment Musical No. 2 (mm. 56–73; returning B-section)

The *Tonnetz* graph of the harmonic transformations in this piece is on the next page (*Tonnetz* Graph 5.2). As we see, the graph shows the progression Ab→Eb→Db major in the opening A section, where these chords are placed near to each other in a line. The F# minor (and its parallel major) of the B section is placed at a distance from these three

major chords on the graph, depicting the contrasting A and B sections. The protagonist's struggle between dream and reality, or between homecoming and exile, is geometrically represented on the graph. The apparent separation between the A and B sections on the graph demonstrates and reinforces the piece's association with Schubert's tale "Mein Traum."

Tonnetz Graph 5.2: Moment Musical No. 2 (D. 780-2)

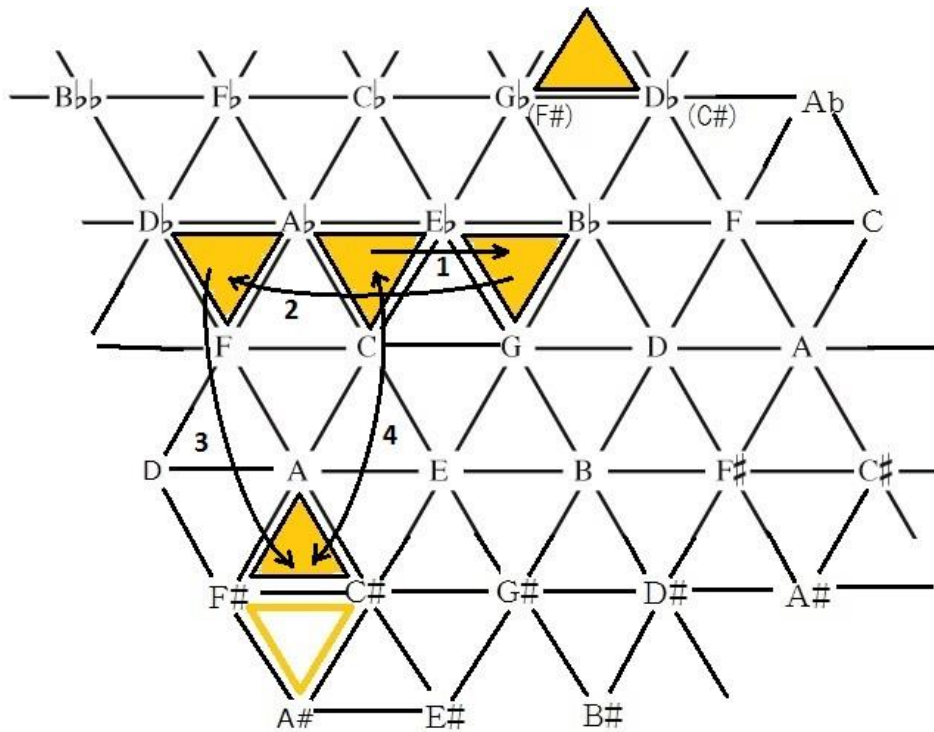

Moment Musical D. 780-No. 3 in F Minor

The third piece is a short piece in F minor. This is probably the most popular piece in the set and was well known even while Schubert was alive. In the piece, the staccato eighth-notes in the left hand continue throughout monotonously while the right hand plays the characteristic melody which reminds us of Russian dance music.

The harmonic modulations in this piece are very simple (see Graph 5.3 below). Having F minor as its tonic key, the piece only modulates to its relative and parallel majors. Unlike the second piece, this piece does not contain any modulation to distant keys. The opening F minor modulates to Ab major at measure 11. After an 8-measure period in Ab major, it temporarily transforms to F minor through measures 19–22, but shortly after it modulates back to Ab major. The returning A section from measure 27 is followed by a coda, which modulates to F major at the end. These uncomplicated harmonic modulations are described on the *Tonnetz* (on the next page). Centering on F minor, these keys are placed next to each other, connected by single-tone displacements. There is no certain evidence to prove the piece's association to the image of the wanderer. However, the key transformation in this piece, the alternate major and minor modes, does seem to correlate with the wanderer's alternating hope and despair, or with the protagonist in "Mein Traum" who repeats his homecoming and exile alternately.

Graph 5.3: Moment Musical No. 3, Harmonic Transformation

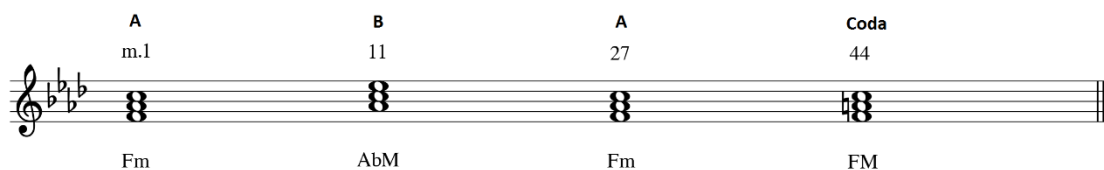

Tonnetz Graph 5.3: Moment Musical No. 3 (D. 780-3)

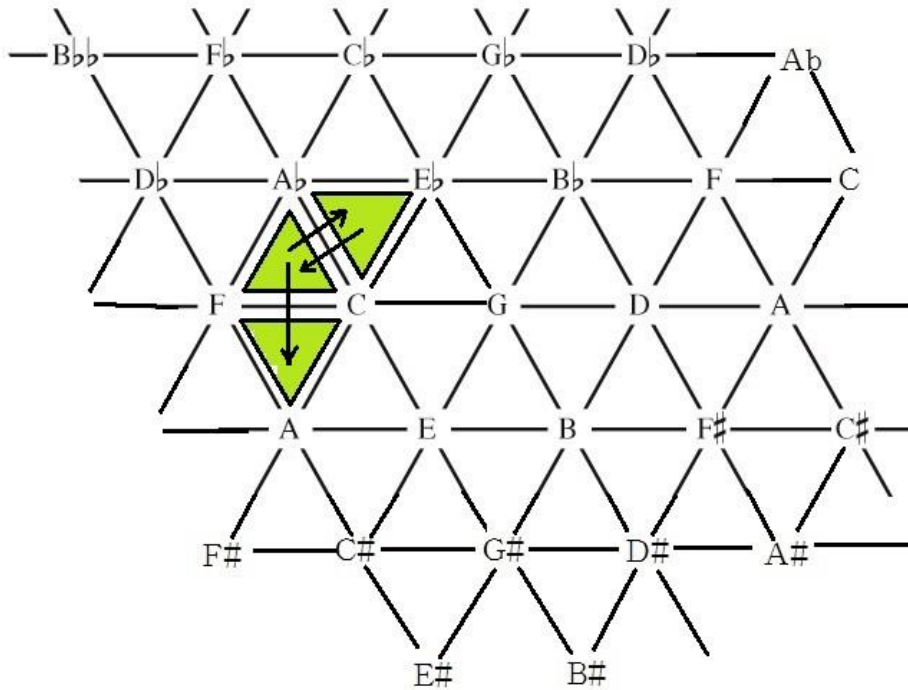

Moment Musical D. 780-No. 4 in C-sharp Minor

The Moment Musical No. 4 is in C \sharp minor and in ternary form. The A sections feature a right-hand sixteenth-note melody in *moto perpetuo* style, accompanied by the left hand's simple eighth-notes. The B section presents a calm D \flat major in dance-like rhythm (in which the first upbeats are accented in each measure), contrasting to the A section's minor mode. The texture of the B section also contrasts with the A sections; the two-note chords are played in the right-hand melody while the left hand plays the octave chords. As Kinderman writes, the contrast between the principal sections is apparent in their mode and texture. Just as in Moment Musical No. 2, the contrast from minor to major modes between the sections in No. 4 seems to reflect the wanderer's dismal reality

Graph 5.4: Moment Musical No. 4, Harmonic Transformation

A m.1 17 26 31 62 73 89 97 A 115 131 140 145 Coda 176 178
 C#m EM AM C#m DbM FbM FbM DbM C#m EM AM C#m DbM C#m
 (C#M) (EM) (EM) (C#M)

and dreamy illusion. The harmonic transformations of this piece are provided on Graph 5.4. The opening C# minor modulates to its relative major (E major) through measures 16 and 17. The E major continues on to A major at measure 26. The opening theme comes back at measure 31 in the tonic key, C# minor, over a modified left-hand accompaniment. It stays in the same key for a while until the B-section comes in at measure 62. The modulation from C# minor to Db major between A and B sections is through an enharmonic transformation; this modulation, from the sharp-key to the flat-key, can be simply understood by treating the Db major as C# major enharmonically. (The C# minor transforms to its parallel key, C# major (= Db).) At measure 73, the piece arrives at F flat major temporarily. This F flat major can also be treated as E major enharmonically; treating it as E major is more natural and understandable, if we treat the preceding key as C# major and if we consider the fact that the E major is one of the main key areas in the A-section. (On graph 5.4, the enharmonic transformations are marked with slurs.) After these enharmonic transformations in the B-section, the piece modulates back to the opening C# minor at measure 115, with the return of the A-section. At the coda, the middle section's theme in Db major reappears for a moment, but suddenly returns back to C# minor to conclude the piece. This unique ending not only reviews the contrast

between the major and minor modes used in the preceding sections, but also represents the wanderer's contrasting emotions. Right before the coda, the C#-minor phrase suddenly stops at measure 174 without a cadence. After the measure-long silence, the Db-major theme from the B-section is revived for a moment, like the happy memory recalled in the wanderer's heart, but the C# minor comes back suddenly and the transient dream is faded away and the wanderer is now dragged back to reality (the score of the coda is provided below, Example 5.9).

Example 5.9: Moment Musical No. 4 (mm. 176–180; coda)

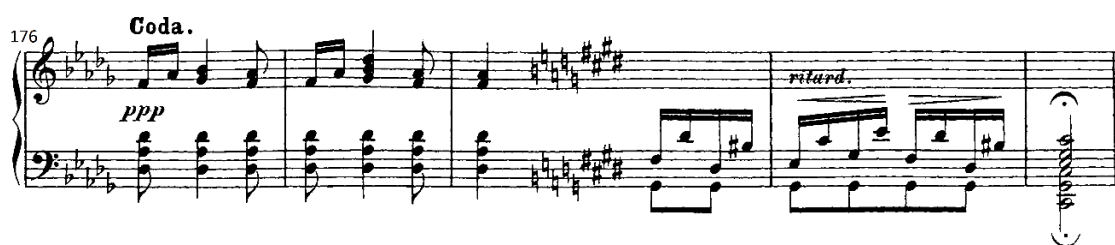

The *Tonnetz* graph of this piece is attached on the next page. As I mentioned before, the middle section's flat keys, Db major and Fb major, should be enharmonically treated as the sharp keys, C# major and E major, so that the transformation between the A and B sections becomes more comprehensible. By doing so, the *Tonnetz* graph emphasizes the closeness of the keys between the sections. Having C# minor, the piece's opening key, as a center, the other keys are placed next to its sides, surrounding the C#-minor. Even though the contrast between the major/minor modes of the sections is obvious, the *Tonnetz* graph emphasizes the close relation and number of common tones between these key areas. The wanderer's conflicting emotion, in his reality and in his

dream, is still there, represented by the contrasted major/minor modes and musical textures, but the closeness of these key areas on the graph, and the common tones that closeness represents, suggest that the wanderer’s conflicted sentiments between reality and illusion are actually close to each other, like two sides of the same coin.

Tonnetz Graph 5.4: Moment Musical No. 4 (D. 780-4)

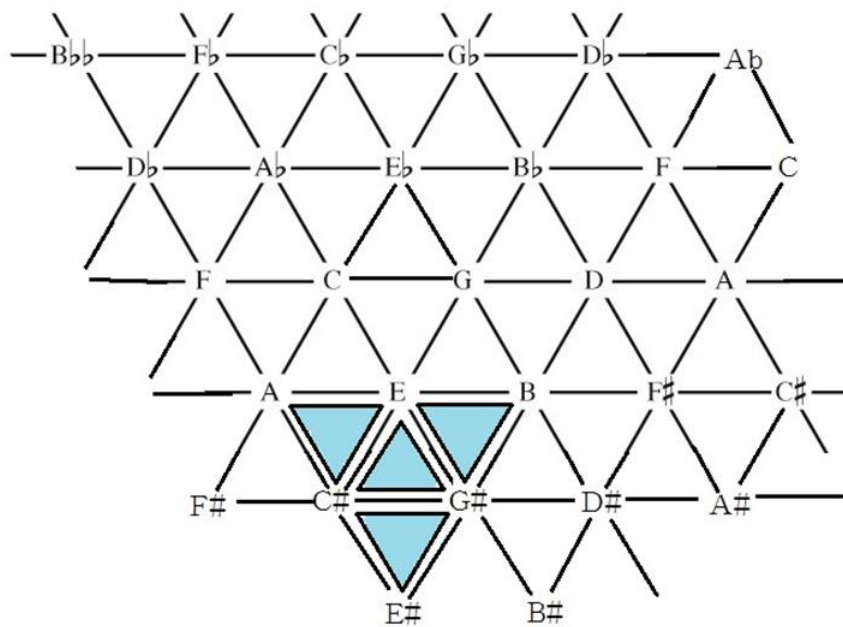

Moment Musical D. 780-No. 5 in F Minor

Moment Musical No. 5 is a short piece in F-minor. The characteristic of this piece is its regular dactyl rhythm (long-short-short) used continuously throughout the piece. As I mentioned in the previous chapters, the dactyl rhythm is one of Schubert’s favorite motives to express the nature of human life and death as “wandering” (since long-short-short rhythm gives us a sense of the heavy walking of a wanderer, depending on the

tempo), as we see it in his song “Der Wanderer” D. 489 and the piano work “Wanderer Fantasy.” The other significant feature of this piece is its frequent changes of key, especially in the middle section. In the opening section, F minor temporarily modulates to Db major through measures 15–18, but returns to F minor soon after. The Db-major harmony comes back at the beginning of the middle section. Right after the arrival on Gb major, the rhythmic texture changes and a sequence of 4-measure+2-measure phrases begins at measure 34. From there, modulations occur every 6 measures (Gb major→B minor→C minor→C major.) The dactyl rhythm comes back at measure 58, and the piece returns back to F minor. The returning A section, in F-minor, turns suddenly to F major at the end, similar to the epiphanic modulation we heard in Moment Musical No. 2 (see pages 111–112 for details.) Just as in Moment Musical No. 2, the sudden change from the minor mode to its parallel major seems to represent transformation from a gloomy mood to a peaceful dream in the wanderer’s sentiment. The harmonic modulations in this piece are portrayed on graph 5.5 below.

Graph 5.5: Moment Musical No. 5, Harmonic Transformation

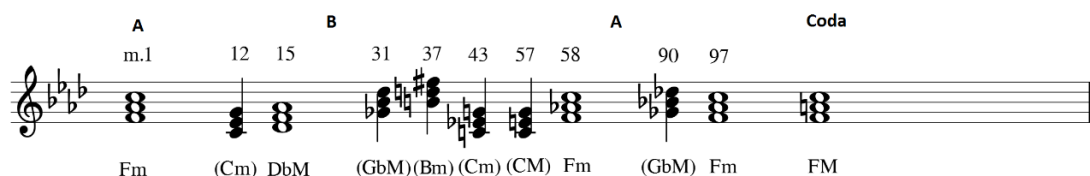

The main harmonies used in the piece are mapped on the *Tonnetz* graph on page 121 (*Tonnetz* Graph 5.5). The opening key, F minor, is centered between the other main

key areas, Db major and F major, sharing two common tones with them. The placement of these three key areas on the graph looks very similar to the *Tonnetz* of Moment Musical No. 3, since both pieces start in F minor and end in F major. The only difference is the modulation to Db major, while Moment Musical No. 3 contains a modulation to Ab major instead. The temporary key areas, marked by the triangles only with the frames, are placed distantly and separately around the main key areas. Those key areas separately placed around the main keys describe the wanderer trudging around different lands, while the parallel relation between the F major/minor is also seen on the graph—these chords are placed next to each other, representing the wanderer’s conflicted but closely tied emotions.

Tonnetz Graph 5.5: Moment Musical No. 5 (D. 780-5)

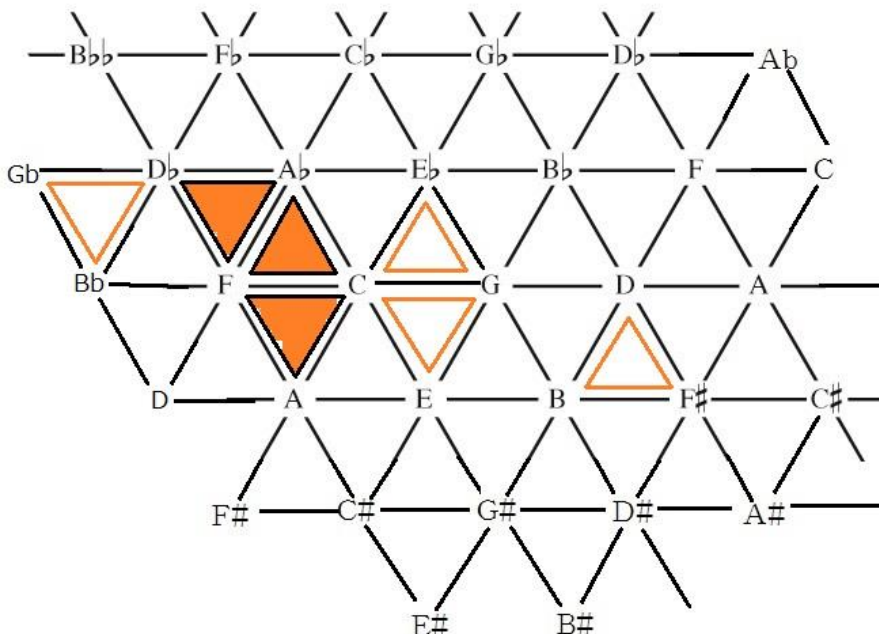

Moment Musical D. 780-No. 6 in A-flat Major

The last piece of the set, Moment Musical No. 6, is in Ab major. Of the six pieces in the set, Moment Musical No. 6 is the only piece that begins in a major key and ends in the minor mode. This piece seems to share common features with the other Moment Musical in Ab major (No. 2); as I discussed at the beginning of this chapter, they are alike in their opening keys, their chromatic modulations (see pages 102–103 for details), and their textures consisting of unbroken chords. But the modulation to the parallel minor at the end of No. 6 is the main feature that makes it dissimilar to No. 2. The final cadence in Ab minor at the last bar gives us somewhat of a sense of un-anticipation and uncertainty—we get this sense because the preceding phrase in A-major (from measure 71) suddenly transforms to Ab minor (at measure 74) to conclude the piece (the score of the ending is provided on the next page, Example 5.10). In Moments Musical No. 2 and No. 5, we have seen the epiphanic modulations, the transformative “Moment Musical,” where the minor mode suddenly changes to major mode. The Moment Musical No. 6 concludes with a sudden modulation which is very much like those epiphanic modulations in other pieces, but this time the modulation is from major to minor mode. As the conclusion of the whole set, this ending in minor mode and its feeling of instability and ambiguity may portray the wanderer’s journey which comes to its end, but the wanderer’s mixed feelings are not resolved and his hopelessness is never dispelled. Also, in the piece, this ending is the only place where a perfect cadence in minor mode appears. So, this minor ending contrasts enough with the major modes of the main section and the Trio, representing the wanderer’s illusion (described by the major modes) finally fading away, and his dismal reality, or his inevitable motion toward death (represented by

the final minor ending), as the only destination he can reach.

Example 5.10: Moment Musical No. 6 (mm. 68–77; ending in Ab minor)



Graph 5.6: Moment Musical No. 6, Harmonic Transformation

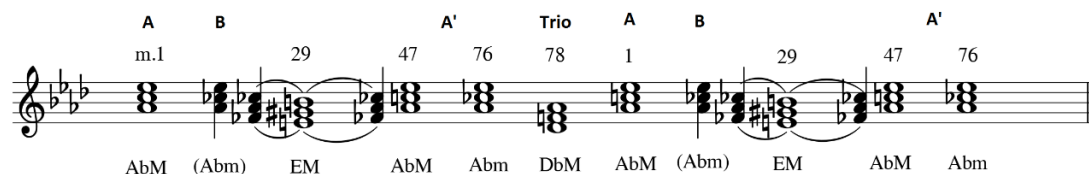

Graph 5.6 above describes the harmonic transitions of No. 6. A *Tonnetz* graph is also attached on the next page. The opening section consists of an 8 measure + 8 measure period in Ab major. At the beginning of the following section from measure 17, the piece attempts to modulate to Ab minor, but this attempt seems insufficient, due to its lack of a complete cadence; instead of resolving to a cadence in Ab minor, it suddenly transforms to E major at measure 29 through the enharmonic modulation. After the E-major cadence at measure 39, it transforms back to Ab major through enharmonic modulation again. The opening theme comes back at measure 54; in this returning A section, instead of having a cadence at the end of the period, the music implies a modulation to A major at measure 66. But, this modulation does not resolve in A major, but continues on to Ab minor

instead. These imperfect overlapped modulations and the lack of complete cadences give us a sense of searching for true ending, just like the wanderer searching for a place to end his journey. This is very similar to the musical setting of the opening section of the fourth impromptu D. 899, where the wanderer's searching for his home is represented by the same theme repeated over and over in different keys, giving us a sense of searching for the true beginning (see pages 94–96 for details). In *Moment Musical No. 6*, by omitting the complete cadences and stringing together imperfect modulations, the composer seems to depict the wanderer who searches for the final destination of his journey.

Tonnetz Graph 5.6: *Moment Musical No. 6* (D. 780-6)

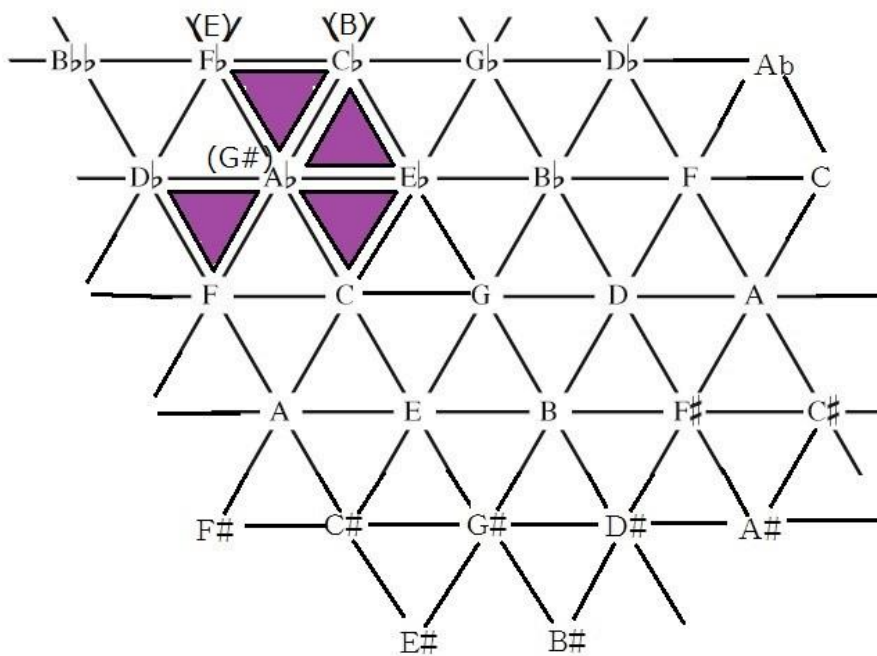

The *Tonnetz* graph of the entire work (D. 780) is attached on page 126. (*Tonnetz* Graph 5.7) Like the *Tonnetz* graph of D. 899 in chapter 4, the different colors signify the

different movements. (No. 1; colored in pink, No. 2; colored in yellow, No. 3; colored in green, No. 4; colored in blue, No. 5; colored in orange, and No. 6; colored in purple.) The important chords and key areas covered in all six pieces (D. 780, Nos. 1–6) are included in this graph. As we see here, the large reversed-triangle configuration, which we saw in the graph of the Impromptus D. 899, appears again in this graph.

Moments Musical associates with the concept of the wanderer in some ways.

Firstly, the major/minor modes represent the contrast between the wanderer’s dream and his reality. The contrast between major and minor modes is notably seen in every piece of the set. Sometimes the transformation between major and minor mode happens suddenly, like the epiphanic modulations in No. 2 and No. 5. Those moments in which major/minor or minor/major modulations happen may be the transformative “Moments Musical,” when the wanderer’s dream and reality intersect in his mind. Those moments are the representations of the wanderer’s struggling sentiments and his life existing between dream and reality. The F# minor appearing in Moment Musical No. 2 especially represents the wanderer’s feeling of alienation, as Charles Fisk suggests. The *Tonnetz* graph describes such a feeling of alienation by placing this key outside the triangle configuration. Secondly, as Fisk has shown, in the relation between the ABABA formal structure of Moment Musical No. 2 and Schubert’s allegorical tale “Mein Traum,” the formal structure of the piece represents the wanderer’s life journey. The story of “Mein Traum,” the protagonist’s alternate homecoming and exile, corresponds to the cyclic ABABA structure of No. 2. Also, not only this individual piece, but also the whole set is in its own way cyclic. The cyclic order of the tonic keys—C-Ab-F-C#-F-Ab-(C), that I mentioned at the beginning of this chapter (see page 101, diagram 2), ties together

Tonnetz Graph 5.7: Moments Musical D. 780 (Nos. 1–6)

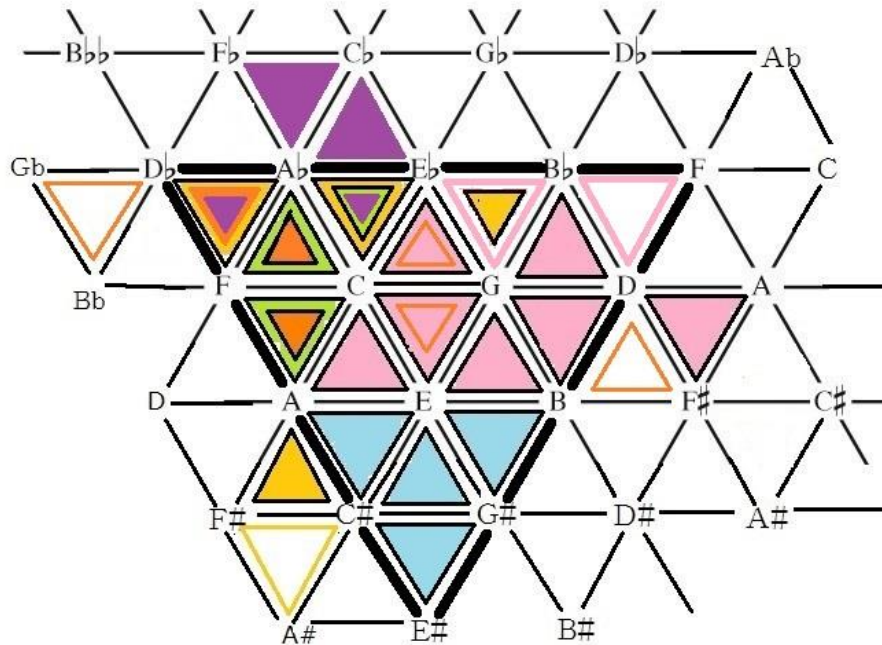

the entire work. These cyclic formations accord with the concept of wandering, which I discussed in chapter 2—the eternal circulation between life and death. The circulation between life and death, which Schubert portrays within the cyclic formation of *Moments Musical*, is geometrically represented by the reversed triangle configuration on the *Tonnetz* graph.

The *Tonnetz* graph 5.8 on page 127 describes how the principal keys shift within the triangle configuration, using arrows 1–6. The first movement starts in C major, which is placed at the center of the triangle. Then, the key-shift goes through $Ab \rightarrow Fm \rightarrow C\#m$, and then goes back along the same course $C\# \rightarrow Fm \rightarrow Ab$. But the work never returns back to its opening key, C major—the work ends in Ab minor instead. (Instead of returning back to the triangle’s center, it ends on the key placed outside the

configuration.) It seems to me that this circulated path within the triangle, which starts at the center but never returns to there (even goes outside of the configuration at the end), visually represent the wanderer’s path through his journey—he left his home, and as his journey goes on, his feeling of alienation is intensified and his home becomes more distant from him.

Tonnetz Graph 5.8: Moments Musical D. 780, Shift between the principal keys

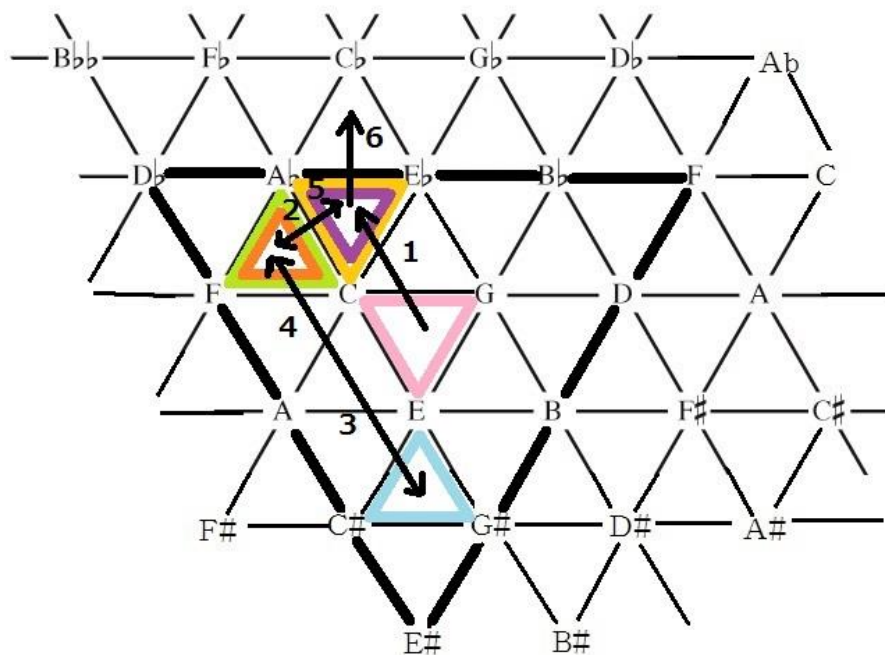

Schubert composed a poem titled “Die Zeit (Time)” in 1813. (See page 8 to read the entire poem.) The first two lines of the third stanza—“But a sound! —for such is Time. Let this sound be music’s treasure.”—is Schubert’s aphorism. For him, a moment in time and a moment in music are both precious. This work, *Moments Musical D. 780*, may reflect Schubert’s thoughts about valuable moments of his life and music. Through

the moment when the major mode turns to minor, or through the moment when the transition between the contrasting sections occur, *Moments Musical* illustrates life's various moments—the moment when reality turns to dream, the moment when pain turns to love, and the moment when life turns to death. These moments together form a human life, the eternal cycle between life and death.

CHAPTER VI

SONATA IN C MINOR, D. 958 (1828)

Schubert composed his C-minor sonata, D. 958, in 1828, the year of his death. Anton Diabelli purchased the autograph of this work from Ferdinand Schubert (Franz Schubert's brother) in 1829, and published it in 1839. This piano work is one of his last three sonatas, written just a few months before his death. Since these sonatas were composed around the same time, they are considered as a set. John Bell Young writes that "while it seems likely that Schubert's dying wish was to have all three published as a set, the conviction that they were intended as such comes largely from twentieth-century scholars. Beyond their coinciding dates of composition, there is at least one more bit of evidence in support of this contention: Schubert explicitly put in a request to Probst to dedicate all three to another of his heroes, the composer Johann Nepomuk Hummel" (Young 2009, 127–128). Also, the fact that Schubert labeled these three works as Sonatas I, II and III supports the idea that he regarded them as a set. The interconnections between these three sonatas have been described by several scholars. Young writes: "what are significant are the innumerable motivic and harmonic strategies that collectively inform these works in an orgy of self-referential material. As one movement or sonata looks back upon another within or outside of itself, varying, citing, or merely recycling this or that melodic fragment or rhythmic gesture, the music assumes a stature that cannot be claimed, at least with such deliberate fecundity, by his earlier piano music. The last three sonatas, for all they have in common structurally and otherwise, speak to a greater truth as they give form to what might be properly described as a megasonata" (Young 2009, 128).

Schubert's C-minor sonata shows the influence of Beethoven's Variations in C minor, WoO 80. The opening phrase of Schubert's piece is almost identical to Beethoven's theme. (Both are shown on p. 132, Examples 6.1 & 6.2.) For this reason, the C-minor sonata has been compared to Beethoven's variations by a number of music scholars. Also, the association of Schubert's sonata to Beethoven's sonatas has been discussed often.

While correspondences between Schubert's and Beethoven's pieces are certainly there, Schubert's theme seems even more powerful than Beethoven's. Charles Fisk claims that "Schubert begins by making Beethoven's theme more Beethovenian than Beethoven himself made it—or, at least, more like the opening of a dramatic Beethoven sonata. He simplifies the melodic beginning, eliminating the syncopation that initiates the melody in Beethoven's theme. He also transfers the descending chromatic motion of Beethoven's bass to an inner voice, underpinning that erstwhile bass with a tonic pedal that, along with the thicker chords, imparts to his theme a more massive cast" (Fisk 2001, 181). Also, Schubert's opening chromatic ascent creates more of a sustained dramatic effect than Beethoven's. In both Schubert's and Beethoven's opening themes, the long measure-by-measure ascent initiates with the pitch E-natural and arrives to Ab as the high-point of the melodic ascents. In Beethoven's theme, the arrival to Ab seems to come too soon—Beethoven creates the ascending melodic steps through the first five measures (C-D-E-F-F#-G), but the arrival of Ab (within the F-minor harmony) at measure 6 terminates the ascending motion, and the following two measures involve the simple cadence in unison without any chordal support. In contrast, Schubert arrives at Ab for the first time at measure 7, but the conclusive arrival to Ab is extended until measure 12—this Ab an

octave higher in fortissimo comes as the arrival of the opening ascent and as an initial pitch of the following long descending Ab-major scale. Fisk describes Schubert's use of this powerful and dramatic arrival of Ab as follows;

The Ab waits its turn in measure 7, and then gets it only provisionally, as a quasi-dissonant appoggiatura leading to a half cadence. The gesture is intensified even more the third time; now the high tonic replaces Ab as if to leave it behind. Where a third half-cadential dominant might be expected (measure 12), Ab suddenly and imposingly returns, usurping the place of the dominant. As if through sheer force of will, it makes a weak measure into a strong one, superimposing its own tonal and metrical order on the one already established. After the leap up to this high fortissimo Ab, an Ab-major scale rushes down through four octaves like a violent gust of wind, filling up two full measures and most of a third. This three-measure gesture, so registrally and dynamically emphasized, disrupts not only the regular alternation of strong and weak measures that precedes it but also the organization of the entire theme before its arrival into two-measure groups. The disruptive force of this descent has the effect of immediately tonicizing the Ab, of wrenching the music into this key and thus of suddenly collapsing the momentum toward a C-minor cadence. (Fisk 2001, 182)

Although Beethoven's theme is unusual and innovative, compared to works composed by other classical composers in that period, Schubert's opening theme is much more dramatic and dynamic, for its extension of the Ab-arrival, its use of wide-ranging registers, its sudden modulation to Ab major after the long ascent, and its following long descending scale in Ab major.

Example 6.1: Schubert, Sonata in C minor (D. 958), first movement, mm. 1–16

Allegro

1 *f* *cresc.* *ff* *p* *cresc.*

Example 6.2: Beethoven, 32 variations, WoO 80, mm. 1–8

THEME

Allegretto

PIANO

1 *f* *ben tenuto* *sf* *p* *Pd.* *

While Schubert's great respect for Beethoven and the influence of Beethoven's pieces upon Schubert's is well known, we should also turn our eyes to Schubert's own ideas, especially those regarding human life and death, that are expressed in his Sonata in C minor. Fisk points out the C-minor sonata's many associations with the song cycle *Winterreise*. He writes that the first two movements of the sonata recall *Winterreise* through their musical parallels; 1) the development theme in the first movement recalls "Erstarrung" and "Der Lindenbaum," 2) the opening theme of the Adagio reminds us of "Das Wirtshaus," 3) the third subphrase in the opening theme of the Adagio recalls "Gefror'ne Tränen," 4) the following episode just after the subphrase recalls "Gute Nacht," "Auf dem Flusse," "Der Wegweiser," and "Einsamkeit." These correspondences give us a sense of searching and self-discovering through the image of the protagonist portrayed in the story of *Winterreise* (Fisk 2001, 192). These connections between the Sonata and *Winterreise* songs, which I will discuss later in this chapter, suggest that Schubert's thoughts about death and the concept of wandering are also expressed in his C-minor Sonata. By reflecting the protagonist of *Winterreise* in his sonata, Schubert portrays the wanderer's searching for home and for meaning to live. Although the protagonist's journey proceeds toward death, his journey also signifies a process of self-discovery through contemplating his origin and his life.

The final movement of the Sonata is a tarantella, similar to Schubert's string quartet D. 810 "Death and the Maiden," which features the theme of the "dance of death." Since "Death" is portrayed in the quartet as a character who embraces and relieves the maiden who is in fear, we should regard Schubert's tarantella, the dance of

death, as a depiction of salvation and eternal rest given by death. In this sense, the C-minor sonata is the music in which Schubert expresses his notion of death as resurrection. Not only as an artist but also as a wanderer who struggles with his own journey toward death, Schubert depicts his own conception of death that goes beyond fear of destruction to a hope for rest and everlasting life.

Beethoven's death was only about a year before Schubert composed this sonata—for this reason, it is natural that we assume that Beethoven's death motivated Schubert to work on this composition. However, in this sonata, Schubert presents his own conceptions of wandering toward death, beginning his journey by walking away from the “father figure” Beethoven, and by incorporating memories of *Winterreise* and the dance of death. (The similar relationship, composer's relationship with the past, is discussed in Straus's *Remaking the Past*.)⁴ By focusing on his own conception of death in this sonata, Schubert reconsiders his own life. He portrays himself as a wanderer who leaves his Beethovenian home.

Sonata in C minor D. 958, First Movement (Allegro)

The first movement, which begins with the Beethovenian passage, is in a dark, energetic, and somewhat violent mood. As I mentioned at the beginning of this chapter, the opening Beethoven-like theme goes through a chromatic melodic ascent, which arrives at the high Ab at measure 12. This arrival on Ab is the moment where the piece's

⁴ Straus discusses composers' ways of establishing a relationship with the past and separating themselves from it. He uses Stravinsky, Schoenberg, Bartók and Berg to illustrate. He introduces Stravinsky's own words “the true business of the artist is to refit old ships,” discussing composers' reactions to musical predecessors. For more details, see Joseph N. Straus, *Remaking the Past*, 1990.

first modulation happens (modulation from C minor to Ab major), and this moment leads into a long descending Ab-major scale for the following two measures. The appearance of this Ab-major harmony not only dramatizes the opening theme, but also makes it proceed easily to the second theme in Eb major. The tranquil music of the second theme from measure 39 contrasts with the violent opening theme. (The score of the second theme is attached on the next page, Example 6.3.) Fisk describes the second theme as follows; “in the recent memory of the sonata’s opening strife, the second theme comes as a vision of calm, sheltered from the first theme’s conflict, although it is not without an inner striving of its own. In contrast to the aggressive chromatic upward striving of the first theme, however, this theme sways tranquilly, diatonically rising and falling in gentle waves without strong accents or dotted rhythms” (Fisk 2001, 184). At measure 46, an Eb dominant seventh chord suggests a modulation to Ab-major, but a Ab-major cadence does not come. Instead, Db-major harmony suddenly appears in measure 48, which implies a modulation to either Db major or Gb major; but soon after, it returns back to Eb major at measure 53.

The second theme in Eb major is a basis for the variations that follow it. Fisk writes that “whereas, for Beethoven, the precursor of Schubert’s opening theme served as a theme for variations, it is Schubert’s second theme, this new theme of his own, that now becomes a basis for variations of a very different sort” (Fisk 2001, 185). The variations on this second theme appear several times in different keys; the first variation begins at measure 54, which is in the same key, but with the melody played in octaves and accompanied by the left-hand triplets; the second variation comes at measure 68 in Eb

Example 6.3: Sonata in C minor (D. 958), first movement, mm. 36–55

36

2nd Theme

f *fz* *p* *ligato*

42

cresc. *pp*

50

(1st Variation)

cresc. *p*

minor and in Gb major at measure 72 (the same variation is repeated in different keys sequentially). Fisk points out that this Gb major is the “delayed resolution” of the Db-major harmony appearing in the second theme. The third and final variation, the culmination of this section, starts with an Ab-minor harmony at measure 77, and modulates to Eb major, concluding this section.

After the cadence in Eb major, the closing theme appears at measure 85. Fisk writes that this closing theme recalls the “very moment of the transition (m. 27) that, through the Ab harmony as subdominant, opened the way from C minor to Eb major. This closing theme, like that transition, melodically outlines a descent by step from (scale degrees) 6 to 3. In making minor the major subdominant to which it refers, this theme signals once again the inability of the second theme to realize itself through a diatonic

resolution in Eb major and, thus, the unattainability, for now, of the calm-after-resolution that that major subdominant might potentially bring” (Fisk 2001, 186).

The development section from measure 99 starts with the aggressive Ab-major chord. Just like the Ab-major descending scale in the opening theme that contrasts with C minor’s dark atmosphere, this Ab-major chord creates a contrast between the development and the opening section. Also, the opening theme’s chromatic ascending movement reappears here from measure 103 to 109 in the bass line (Ab-A natural-Bb-B natural-C.) This ascending step motion transfers to the right hand from measure 109 (C-Db/Eb-Fb/Gb-G.) At measure 117, the piece modulates to D major. This arrival of D major is dynamically and texturally one of the most emphasized moments in the movement, like the arrival of Ab in the opening section.

What follows this strong articulated D-major arrival is a mysterious chromatic phrase played by the left hand from measure 119. (The score is attached on the next page, Example 6.4.) Fisk claims that this phrase recalls the motives used in several of the *Winterreise* songs and comes like “the oracular voice of a disembodied being” (Fisk 2001, 187). This phrase reminds us of the chromatic motion used in *Winterreise*’s “Erstarrung” as well as the wind motive of “Der Lindenbaum.” With those affinities, this “oracular” motive recalls the image of the wandering lonely protagonist who meanders around the winter wasteland, just like the wanderer depicted in *Winterreise*.

After these phrases that are evocative of *Winterreise*, played below and above the accompaniment, the same phrase is repeated in the bass again from measure 125—this time this phrase incorporates the chromatic ascent, which is much like the opening theme. This chromatic ascent, D-Eb-E-F-Gb-G-Ab, assists the piece to modulate back to Ab-

major. Fisk claims that the Ab-major phrase from measure 131 to 133 is a fusion between the second theme and the development. He writes that “the return of this key occasions a transformed reemergence of the second theme (mm. 131–133), the theme that was so

Example 6.4: Sonata in C minor (D. 958), first movement, mm. 113–124

marked in its original Eb major occurrence by both the presence and the subsequent absence of Ab as a harmony and is now suffused with the chromatic neighbor motions and rhythmic anonymity of the development theme. This drawing of the second theme of the exposition into the net cast by the development theme metaphorically achieves a fusion of the second theme’s Schubertian voice with the mysterious voice disclosed through that new theme, as if the self-assertion and ensuing self-exploration of the

Schubertian persona have prepared it for the possibility of its own dissolution” (Fisk 2001, 189).

The development theme reminiscent of *Winterreise* is now played in octaves in the right hand from measure 134, and is still in chromatic ascending motion. This chromatic ascent, Ab-A-Bb-Cb-C-Db, assists with a modulation from Ab major to Db major. Again, after the arrival in Db-major, the fusion of the second theme and the development reappears in the left hand from measure 140. The return of the development theme in the left hand from measure 142 is accompanied by the mysterious right-hand chromatic line. The chromatic rising and falling line continues until the opening C-minor theme comes back at measure 160.

The harmonic transformation in the first movement is described on Graph 6.1 on the next page. Also, these harmonies are mapped on the *Tonnetz* graph on page 141. As Graph 6.1 and the *Tonnetz* show, the frequent changes of major/minor modes create a clear contrast between different sections or themes, seeming to function as the representation of varying sentiments of the wanderer. Also, on the *Tonnetz*, the arrows colored in brown and grey represent the routes of the harmonic transformations happening in the exposition (brown arrow) and in the recapitulation (grey arrow). These arrows show the circulated path of the harmonies, transforming around the work’s central key C minor, and we can also perceive from this that the transformations in the exposition involve the chords placed above C minor, while the transformation happening in the recapitulation involves the chords below C minor on the graph.

Like the Impromptus D. 899 and Moment Musical D. 780, the contrast between major/minor modes represent the wanderer’s conflicted emotions in his reality and in his

dream. The most apparent contrast is between C minor and Ab major (marked on *Tonnetz*, Arrow 1), which comes in the opening theme. The Ab major, which dispels the opening gloomy mood in the first theme, reappears at the beginning of the development section and at measure 129. Those moments in which the Ab major appear seem to represent a bit of hope rising in the wanderer's dismal mind, like the sun-light breaking through the clouds. On the *Tonnetz*, the C-minor and the Ab-major chords are placed next to each other, but their functions in the piece are opposite. As we have seen on the graphs of other Schubert pieces, *Impromptus* and *Moments Musical*, in the previous chapters, the contrast between major and minor modes is salient, representing the wanderer's contrasted feelings, but those contrasted harmonies are sometimes placed next to each other on the graph, just like the different sides of the same coin. The closeness of these contrasted major/minor modes on the graph is just like reality and dream co-existing in the wanderer's mind, or like life and death linked to each other.

Graph 6.1: Sonata in C minor, D. 958, first movement, Harmonic Transformation

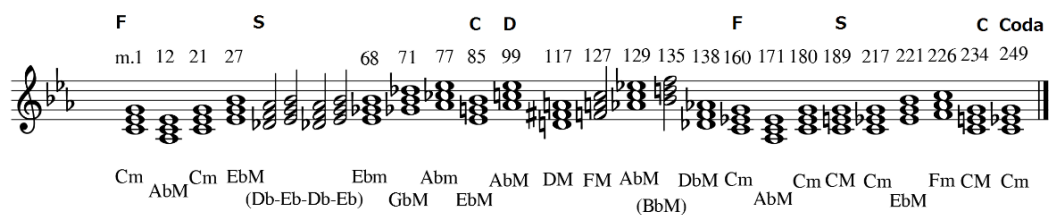

Tonnetz Graph 6.1: Sonata in C minor, first movement (D. 958-1)

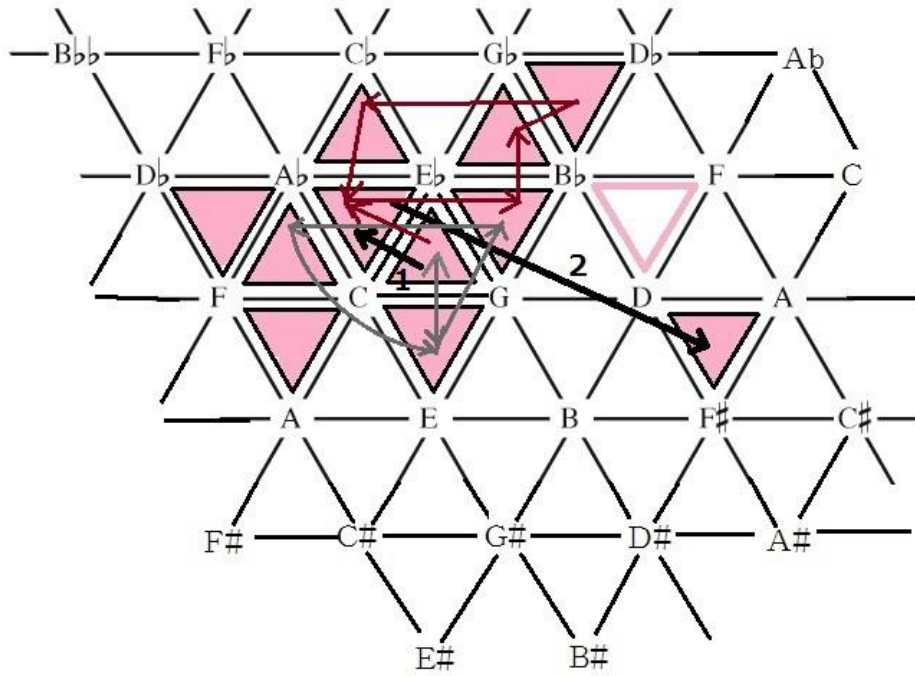

While most of the sonata’s chords are mapped side by side on the *Tonnetz*, the D-major chord is placed distant and separate from them. The D-major chord appears at measure 117, where the strong arrival in that key (the second arrival to Ab major at m. 99 → modulates to D major at m. 117, marked on *Tonnetz*, Arrow 2) is followed by phrases recalling the *Winterreise* songs. Borrowing the chromatic motion from the song “Erstarrung” and wind motive from “Der Lindenbaum,” this D-major phrase sounds like “the oracular voice of a disembodied being” (as Fisk describes it on page 187, 2001). Even though the phrase is in a major-key, from this melody, we do not sense or perceive the traditional image of a Schubertian major-key, such as the feelings of dream, illusion, or hope—this is because the chromatic movement and the use of Eb (the flat-second)

creates a peculiar, mysterious mood. This mysterious ghost-like melody in D major may represent an auditory hallucination that the wanderer hears, in his feeling of alienation, and in the fear of his approaching death. Along with these feelings, the wanderer feels loneliness, more and more recognizing himself as a “Fremd.” The image of alienation that this D-major phrase gives us is reflected on the *Tonnetz* graph, where we see the D-major chord at a distance from the other chords.

Sonata in C minor D. 958, Second Movement (Adagio)

The key of Ab major, which appears in the opening section and development of the first movement, now becomes the opening key of the second movement. We see this same tonality, Ab major, used in the slow movements of Beethoven’s early C-minor sonatas. In Schubert’s sonata, the appearance of this key in the first movement was dramatically and impressively emphasized, enough to cause us to anticipate the return of the key at the beginning of the Adagio. Furthermore, the opening theme of the Adagio shares its basic melodic outline 1-7-1-2-3-4-3-2 with motives used in the first movement, according to Charles Fisk. See Example 6.5 (a, b, c) on the next page to compare the same motive shared between the first and second themes of the first movement and the second movement.

Fisk also demonstrates the association of the second movement with several of the *Winterreise* songs. The most obvious connection is the third subphrase in the opening theme (mm. 9–14, Fisk calls it a “focal progression”, Example 6.6), corresponding to *Winterreise*’s third song “Gefror’ne Tränen.” (Example 6.7) Fisk writes that the phrase

Example 6.5 (a): Sonata in C minor, first movement, mm. 14–15

Musical score for Example 6.5 (a), Sonata in C minor, first movement, mm. 14–15. The score is in C minor (three flats) and 2/4 time. It features a piano introduction with a chromatic descending line in the right hand and a steady bass line in the left hand. A red bracket highlights a specific fingering sequence in the right hand: 1 7 1 2 3 4 3. Dynamics include *fz*, *p*, and *cresc.*

Example 6.5 (b): Sonata in C minor, first movement, mm. 39–43

Musical score for Example 6.5 (b), Sonata in C minor, first movement, mm. 39–43. The score is in C minor (three flats) and 2/4 time. It features a piano introduction with a chromatic descending line in the right hand and a steady bass line in the left hand. A red bracket highlights a specific fingering sequence in the right hand: 1 7 1 2 3 4 3. The word *ligato* is written above the first measure, and the dynamic *p* is written below the first measure.

Example 6.5 (c): Sonata in C minor, second movement, mm. 1–4

Musical score for Example 6.5 (c), Sonata in C minor, second movement, mm. 1–4. The score is in C minor (three flats) and 2/4 time. It features a piano introduction with a chromatic descending line in the right hand and a steady bass line in the left hand. A red bracket highlights a specific fingering sequence in the right hand: 1 7 1 2 3 4 3 2. The dynamic *p* is written below the first measure.

“Ob es mir entgangen, dass ich geweinet hab?” in the song shares the repeated notes, stepwise descent in the bass, and chromatic motion in the middle voices, with the Sonata second movement opening theme’s third subphrase. The repeated notes and stepwise bass

descent in the sonata begin on a different harmony from those in the song—the sonata begins on tonic and progresses to subdominant before returning to tonic, while the song moves from subdominant to tonic. But many other features of the two passages are similar.

John Bell Young also points out the same association between the two passages. Young writes that the “two-bar progression (mm. 11–12 of the sonata) can be viewed, when considered in the context of the song’s text, as a weeping motive” (Young 2009, 136). While these progressions coincide with each other, Fisk also points out the difference in the wanderer’s feelings portrayed by the larger contexts of these progressions. In the song “Gefror’ne Tränen”, the wanderer asks—“Ob es mir entgangen, dass ich geweinet hab? /does it only now come to me that I have been weeping?”, but this question “already incorporates its probable answer” (Fisk 2001, 50).

Example 6.6: Sonata in C minor (D. 958), second movement, mm. 8–19

The image shows a musical score for the second movement of the Sonata in C minor (D. 958) by Franz Schubert. The score is in C minor and 3/4 time. It consists of two systems of piano accompaniment. The first system starts at measure 8 and ends at measure 13. The second system starts at measure 14 and ends at measure 19. The music features a mix of chords and moving lines in both hands, with dynamic markings of *pp* and *mf*.

Example 6.7: *Winterreise*, “Gefror’ne Tränen”, mm. 7–18

7
 Ge - fror'ne Tropfen fal - len von mei - nen Wan - gen ab: ob es mir denn ent -
 gan - gen, dass ich ge - weinet hab? dass ich ge - weinet hab?
 13

The second stanza presents another question from the wanderer—“Dass ihr erstarr zu Eise wie kühler Morgentau? /are you (= tears) then so lukewarm that you turn to ice, like cool morning dew?”. The third stanza then gives a full answer to these questions—“Und dringt doch aus der Quelle der Brust so glühend heiss, als wolltet ihr zerschmelzen des ganzen Winters Eis./ and yet you gush from the well of my glowing hot breast as though you would melt all the ice of winter.” While the song contains the wanderer’s answer to his own questions, the second movement of the sonata seems to be reluctant to give an answer to that question. Fisk writes that “the focal progression, the fermata, and its too slight cadential sequel in the sonata imply a question that can have no readily identifiable answer. The two progressions (in the song and in the sonata) can thus be heard as complementary opposites: both as questions, one carrying its own answer, the other open and enigmatic, suggesting a realm of experience still unknown or unacknowledged” (Fisk

2001, 52).

The E-minor phrase starting in measure 28 of the second movement also recalls some of the *Winterreise* songs (the score of this section is provided on page 148, Example 6.8); the upper neighbor figure in dotted rhythm in measure 29 coincides with the dotted rhythm played by the piano accompaniment at measures 24–26 of the opening song “Gute Nacht.”; a stepwise ascent at measure 30 recalls the opening melody of “Auf dem Flusse” and the cadence that appears in “Der Wegweiser” at mm. 17–19. Also, the triplet sixteenth-note accompaniment of the agitated episode after measure 28 is similar to the triplet accompaniment appearing at measure 31 of “Auf dem Flusse,” and to the dramatic triplet accompaniment for the phrase “Als noch die Stürme tobten” in “Einsamkeit.” The dotted rhythms of this episode in measure 32–35 also recall the opening rhythm of the first movement. All these correspondences to *Winterreise* portray the image of the wanderer’s journey, searching for his home in winter’s cold. Fisk states that “these musical allusions to *Winterreise* allow and even encourage us, in interpreting this Adagio Movement, to draw on the imagery of death and the symbolic death of winter, on the search for final rest or transcendence, and the possibility of their denial. By producing a rift in the music, the focal progression [of the main theme at mm. 11–12] opens not only dark memories but also the possibility of overcoming them and no longer having to live in their shadow. At the same time, a reawakening of these memories recalls the possibility that a way to such transcendence may never be found: the wanderer may become lost again in eternal, restless wandering and diffusion of self, as in the death-in-life of *Winterreise*” (Fisk 2001, 53).

In the second A section, the “focal progression” of the main theme is played an

octave higher from measure 51. (The score is attached on the next page, Example 6.9.) The last four beats of the passage, which arrive at Db major (mm. 53–54), are repeated in the lower register (mm. 54–55) but now conclude with a cadence in D major. Fisk points out that the upward shift of a semitone (from Db to D) and the inclusion of an echo in the lower octave have an enigmatic effect, like “a mysterious, vaguely apprehended being, one that is possibly comforting, possibly threatening” (Fisk 2001, 55). Also, this D-major cadence in low register reminds us of the oracular mysterious D-major phrase appearing in the first movement. After this mysterious D-major phrase, the cadential idea in A major (enharmonically interpreted Bbb major) comes a half-step higher than the original’s corresponding cadential idea (the original was on Ab).

In the returning B section after measure 62, the same theme repeats in right and left hands in different keys, and this sequencing of themes continues until the arrival at F major at measure 78. Within this sequence, a modulation from D minor to its relative major is carried out through the following keys: D minor→Eb minor→F minor→F major. The sudden transformation from F minor to F major at measure 73 is very much like the epiphanic modulations we have already seen in *Moments Musical*. Fisk writes that the appearance of the subdominant chord in F major (Bb-major) on the downbeat of measure 73 “comes like a moment of grace in an awe-inspiring setting as if in a return to the terrain of *Winterreise*” (Fisk 2001, 56). In the returning B section, epiphanic modulations then come at m. 73 and m. 93, the second one right before the third returning A section comes at measure 94; at measure 92, the music implies a resolution to A-minor, but instead it suddenly modulates to Ab-major, the key of the opening theme. These epiphanic modulations from minor to major modes in the returning B section create an

effect by which “the music of the B sections inhabits an extraordinary realm, a realm of thought or imagination encompassing dark memories at one extreme and dreams of release from them at the other” (Fisk 2001, 56).

Example 6.8: Sonata in C minor, second movement, mm. 25–36

25 *fp* *decresc.* *pp*

29 *cresc.* *f* *p*

33 *f* *p* *f* *p* *pp* *ff*

Example 6.9: Sonata in C minor, second movement, mm. 51–55

51 *pp* *p*

In the last A section, the focal progression that is reminiscent of the song “Gefror’ne Tränen,” which was introduced first in the opening measures, appears again in different registers. From measure 104, this focal progression is repeated alternating between low and high registers, modulating through chromatic upward shifts. Like the same progression’s echo in the low register in the development section, these recurrences of the progression in chromatic upward shift evoke the sense of a mysterious, oracular voice from the world of *Winterreise*. In the last A section, the voice leading of the progression involves more chromatic movements, and the feeling of disembodied being becomes stronger. The bass whole-tone descent increases that atmosphere. The last part of the focal progression is echoed in different registers (measures 106–107), and the ascending half-steps and the crescendo give us the image of the oracular voice gradually approaching rather than receding away.

The harmonic transformation of the second movement is presented on the graph 6.2 and *Tonnetz* graph on pages 150–151. On the *Tonnetz*, the arrow 1 shows the transformation from the first A-section to the first B-section (AbM→Dbm). The arrow 2 is the transformation from the second A-section to the second B-section (AbM→Dm). As we see on this graph, Schubert chooses to modulate to D minor in the second B-section, not to Db minor as the first B section does, and its distance from the principal key (AbM) becomes more remote. The remote harmonies between the second A and B sections seem to represent the wanderer’s feeling of alienation more intensified.

It seems that the second movement displays the wanderer’s imaginary world, or illusion, becoming more dominant over reality—in this piece, his imaginary world exists not just as something distant. As the repeated echoes rising chromatically and in gradual

crescendo at the end of the piece show, the oracular mysterious voice of disembodied being gets closer to the wanderer—it seems that the oracular sound does not come from a distant place anymore, but maybe he hears it close by in his mind. Maybe he now knows that the oracular voice actually comes from his own fear or distress.

Graph 6.2: Sonata in C minor, D. 958, second movement, Harmonic Transformation

The musical score is presented on a single staff in C minor. It is divided into several sections with corresponding harmonic transformations:

- Section A:** Measures m.1, 8, 9. Chords: AbM, EbM(Fm-Db).
- Section B:** Measures 18, 19, 28, 32. Chords: AbM, Dbm, EM, Em, F#m, Gm, Cm.
- Section A':** Measures 41, 43. Chords: AbM(Fm-Db-D), Abm.
- Section B':** Measures 57, 62, 66, 70, 73, 82. Chords: AM, Dm, Ebm, Fm, FM, Fm, Gm, Abm, Dbm.
- Section A'':** Measures 90, 94, 104. Chords: AM, AbM.
- (Coda):** Measure 110. Chords: (FbM-CM-DbM-DM-AM), AbM.

Tonnetz Graph 6.2: Sonata in C minor, second movement (D. 958-2)

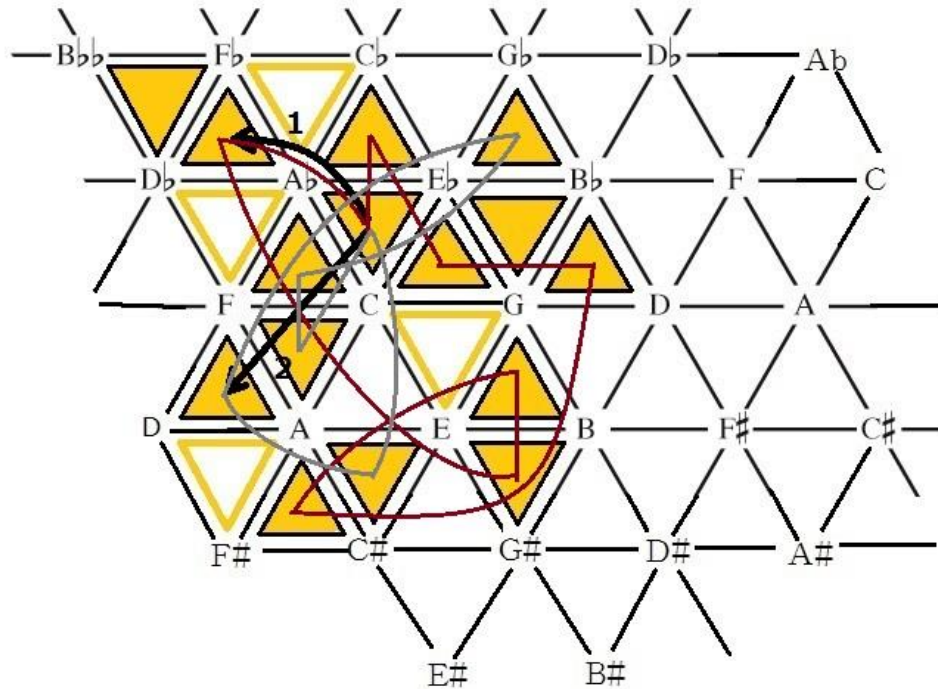

The second movement's association with the *Winterreise* songs is a reminiscence of the image of the wanderer. The protagonist of *Winterreise* continues his wandering journey, within his loneliness, feeling of alienation, and distress. The oracular phrases, which represent the mysterious ghost-like sounds brought to the wanderer by the winds blowing over the *Winterreise*-haunted wasteland, enhance the enigmatic sorrowful mood that occupies this entire movement, even though the piece begins in a major-key. On the *Tonnetz*, the colored arrows (brown and grey) represent the approximate routes that harmonies pass through in the first A/B sections (brown arrow) and the second A/B sections (grey arrow.) Both routes start at Ab major and end on Ab major, and they show the circulating paths of the harmonies around the central key Ab major. But, comparing to the graph of the first movement, where the routes of its two sections are balanced in upper and lower areas, this graph (of the second movement) shows the two routes passing

in a complicated way around the central key Ab major. From this, we can imagine the wanderer who struggles with his mixed feeling of loneliness and alienation here more than in the first movement; like the protagonist of *Winterreise*, whose illusion or dream (represented by Ab major, the key that appeared in the first movement as the key of “hope”) stays in his heart dominantly.

Sonata in C minor D. 958, Third Movement (Menuetto & Trio)

The third movement starts in C minor. Like the first movement, Ab major appears several times through this movement as a counter-key to the opening C minor. The first modulation to Ab major happens in the opening A section at measure 5. The opening section ends in Eb major at measure 10. After the modulation from Eb major back to C minor at measure 20, the second appearance of Ab major comes at measure 22. This Ab major is more strongly emphasized than the one in the opening, by its intervening fortissimo. Fisk claims that this Ab-major phrase recalls the dramatic appearance of Ab major in the opening of the first movement. The hammering Abs and the following leading-tone diminished seventh chord (m. 24) are both emphasized just like the dramatic appearance of Ab major tonality in the opening movement. But the main difference between the appearances of Ab in the first and the third movements is that the Ab in the Menuetto functions to close rather than opening a new section. Fisk also writes that the following phrase from measure 29, the return of the opening theme in the left hand, also recalls the first movement, “especially the last occurrences of its oracular theme in the development (mm. 142 of the first movement)” (Fisk 2001, 195).

The third appearance of Ab major is at the beginning of the Trio, after six beats of

silence. Fisk writes that the Trio recalls the theme of the Adagio mainly because of the chromatic ascent through the harmonic progression from the dominant of Ab to the dominant of F minor (measures 48–49), which is similar to the progression of the Adagio (Fisk 2001, 196). He also claims that the Trio’s dancing rhythm and its legato leaps recall the second theme of the first movement. Starting at measure 54, the Trio’s B section is in Eb major. At measure 61, the Gb played by the left hand creates a temporary modulation to Eb minor. After another temporary arrival on Gb major at measure 67, the section concludes with the Trio’s main theme in Ab major.

The harmonic transformation and the *Tonnetz* graph of this piece are attached on the next page. The harmonic progression is very simple in this piece. The role of Ab major, as the contrasting key to the opening C minor, is highlighted, like the opening of the first movement. The appearance of an arpeggiated Ab-major triad and the following hammering A-flats through measures 21–23 are emphasized to contrast with the preceding phrase and the opening theme in C minor. Ab major, the leading-tone transformation of C minor, which first dramatically appeared in the opening of the first movement, regularly and predominantly appears in the second and the third movements. Like on the graph of the first movement, the conflicted harmonies C minor and Ab major are placed next to each other on this graph although they function contrastingly in the music. Also, on the *Tonnetz*, it is easily perceived that the keys involved in the Menuetto section are placed next to each other, lining up horizontally. (Cm-AbM-EbM, arrow 1) The arrow 2 describes the key transformation in the Trio section, where the Eb minor and Gb major harmonies are joined as the new members. From this, we can visually perceive that the Trio section finds its way to expand the harmonic range and recede away from

the principal key (Cm). It seems to me that the harmonic transformation going away from the principal key represents the wanderer's walking away from his home to more distant places, or his feeling of alienation.

Graph 6.3: Sonata in C minor, D. 958, third movement, Harmonic Transformation

Menuetto						Trio						Menuetto					
m.1	5	10	20	26	29	45	54	61	67	72	1	5	10	20	26	29	
Cm	AbM	EbM	Cm	AbM	Cm	AbM	EbM	Ebm	GbM	AbM	Cm	AbM	EbM	Cm	AbM	Cm	

Tonnetz Graph 6.3: Sonata in C minor, third movement (D. 958-3)

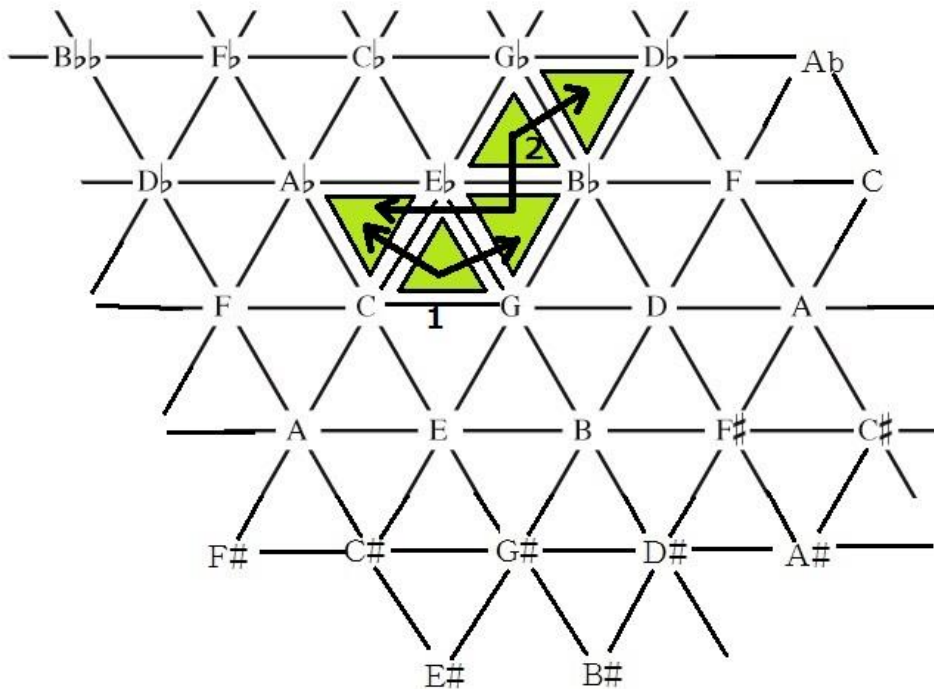

Sonata in C minor D. 958, Fourth Movement (Allegro)

As I indicated at the beginning of this chapter, the last movement is a tarantella, which reminds us of Schubert's string quartet "Death and the Maiden." This quartet is based on Schubert's *lied* with the same title, which was set to Matthias Claudius's poem. In these works, death is depicted as calming down the maiden's disturbance. Below is the dialogue between death and the maiden in the poem.

The Maiden:

Pass me by! Oh, pass me by!
Go, fierce man of bones!
I am still young! Go, rather,
And do not touch me.
And do not touch me.

Death:

Give me your hand, you beautiful and tender form!
I am a friend, and come not to punish.
Be of good cheer! I am not fierce,
Softly shall you sleep in my arms!

As we see, death in this poem is not portrayed as evil, or as the maiden's enemy. Instead, death is characterized as the maiden's "friend," relieving her fear and anxiety. We assume that the tarantella, the dance of death, therefore, represents death as salvation. Fisk says that the music of this sonata suggests "a consequent ability to embrace death without feeling annihilated by the prospect of it" (Fisk 2001, 197). Perhaps, Schubert composed this final movement as a dance of death, to show the possibility of salvation or redemption through death, giving hope to the protagonist of *Winterreise*, who continues to wander in dismay. In *Winterreise*, the final destination that the wanderer proceeds

toward is his death—but for him, death means not just the fear of his downfall, but also it relieves him and leads him to eternal rest.

Starting in C minor, the opening tarantella modulates to Db major first at measure 29, anticipating the appearance of this key later, at the transition. Db major appears predominantly in the first section, like Ab major in the first movement. The tonicization of Db major involves a formal expansion (mm. 29–34, 4 measures + 2-measure expansion), and the prolongation of this expansion (from m. 39), and finally the Db major and minor climactic phrases from measure 49. The opening theme comes back at measure 67 in C major. From measure 86 to 92, the final measures of the temporary C major section, Db still appears as a kind of embellishing tone (upper neighbor of C). These anticipations of Db major through the first section prepare for the transition in that key, in m. 93. Fisk writes that the transition in Db major is a reminiscence of the Ab appearance in the first movement (Fisk 2001, 199). The ascending Db scale here is just like the downward rushing Ab major scale in the opening movement. Also, the following emphasized D-flats and the dotted rhythm (mm. 97–98) recalls the opening rhythmic motion of the first movement.

From measure 113, the pitch Db which was predominantly used in the first section now turns to C# enharmonically, through a modulation from Db major to C# minor. The B-section in C# minor begins with the tonic-subdominant-tonic progression. This B-theme is repeated with chromatic embellishments from m. 129, and this repetition recalls the threatening chromatic gesture which was used in the first movement (from m. 142 of the first movement). The B-section's climax is its end in Eb minor, with a more dramatic version of the main theme of the section. This Eb minor transforms to the Eb major of the

following closing theme from measure 213. At measure 243, after a two-measure silence, the B-major theme ushers in a completely different atmosphere to begin the development section. Fisk claims that this B-major theme is the blend of the melodic motive from the closing theme and the rhythmic figure that the opening theme uses (scale degrees 5-3-2-1) (200). This B-major section closes with a downward-moving scale for four measures, proceeding to the next section of the development. Controlled in its harmony and melody by the left hand, this new section (from m. 305) consists with the same theme repeated in different keys. Each of these phrases begins with the same dactyl motive, and reminds us of the repeated use of the focal progression in the Adagio. The fifth of these repeated phrases extends its length to fifteen measures (from measure 353), and this extended phrase is repeated again at the same length (from measure 368). These repeated phrases constantly modulate: from Db major to Ab major to Eb major.

An arrival in C minor (measure 395) is followed by chromatic ascending scales played by right and left hands alternately, like waves. At the conclusion of these alternating scales, we find a long descending scale in G major from measure 413, which is similar to the B-major scale we saw right before the development theme. These descending scales in this movement recall the dramatic gesture of the Ab-major scale in the opening of the first movement, implying an approach to the recapitulation and the ending of the work. Contrasting to the Ab-major scale of the opening movement, this G-major descending scale is much more simple, functioning as the closure of the preceding section as well as the dominant of the C minor which arrives in a few measures. Ab, which predominated in the first movement, is used at measure 421, but now just as a chord-tone of Db minor harmony, not as a controlling element. What follows this

transition is the recapitulation: the return of the opening C-minor theme, proceeding to the second and closing themes, and the coda which is the very ending of this whole work.

The harmonic transformation of this movement is described on Graph 6.4 and the *Tonnetz* graph on pages 159–160. The arrows describe the transformations between the principal keys of the formal sections. The black arrows present the transformation between the first theme and the second theme (arrow 1) and between the second theme and the closing theme (arrow 2). The brown arrows describe the transformations between the F, S, C themes in the recapitulation. As we see here, the transformations between the principal keys in the exposition ($Cm \rightarrow C\#m \rightarrow EbM$, presented by black arrows) and the transformations in the recapitulation ($Cm \rightarrow Bbm \rightarrow CM$, presented by brown arrows) are equally distanced and symmetrically identical on the graph. In my analysis of the second movement, I mentioned that the harmonic distance becomes gradually more remote as the piece goes on, comparing the first A/B sections and the second A/B sections. In this last movement, comparing the transformations of the exposition to that of the recapitulation, the harmonic distances are visually identical to each other on the *Tonnetz*. It seems that this reflects the wanderer's emotion changing through his journey—in the second movement, more and more remote harmonic distance represents the wanderer's feeling of alienation and his fear toward death increasing in his heart. But in the last movement, the symmetrically equal harmonic distances on the graph represent his fear gradually relieved, as he now knows that death also means salvation. The wanderer travels a circular path closer to the center of the *Tonnetz*, C major, perhaps representing death as a kind of “homecoming.”

Graph 6.4: Sonata in C minor, D. 958, fourth movement, Harmonic Transformation

F **S** **C**

m.1 29 35 49 53 67 93 113 125 129 141 145 149 157 161 169 173 177 182 197 213 217

Cm (Ebm) Dbm CM C#m EM C#m AM Am CM Cm EbM GbM GbM EbM CM
 DbM Fm DbM DbM Ebm Ebm Ebm

D **F**

227 231 237 243 257 275 287 309 315 323 325 341 359 368 374 382 389 395 413 429 453 479 493

EbM EbM BM F#M BM EM Em AM GM Cm Fm DbM Fm Cm Cm Cm CM DbM BbM
 CM AbM EbM GM

S **C** **Coda**

499 511 515 527 531 535 543 547 551 555 559 563 599 603 613 617 623 627 661 673 679 693 697 705

Bbm Bbm F#m AM Am CM Am EbM CM AM CM AM CM Cm DbM Fm Dbm Cm
 DbM GbM Cm Cm AbM (Ebm) DbM

Tonnetz Graph 6.4: Sonata in C minor, fourth movement (D. 958-4)

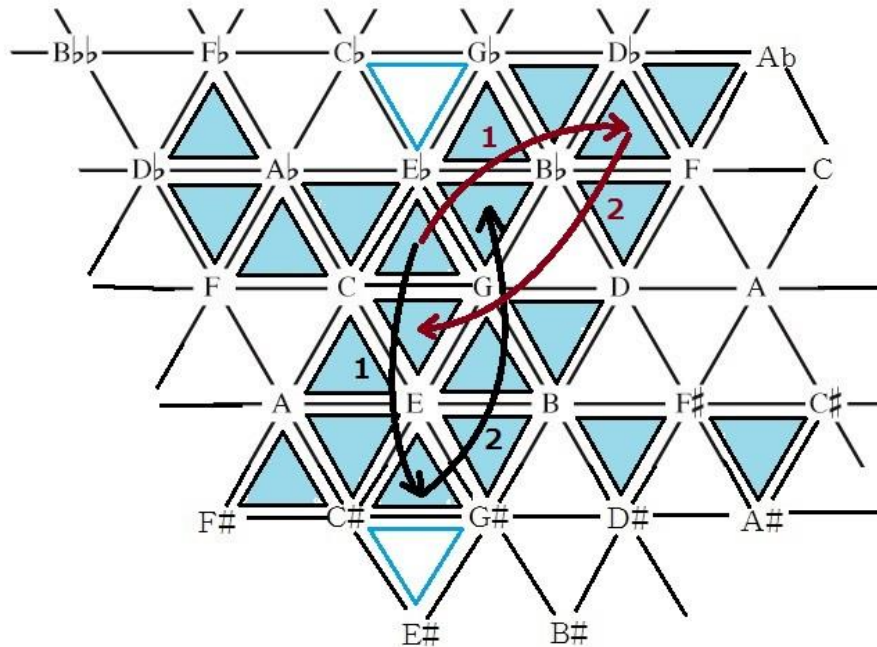

The *Tonnetz* graph that describes the harmonic transformations of the whole sonata is attached on page 162 (*Tonnetz* Graph 6.5). The C-minor sonata is a work that intimately reflects the image of the wanderer and death, through its associations with several of the *Winterreise* songs and its use of the tarantella, the dance of death, in the last movement. In this work, passages that coincide with the phrases from *Winterreise* songs, mysterious ghost-like phrases, and eerie chromatic ascents are used throughout to express the wanderer’s fear and dismay as he faces approaching death. On the other hand and in contrast, the last movement’s tarantella represents death as salvation. Perhaps, this last movement, which describes death as a relief, reflects Schubert’s own conception toward death—Schubert, who struggled with his own fear toward death, identified himself as a

wanderer, reflecting himself in the story of *Winterreise*, and composed this last movement to give himself hope. In this sense, the entire work D. 958 depicts the wanderer's journey, through all four movements. And at the same time, this is also a depiction of Schubert's own life journey—the work expresses his view of life and death, describing the course that he passed through, where he wanders through his fear of death but accepts his own approaching death as a salvation. The *Tonnetz* graph 6.5 reflects such a view of life and death. In this sonata, the opening C minor comes back several times throughout the work as if it represents the wanderer's repeated homecomings and exiles. The C-minor harmony is placed almost at the center of the triangle configuration, and it seems to me that C minor, together with C major, is the center of the wandering, the wanderer's home that he recalls in his heart constantly. Also, the center of wandering also means the place where his life and death are linked to each other. When he knows that death also brings him salvation, he also knows that the death is connected to the new life. In that sense, the center of wandering (the center of the *Tonnetz* graph) represents the wanderer's home as well as his mental "home," the goal that he finally reaches when he realizes that he can accept death as his salvation. The wanderer's journey, or Schubert's life itself, is represented by the cyclic formation between life and death, just like the triangle configuration on the graph.

Tonnetz Graph 6.5: Sonata in C minor D. 958 (1–4 movements)

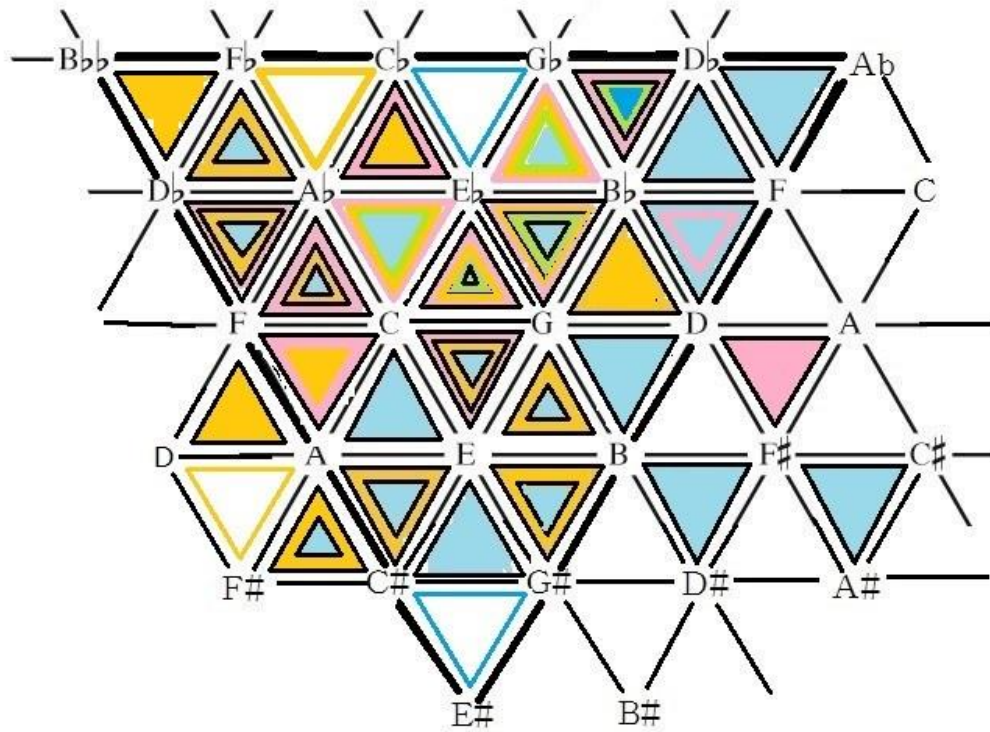

CHAPTER VII

THE “WANDERER” FANTASY, D. 760 (1822)

Schubert composed the “Wanderer” Fantasy for piano in 1822. He was inspired by his song “Der Wanderer” D. 489, which was composed in 1816, set to the poem by Georg Phillip Schmidt von Lübeck. (See page 11 for the entire poem.) The opening of each movement is comprised of different aspects coming from the song; repeated notes, ascending steps, and the dactyl (long-short-short) rhythm. The poem of the song depicts the wanderer in a despairing mood, feeling alienated and having nowhere to belong. John Bell Young writes that “the poem’s speaker—much like the protagonist of *Der Winterreise*, is a disoriented loner in search of life’s meaning. It seems that, wherever he goes, he doesn’t fit in and is condemned to wander, as happiness will continue to elude him. The concluding line, “There, where you are not, is happiness,” became something of a mantra for Schubert as much as it did for nineteenth-century romanticism. Yearning, anxiety, and wanderlust, then became the virtual locus of Schubert’s burgeoning aesthetics” (Young 2009, 74). Considering this work’s association with the song “Der Wanderer” and the fact that this piece was composed a few months after Schubert wrote his autobiographical tale “Mein Traum,” we can assume that the “Wanderer” Fantasy deeply reflects Schubert’s conception of wandering.

The four movements of this work, Allegro, Adagio, Scherzo, and Finale, are unified through their motivic and thematic interrelations. One of the most obvious elements connecting these movements is the dactylic rhythm used in the outer movements and in the quoted phrase from the song “Der Wanderer” appearing in the Adagio. The use of dactylic rhythm is not the only element that connects these

movements, but also the association with the song “Der Wanderer,” since the song also contains this rhythm. As I mentioned in the previous chapters, the dactyl rhythm is one of Schubert’s favorite motifs, used in several of his compositions, like his Impromptu D. 899–No. 3 and the Moment Musical No. 5, where it expresses the formation of primordial life and death as “wandering” (long-short-short rhythm can be interpreted as a wanderer walking heavily.) The formal structure of the Fantasy also reinforces the close bond between the movements. Performed continuously without any stop between the movements, the entire work’s structure is much the same as a sonata form (where the opening Allegro functions as the exposition and the following Adagio acts as the development). William Kinderman says that “this structural plan of interconnected movements broke new ground, and provided an important model for the new genre of the symphonic poem as cultivated by Franz Liszt in the 1850s, and many other composers in the last decades of the nineteenth century” (Kinderman 1997, 166).

The work’s cyclic organization is another, and probably the most important, element that unifies the movements. Schubert’s use of the cyclical form, seen in his thematic and motivic transformations, shows the work’s continuous returning formation. Charles Fisk writes that “this fantasy is in its own way a returning cycle...the fantasy is clearly based on the third stanza of his setting of “Der Wanderer”, which provides not only the theme for the variations of the slow movement but also the leading motives for all four movements” (Fisk 2001, 7). Also, Young writes that “the “Wanderer” fantasy is a cyclical form, in that its abundance of melodies, set forth from the outset, are constantly recycled, making themselves known in every moment” (Young 2009, 71). Schubert’s use of cyclic structure in the Fantasy evokes the image of a wanderer who continually longs

to return home.

The protagonist of the original lied “Der Wanderer” expresses his alienation with the words: “Oh, land, where are you?” The text of the song portrays a wanderer who cannot find his home and recognizes himself as a “Fremd.” His despair seems to continue infinitely. But in contrast, the “Wanderer” fantasy, although the piece is based on the song, seems to portray an aspect of the wanderer’s view of life which is different from the one in the original song. The use of the cyclical form and recurrences of themes in the Fantasy seem to represent a new perspective that the wanderer holds toward his life. In the Fantasy, the wanderer now understands that he has a way to go home, at least in his dream or illusion. His homecoming may occur only for a brief moment in his dreams, but those moments, in which he dreams of returning to his home or recalls his happy old memories of the past time when he had his home, give the wanderer hope and transient happiness.

Fisk also claims that the wanderer’s journey portrayed in the Fantasy is different from the one in *Winterreise*. He describes *Winterreise*’s protagonist as follows;

“from his opening lines, the winter wanderer proclaims himself an outsider: “Fremd bin ich eingezogen, Fremd zieh ich wieder aus” (A stranger I came, a stranger I depart). He has no home with which he feels identified, and accordingly, his journey has neither origin nor goal. It begins as he turns away from the town that might have become such a home, had he succeeded there in love. But his opening avowal of his alienation suggests the inevitability of that love’s failure, the impossibility of his desire’s fulfillment, and hence the impossibility of such a home for him. As he moves on, his immersion in one frozen, barren scene after another only deepens his isolation, so that he gradually becomes alienated even from himself, losing every memory or aspiration through which he might ever have forged or retained a sense of his own

identity.” (Fisk 2001, 5)

Even though the “Wanderer” fantasy appears to have been composed some years before *Winterreise*, the wanderer’s journey in the Fantasy stands as a kind of solution or response to the protagonist of *Winterreise* who feels only despair. Fisk writes that Schubert’s “use of the very kinds of cyclic procedures that are not incorporated in the song cycle enacts a reclamation. *Winterreise* is a cycle without a center, spinning slowly out into a frozen wasteland.” But, in many of Schubert’s instrumental pieces in cyclical form (including the Fantasy), “their beginnings often suggest searching or wandering, but ultimately these compositions fulfill their quest and restore to their wanderer a sense of self-possession and belonging” (Fisk 2001, 6). By applying such a cyclic structure, the “Wanderer” fantasy not only gives the wanderer hope for homecoming, but also depicts the wanderer’s new stance toward his life—in other words, the Fantasy provides the wanderer the transcendental notion of living in a circularity between life and death. In the Fantasy, the cycle holds its center all the time, like the wanderer picturing his home in his heart at all times. Around this center, the cycle between life and death continues forever, and the wanderer eternally lives in this circularity.

The “Wanderer” Fantasy D. 760, First Movement (Allegro)

The fantasy begins with an aggressive fortissimo C-major theme. The opening three-measure motive in dactyl rhythm appears repeatedly throughout the piece, unifying the entire work. After the first V-I cadence on the tonic at measure 6, the dactyl rhythm still continues in different keys (through the temporary modulations to G major, F major and A minor). The opening fortissimo suddenly turns to piano at measure 14, but it is

followed by a convulsive crescendo leading to a cadence in fortissimo on an E-major triad. The tremolo-like figure in the right hand and the left hand's chromatic ascending scale enhance the effect of the crescendo and dramatizes this cadence. The opening three-measure motive comes back at measure 18, but this time in a modified and expanded version. The second theme arrives at measure 47 in E major, although the music implies an arrival on G major a few measures before. The E major of the second theme does not stay in its key very long, and suddenly modulates back into C major at measure 67. The return of C major and the opening material is dramatized by the tremolo in both hands (mm. 67–69). Fisk writes that the instability of the first movement even starts from this opening section; he says that the A-minor semi-cadence at measure 17 and the E-major second theme are two “disturbances” that create dynamic and textural discontinuities in the opening section. Within the C-major music, these two disturbances emphasize the E-major harmony (as dominant and as tonic) and they are both followed by the return of C major music (Fisk 2001, 65).

The appearance of E major in the first section also anticipates the C# minor of the song “Der Wanderer”, which appears at the beginning of the Adagio in the Fantasy as the principal theme of the entire work. Fisk tells us that E major is harmonically more close to C# minor than to C major, so the use of E major in the opening section functions as a “foretoken” of the emergence of the original song's C# minor that emerges in the Adagio (Fisk 2001, 65–66).

The return of the opening music after measure 67 is followed by an A-minor episode at m. 83. This intensive A-minor episode suddenly evaporates at measure 108, with the appearance of a dominant seventh of Eb major, which leads smoothly to a third

(closing) theme starting in Eb major (m. 112). This new section contains frequent modulations to different keys—the appearance of Db major at measure 130 again anticipates the song’s C# minor. The Eb major appears as an evasion of the intensity of the previous music, and the Db fanfare-like phrase comes at measure 132. The arrival to Db major is the beginning of a long and majestic modulation process back to the dominant of C major. But Fisk claims that the arrival of Db major and the use of the pitch Db as a Neapolitan of C in the later section are the foretaste of the arrival of the song’s C# minor in the second movement.

The arrival in G major at measure 143 implies its resolution to C minor (or C major), but instead of having a resolution, it proceeds to the long transition preparing for the arrival of the C#-minor theme of the Adagio. Fisk describes the last section of the first movement as follows; “in the subsequent progression the recent memory of the seemingly festive Db-major music, which was somewhat given to bravado, has surrendered its place to melancholically brooding music that moves into C# minor, as if reflecting a protagonist who generates great energy and charisma, but who also feels a consuming inner despair” (Fisk 2001, 66).

Graph 7.1 and the *Tonnetz* graph on pages 169–170 describe the harmonic transformation of the opening movement. On the *Tonnetz* graph, the brown arrow shows the approximate route of the harmonic transformations in this movement. Starting on the C major harmony, the arrow goes through the lower chords on the graph and then moves to the upper area, and finally comes back to the G major which is near the center. The harmonic route starting on the center and moving around it looks like the wanderer who leaves his home and trudges around the different lands. Arrows 1 and 2 show the E major

and Db major which are anticipating the arrival of C# minor of the second movement. These chords' closeness to the C# minor is obvious on the graph—the E major harmony and C# minor is linked by the Relative-transformation (arrow 1). Also, treating the Db major chord enharmonically as C# major (arrow (2)), the chord is in a parallel relation to the C# minor (arrow 2). These two harmonies act as the mediators to connect the first movement's C major tonality to the second movement (containing the “Wanderer” theme) in C# minor.

Graph 7.1: The “Wanderer” Fantasy D. 760, first movement, Harmonic Transformation

F
S
3rd theme (C)

m.1 8 13 17 18 29 47 57 64 66 67 76 83 92 94 112 121 122 129 130 134 136 143

CM FM EM CM EM Em CM Am Am EbM AbM DbM Bbm GbM GM (Cm) (G#M)
 GM Am GM (F#m-EM) GM (Dm) (BbM) Cm Fm

Tonnetz Graph 7.1: The “Wanderer” Fantasy, first movement (D. 760-1)

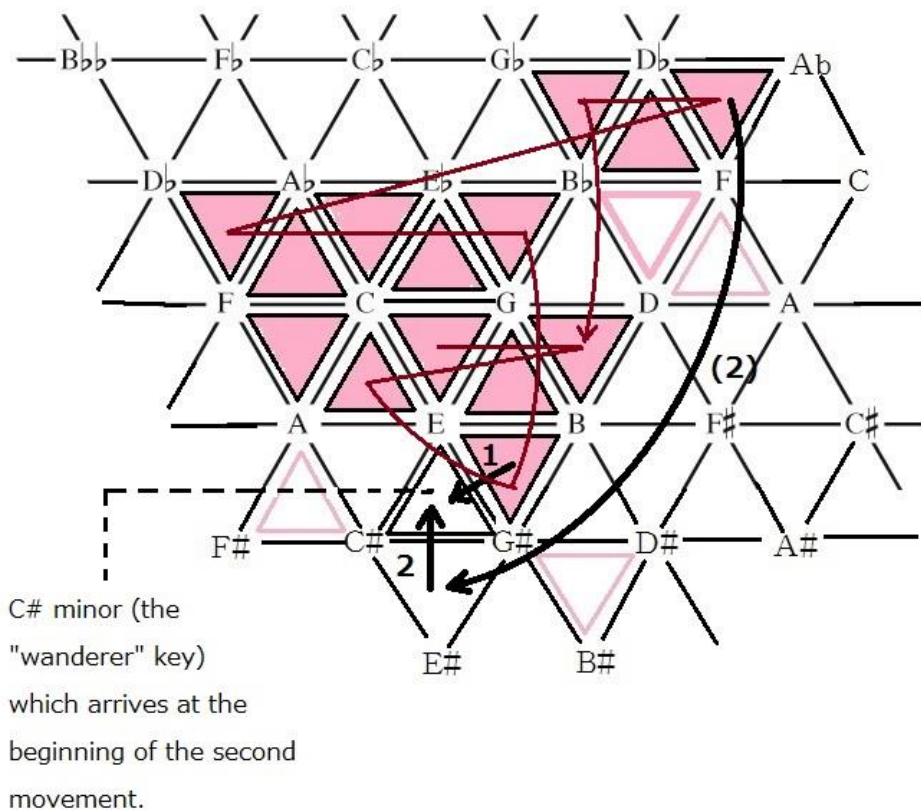

The “Wanderer” Fantasy D. 760, Second Movement (Adagio)

The C#-minor theme of the Adagio is in a despairing mood, reflecting the wanderer’s inner sentiments in the original song. The appearance of this C#-minor theme in pianissimo is a substantial contrast to the first movement’s disturbing and explosive character. There is an important and central conflict between the C major of the opening movement and the Adagio’s C# minor. As I indicated in chapter 3 (on p. 43), Charles Fisk calls Schubert’s use of C# minor the “wanderer’s key,” with respect to the alternate appearances of the C major and C# minor sections in the A-major sonata D. 959. In that

sonata, conflicting C major and C# minor, representing the wanderer's dream and ensuing nightmare, alternate with one another and are finally integrated with each other in the finale. The same kind of contrast happens in the "Wanderer" fantasy. Even the transition between the end of the first movement and beginning of the second emphasizes a sense of contrast and surprise: after m. 143 in the first movement, we seem to be in a dominant prolongation that will eventually lead us back to C major, but a sudden E# diminished seventh chord in m. 167 causes the music to veer away into a new tonal course, which ultimately leads to the C# minor of the Adagio.

The principal theme of the Adagio, which is reminiscent of the song "Der Wanderer's" third stanza, is followed by a set of variations on this theme. Fisk writes that these variations in different major and minor keys "find within this initially C#-minor territory the most extreme possible contrasts of gesture and mood. They suggest an exploration in imagination of the relationship between terror in a lonely confrontation with nature and the possibility of revelatory consolation in its midst. Unlike the stormy interlude in the opening Allegro, these storms actually subside like storms lived through" (Fisk 2001, 66–67). But Schubert provides a sense of unity through these variations by continually using the opening dactyl rhythm that unifies the entire work. Young states that these variations, which are played without any pause and continually use the same dactyl motive, "bear a structural resemblance to Chopin's dreamy *Berceuse*" (Young 2009, 82).

There is a mutual relation between the song's text and the musical responses to it in the Adagio. The Adagio's principal theme emphasizes the C# minor as its own key. The theme also highlights the pitch C# as its melodic high-point (on the third beat of measure

195; see score on page 174, Example 7.3). In the original song, the corresponding melody of the third stanza reaches to C# in measure 29, emphasizing the word “Fremdling.” (the score is attached on page 173, Example 7.2.) Reflecting the song’s highlighted word “Fremdling,” the C# minor, or the pitch C#, in the fantasy portrays the image of the wanderer feeling alienation. In the song, most of the remaining sections that follow are in E major, but “the opening three stanzas have given their weight to C# minor, and this key never quite relinquishes its tonal hold over the song” (Fisk 2001, 68). The highlighted C# minor, and the pitch C#, in the original song is inherited by the fantasy—it represents the wanderer’s identification of himself as the stranger and gives rise to the despairing mood of the Adagio.

Fisk also explains how the conflict of C# minor and E major in the fantasy is derived from the original song. In the song, the second stanza from measure 16 begins in E major, and this music is set to the words “Ich wandle still, bin wenig froh (I wander quietly, am scarcely happy), “bringing its protagonist into focus in quiet reflection” (Fisk 2001, 69). This phrase is followed by “und immer fragt der Seufzer: wo, immer wo? (and always asks my sigh: where, always where?)” in C# minor, “as if to capture the desolation that he experiences in that quietness” (Fisk 2001, 69). (The score of these two phrases is attached on p. 173, Example 7.1.) These E-major and C#-minor phrases reappear in the last section with the same words and music, leading to the conclusion “dort wo du nicht bist, dort ist das Glück (there, where you are not, there is happiness)” in E major, “almost demand[ing] musical inconclusiveness” (Fisk 2001, 69). Essentially, the two keys (according to Fisk and John Bell Young) represent the hope (or hallucination) of finding home (E major), and the reality that the wanderer must remain a stranger (C#

minor). In the Fantasy, the juxtaposition of E major and C# minor can be interpreted the same way.

Example 7.1: “Der Wanderer”, D. 489, mm. 14–22

Musical score for Example 7.1, measures 14–22. The score is in E major (three sharps) and 3/4 time. It features a vocal line and a piano accompaniment. The lyrics are: "Meer. Ich wandle still, bin we-nig froh, und im-mer fragt der Seuf-zer: wo? im-mer wo? Die". The piano part includes dynamic markings *fp*, *pp*, and *ppp*. The vocal line has a fermata over the word "Meer" and a slur over the phrase "und im-mer fragt der Seuf-zer: wo? im-mer wo?".

Example 7.2: “Der Wanderer”, D. 489, mm. 23–30

Musical score for Example 7.2, measures 23–30. The score is in E major (three sharps) and 3/4 time. It features a vocal line and a piano accompaniment. The lyrics are: "Son-ne dünkt mich hier so kalt, die Blü-te welk, das Le-ben alt, und was sie re-den, lee-rer Schall, ich bin ein Fremd-ling ü-ber-all." The piano part includes a dynamic marking *pp*. The vocal line has a slur over the phrase "Son-ne dünkt mich hier so kalt, die Blü-te welk, das Le-ben alt, und" and another slur over "was sie re-den, lee-rer Schall, ich bin ein Fremd-ling ü-ber-all".

Example 7.3: The “Wanderer” Fantasy, D. 760, Adagio, mm. 189–197

The image shows two systems of musical notation for the 'Wanderer' Fantasy, Adagio, measures 189-197. The first system starts at measure 189 and the second at measure 194. The music is in G major (one sharp) and 4/4 time. The dynamics are marked as piano (pp). The notation includes slurs, accents, and fingering (5, 7). The piece is in a slow, adagio tempo.

The harmonic transformation of this piece is described on graph 7.2 and the *Tonnetz* graph on the next page. The graph describes the closeness of the E major, the “key of hallucination of finding the wanderer’s home-land” (Fisk 2001, 69), to the second movement’s principal key C# minor, the “wanderer” key (arrow 1). In addition, the other major-keys, A major and C# major harmonies, also appear temporally in the music, functioning in a contrasting way to the C# minor. Having C# minor at the center, these keys are placed next to its sides. While the C# minor represents the wanderer’s dismay, his dreams or illusions of homecoming are represented by the harmonies surrounding this chord. Comparing this graph with the graph of the first movement, we notice that the chords’ positions are moved to the lower area of the *Tonnetz*, as the music moves away from the work’s opening key C major. We can understand this move as associated with the wanderer’s sense of being far from home.

Graph 7.2: The “Wanderer” Fantasy D. 760, second movement, Harmonic Transformation

Theme	1st Var.		2nd Var.		3rd Var.			4th Var.	5th	6th Var.		7th Var.		
m.189	196	199	202	206	207	209	215	219	223	227	230	(235)	236	242

C#m EM C#m EM C#m AM C#m C#M C#m EM C#M C#m EM (F#m) C#M EM

Tonnetz Graph 7.2: The “Wanderer” Fantasy, second movement (D. 760-2)

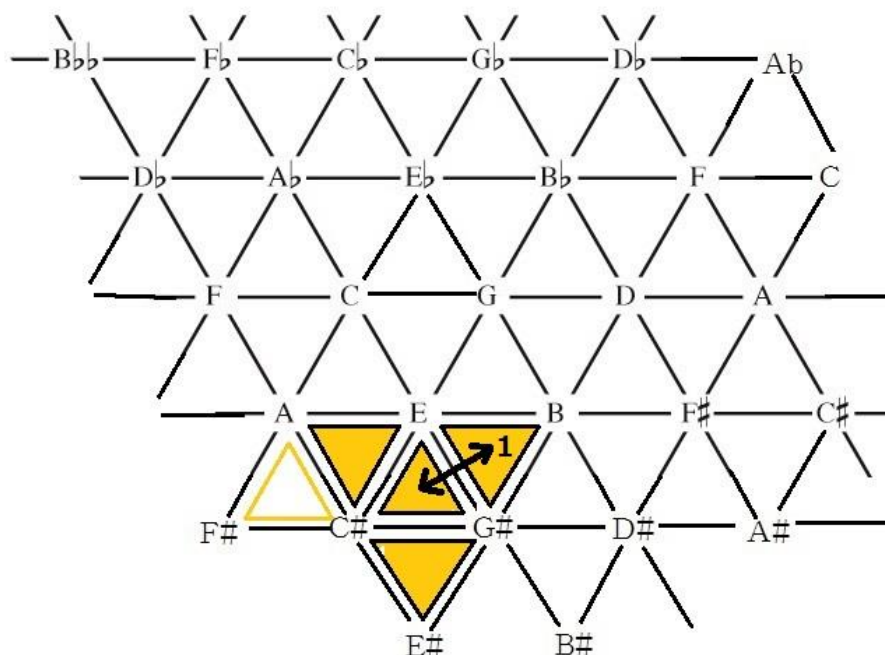

The “Wanderer” Fantasy D. 760, Third Movement (Scherzo)

Schubert marks the third movement’s tempo Presto, but it actually functions as a Scherzo. This movement starts in Ab major. The irregular and unbalanced lengths of the opening phrases, eight-measure and six-measure long phrases, enhance the capricious mood of the piece, and contrasts with the strict four-measure period of the Adagio’s

opening. Even though the long-short-short dactyl rhythm, which was used in the preceding movements, does not appear here, Young states that the dotted rhythm through measure 247–248 is the modified version of the dactyl, “now transformed and rhythmically altered into an electrifying dotted-note long-short-long dotted-note pattern” (Young 2009, 84).

Starting from measure 303, diminished seventh chord arpeggios are played both ascending and descending. The pitch Db is emphasized here, as “the enharmonic equivalent of C#, and thus a subtle mnemonic reference to the *Fremdling* key of the Adagio” (Young 2009, 84). What follows it is the second subject in Cb major at measure 323. This second subject has a peaceful and elastic melody. Young says that “the key is an interesting choice, in that it is the enharmonic equivalent of B-major, which is the dominant of E major—the very key in which the Adagio’s *Fremdling* antidote, so redolent with hope, is written” (Young 2009, 84–85). The Db-major theme at measure 431 recalls the “*Anschlag* motive (from m. 112) from the Allegro con fuoco, now recycled and deftly harmonized below with prolonged tonic and dominant chords” (Young 2009, 85). The Scherzo’s main phrase comes back at measure 521, but the music suddenly transforms to A minor in measure 535. Even though the music maintains the same rhythm, the massive chords and explosive crescendo after measure 545 remind us of the opening movement. The right-hand’s tremolo figure and the chromatic ascending scale in the left hand through measures 545–548 recall a similar motive found in the first movement (mm. 14–15). While those motives and the aggressiveness of the first movement come back here, Young says that “the overriding purpose of this codetta is not to consolidate old themes or motives, nor to introduce anything new; rather, its function

is transitional, a means to move seamlessly from the Scherzo’s principal key, A-flat, to the finale’s C-major” (Young 2009, 86). This movement ends with the accented G-major chord, the dominant of C major, anticipating the full arrival to C major at the beginning of the Finale. The harmonic transformation of this movement is illustrated by Graph 7.3 below and the *Tonnetz* on the next page. The arrows on the *Tonnetz* describe the transformations between the piece’s principal keys, between the first theme and the second theme (arrow 1) and shift from the end of the second theme to the third theme (arrow 2). These two transformations are almost equally distanced from the main key Ab major, just like the wanderer who strolls around, keeping a certain distance from his home. Arrow 3 represents the transformation between the final AbM and the arrival of the C major which comes at the beginning of the final movement. Also, comparing it with the graph of the second movement, we notice that the placements of the chords on the graph have moved to the upper area of the graph, in contrast to the key areas of the Adagio which were mostly at the bottom.

Graph 7.3: The “Wanderer” Fantasy D. 760, third movement, Harmonic Transformation

F **S** **(F) 3rd Theme** **(F) Trans.**

m.245 273 275 301 303 317 339 343 347 375 431 458 459 477 489 513 521 535 582

AbM AbM DbM Ebm Fm Abm DbM Bbm DbM AbM (CM)
 EbM EbM CbM AbM Fm GbM BbbM (Am-Bbm-Bm-Cm)

Tonnetz Graph 7.3: The “Wanderer” Fantasy, third movement (D. 760-3)

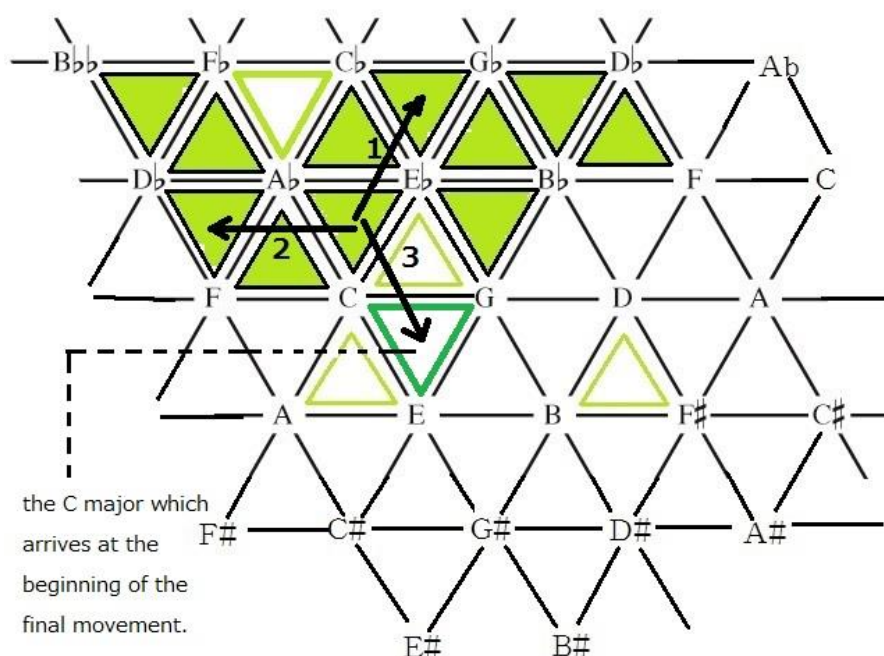

The “Wanderer” Fantasy D. 760, Fourth Movement (Finale; Allegro)

The final movement starts with C-octaves in the left hand in dactyl rhythm. Recapturing its former prominence, the dactyl rhythm predominantly appears throughout the Finale. Young calls the continual dactyl rhythm of this movement a “dactylic tornado.” “As a whirlwind of arpeggios flies by in the right hand, the left throws down the dactyl repeatedly as if it were Jupiter hurling thunderbolts. Roles reverse when the right hand assumes the dactyl and the left inherits a torrent of broken chords” (Young 2009, 86). All the characteristic materials first introduced in the opening movement, such as the dactyl rhythm, wide-ranging chords, chromatic ascending scales, ascending and descending arpeggios, and tremolos, come back in this movement. These materials dramatize this last movement, and present a scene of kaleidoscopic changes.

Even though harmonic transformation frequently occurs, the C-major music majestically breaks through throughout the movement. While the original song “Der Wanderer” concluded in an ambiguous E-major, representing doubt about whether the wanderer would ever find home, this Fantasy’s conclusion is in a bright and triumphant C major. Fisk claims that this C-major conclusion is the utopian overcoming of the alienation of the wanderer. He says that “in its unambiguous, exuberant C-major conclusion, the fantasy, in contrast to the song, also resolves its central tonal conflict, as if in a utopian overcoming of the alienated state of the song’s protagonist” (Fisk 2001, 71).

The dominance of C major in the Finale is shown clearly on Graph 7.4 and the *Tonnetz* on the next page (the movement opens in C major and returns to C major at the end, as the arrow indicates the course of the transformation.) By concluding in C major, a move which was not implemented in the original song, Schubert now gives his wanderer a new direction to proceed with his life. As we explore the place C major holds on the *Tonnetz*, we shall find that this direction could very well represent a homecoming. Also, through the graphs of these four movements of this work, we have seen the route of the chord transformations which first starts on the center of the triangle configuration (in the first movement) then moves to the lower area (second movement) and goes back to the upper area (third movement) then finally comes back to its starting point, the center of the configuration (final movement). This circulated formation on the graph describes the wanderer’s whole journey leaving his home and strolling around the different lands and coming back to the original place at the end.

Graph 7.4: The “Wanderer” Fantasy D. 760, fourth movement, Harmonic Transformation

m.598 612 624 636 641 644 648 659
 CM (GM CM Dm Em Bm GM Em) CM

Tonnetz Graph 7.4: The “Wanderer” Fantasy, fourth movement (D. 760-4)

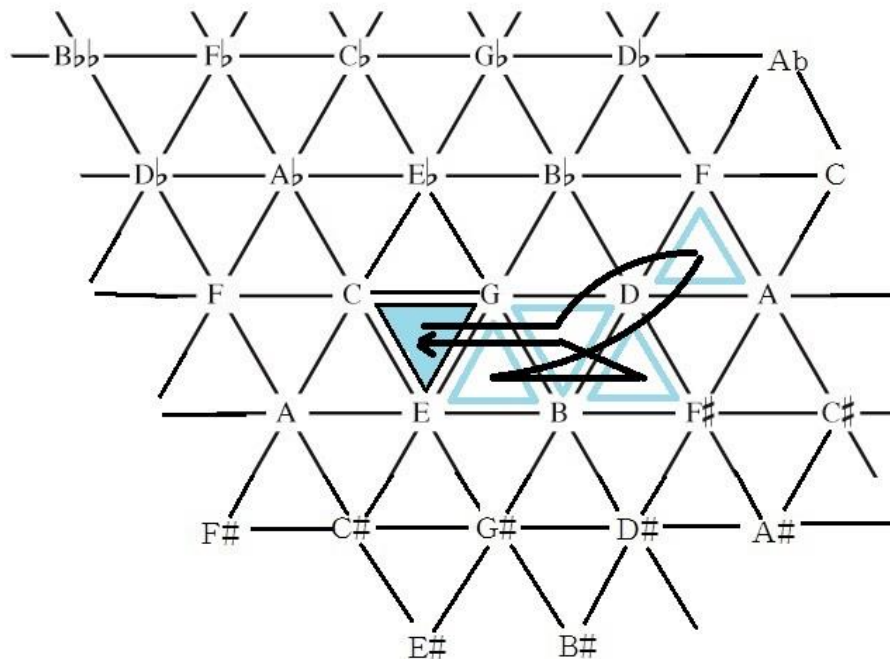

The “Wanderer” Fantasy recalls and develops the ideas of its original song and that song’s story through a variety of elements; the quotation of the C#-minor theme, the long-short-short dactyl rhythm, the repeated notes, the ascending chromatic and diatonic scales—all are derived from the original song. In the Fantasy, these elements express the image of the wanderer even more dramatically than in the song. Also, the contrasting keys, such as C major and C# minor, or C# minor and E major, depict the wanderer’s contrasting inner sentiments, between dream and reality, or pain and love. Fisk writes as follows;

In the absence of words, a tonal contrast of this moderate degree is unlikely to suggest such disparity (between enraptured illusions of belonging and a desolate awareness of actual isolation). But the contrast on which Schubert bases the tonal structure of the “Wanderer” Fantasy, especially as the composition dramatizes it, easily suggests a contrast, even a conflict or a contradiction, between disparate and even incompatible experiences or ways of being. One could relate this tonal and gestural conflict between the C-major music and the C#-minor music in the fantasy to any number of stereotypes of conflict in different spheres of life. Within the realms of art, it might mirror a conflict between the epic and the lyric poet, or even between the instrumentalist and the singer in music itself. The derivation of the fantasy’s C#-minor music from the stanza of “Der Wanderer” that introduces its *Fremdling*, however, suggests a specific range of interpretations—ones that set happy, even joyous, feelings of inclusion against desolate feelings of alienation. The contrasts within the fantasy, not only tonal but also gestural and textural, bespeak such a conflict much more powerfully than do the contrasts in the song.” (Fisk 2001, 69–71)

While there are affinities between the song “Der Wanderer” and the Fantasy based on it, the fantasy’s cyclic formation and Schubert’s choice of a C-major conclusion suggest a new kind of resolution to the wanderer’s journey. The cyclic structure, where

the music returns to the same material continuously throughout the work, represents the wanderer's way to return to his home, and also depicts the circularity of human life and death. With this circular formation, the protagonist of the song "Der Wanderer," who was in the depths of despair, now finds a way to live. The Fantasy tells us the story of the wanderer who finds a resolution at the end of his journey. Perhaps, this story represents Schubert's own life and his hopes about his life. By introducing a cyclic structure and C-major conclusion, Schubert not only provides a resolution for the protagonist of the poem, but also gives hope to the "Fremdling" himself. Schubert "the Wanderer" struggled between pain and love (as he describes in his tale "Mein Traum"), and between life and death, throughout his life. In the Fantasy, the conflicts between C major and C# minor, E major and C# minor, describe those struggles that Schubert had in his actual life. The conflict between C major and C# minor is reflected on the *Tonnetz* graph 7.5 on the next page (which includes all the prior chords and keys of the entire work)—the C major is placed at the center of the triangle configuration, which represents the wanderer's home. Although the C# minor is placed vertically next to C major, C# minor is one step away from the center, closer to the lower edge of the configuration, and it seems to represent the wanderer's alienation. (I will discuss more about the conflict between C and C# regions in chapter 8.) But the Fantasy also holds out the hope of a utopian resolution that would be Schubert's own ideal. Perhaps, Schubert was able to find his own way to return to his home, but only in his music. The *Tonnetz* graph 7.5 geometrically shows this utopian resolution. In the final movement (colored in blue), the music, after circling around it for the entire Fantasy, finally returns to the opening C major, which is placed at the center of the triangle. This formation is a geometrical representation of the wanderer's

homecoming. I suggest that the triangle configuration on the *Tonnetz* represents the wanderer’s circular journey between life and death, and the ideal life-journey back toward home that Schubert “the wanderer” drew in his heart.

Tonnetz Graph 7.5: The “Wanderer” Fantasy D. 760 (1–4 movements)

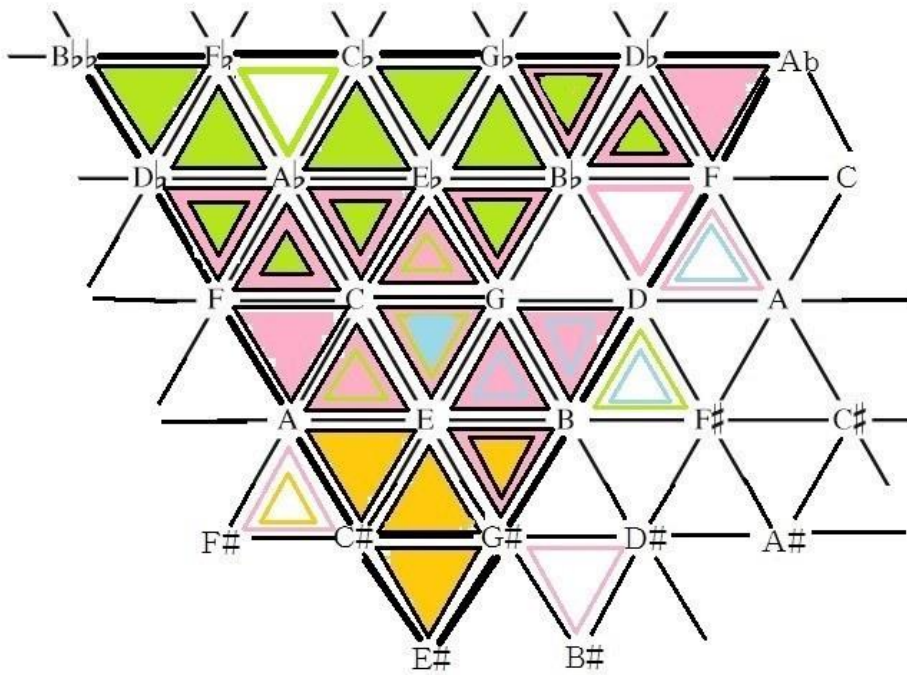

CHAPTER VIII

SCHUBERT'S "WANDERING" EXPLAINED BY THE TRIANGLE CONFIGURATIONS

Through chapters 4–7, I have presented *Tonnetz* graphs (and a few Schenkerian graphs as well) of a number of Schubert's pieces (*Impromptus* D. 899, *Moments Musical* D. 780, C-minor Sonata D. 958, and *Wanderer Fantasy* D. 760). On these *Tonnetz* graphs of four works by Schubert, we have seen, again and again, reversed-triangle configurations. What do these configurations represent? Why do similar configurations appear on the different graphs?

In chapter 2, I discussed the concept of wandering as a representation of the cyclic formation of human life and death. The circular nature of life and death coincides with Schubert's concept of wandering and the cyclic organization of his music. I believe that the triangle configurations on the *Tonnetz* graphs represent the concept of wandering, described as a "timeless circular path between life and death" (Adorno 2005, 10). Theodor Adorno describes the indispensable quality of wandering as a "landscape of death," in which "every point is equally close to the center" (Adorno 2005, 10). In that landscape, a wanderer walks around death and is equally close to it all the time. I suppose that the triangle configurations appearing on my study's *Tonnetz* graphs are geometrical representations of the concept of wandering, and as such they illustrate landscape of human life and death. In this concluding chapter, I would like to compare the four *Tonnetz* graphs that we have seen in the preceding chapters and suggest possible ways to comprehend the triangle configurations on the graphs.

Flat-chord and Sharp-chord Ranges

In order to consider the main factors of this phenomenon on the *Tonnetz* graphs, the appearance of similar reversed triangles, I would like to look into the characteristic similarities between these four graphs and corresponding musical affinities between these four works. Firstly, comparing these *Tonnetz* graphs, we notice that all of these works use the flat-chords/flat-keys more frequently than the sharp-chords/sharp-keys. (The *Tonnetz* graphs are attached on page 186 for comparison.) This fact accounts for the upper/lower sides of the reversed triangle (the upper larger part which covers the flat-chord area against the lower corner which covers some sharp-chords). For example, in the *Tonnetz* graph of the *Impromptus* D. 899, the pitch G# is the only sharp-note placed within the triangle configuration, and the E-major chord, which has the G# as one of its chord-tones, is the only sharp-chord within the configuration. (Although some other sharp-chords, such as C#-major/minor chords and F#-minor chord, are placed outside the triangle configuration.) Similarly, in the graph of *Moments Musical* D. 780, the lower corner of the triangle configuration is filled with the four sharp-chords used in its fourth movement (A-major, C#-minor, C#-major and E-major), and the upper, larger, part of the triangle is made up of the flat-chords. The same four sharp-chords are also used in the Sonata and the Fantasy, filling out their triangles' lower corner. Thus, in each graph, the proportion of flat-chords against sharp-chords constructs the reversed triangle configuration. (In the C-minor sonata and the Wanderer Fantasy, the proportions of the use of flat-chords against sharp-chords become much higher, resulting in the bigger triangle configurations on the graphs.)

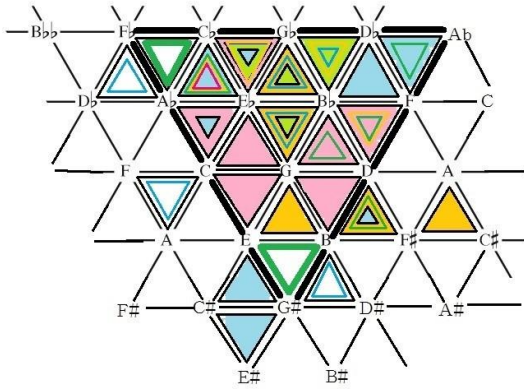

Impromptus D. 899 (1–4 movements)

Color-classification:

- 1st movement (pink)
- 2nd movement (yellow)
- 3rd movement (green)
- 4th movement (blue)

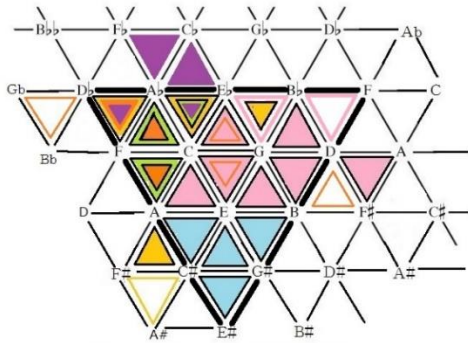

Moments Musical D. 780 (1–6 movements)

Color-classification:

- 1st movement (pink)
- 2nd movement (yellow)
- 3rd movement (green)
- 4th movement (blue)
- 5th movement (orange)
- 6th movement (purple)

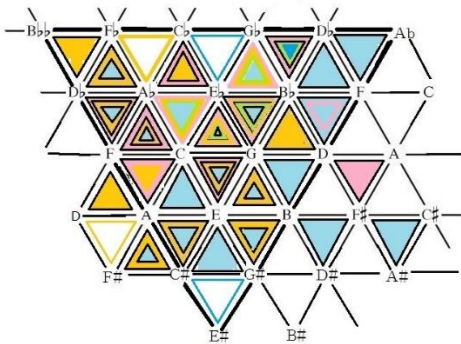

Sonata in C-minor D. 958 (1–4 movements)

Color-classification:

- 1st movement (pink)
- 2nd movement (yellow)
- 3rd movement (green)
- 4th movement (blue)

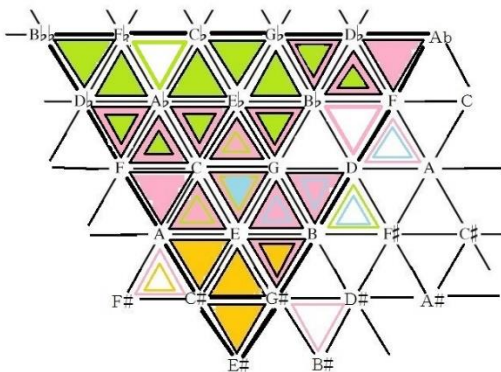

Wanderer Fantasy D. 760 (1–4 movements)

Color-classification:

- 1st movement (pink)
- 2nd movement (yellow)
- 3rd movement (green)
- 4th movement (blue)

Conflicting Keys—C major/minor Region vs C# minor/major Region

As I mentioned in chapter 3, Charles Fisk writes about the contrasting keys, C major and C# minor, used in Schubert's A-major sonata D. 959. These contrasting keys appear prominently in that sonata, representing the wanderer's dream (C major) against the dream's nightmarish opposite (C# minor). Fisk writes that "in the A-major sonata, for example, the static C-major dream sequence of the first movement's development may linger in memory, at that movement's end, as an unintegrated, quasi-independent episode. At the end of the Andantino, the C#-minor episode, the dream's nightmarish opposite, may still seem to override in importance the theme that surrounds it...even in the Scherzo, the A-major, C-major, and C#-minor passages all carry nearly equal weight. By now they all also carry specific memories that prepare for what in the finale will become, for all its lyric expansiveness, a systematic integration" (Fisk 2001, 276). In the finale of the A major sonata, the C-major and C#-minor music is united, representing the contrasting emotions of the wanderer finally being integrated, as he finds a way to be released from his agony and finds his mental home. Thus, the opposite keys C major and C# minor, or the C and C# regions, in Schubert's music can be understood to represent the wanderer's sentiments changing through his journey.

These same two contrasting key areas, C and C#, also appear in each of the four works that I examined in this dissertation. In his study of the "*Wanderer*" fantasy, Fisk discusses the way Schubert incorporates the C# minor of the original song into the C-major fantasy. He writes that "the song that now begins (the "*Wanderer*" theme in Adagio) does not so much follow the Allegro as displace it, or at least displace the

confirming conclusion for which it has prepared. In this way the C# minor of the Adagio, the wanderer's song, forcefully intrudes upon the C major of the Allegro" (Fisk 2001, 63–64). Schubert's way of incorporating C# minor into the Fantasy sets these contrasting keys against each other, describing the wanderer's conflicted emotions.

It is true that the arrival of the C#-minor Adagio is prepared by other keys that are related to C# minor. "The conflict is dramatically, even violently presented; but it is not unprepared. E major and Db major, both keys closely related to the song's C# minor, make striking appearances in the course of [the] opening movement..." (Fisk 2001, 64). Since the E-major harmony used in the first movement has a closer connection to C# minor than to C major, this harmony acts "as a foretoken of the eventual emergence of the song's C# minor" (Fisk 2001, 66). Also, Db-major, which arrives around measure 130 in the opening movement, prepares the song's C# minor that appears a few pages later. This Db major can be understood as a more positive, assured version of the move melancholy C# minor music to come. The appearances of E major and Db major in the first movement thus function as harmonies that prepare for the arrival of the song's C#-minor, and as mediators to connect the opening's C major and the contrasting C# minor of the second movement. (The *Tonnetz* Graph 8.1 on page 190 illustrates the closeness of E major and Db major used in the first movement to C# minor of the second movement.)

The Ab-major tonality of the third movement of the *Wanderer* Fantasy is still closer to C# (or enharmonically Db) major/minor than to the opening C major. But the third movement finds its way to return to the opening C major of the Finale, through the harmonic transition in the stormy interlude at the end of the movement; in measures 586 to 593, Schubert adds F# to the Ab-major chord to create the German sixth harmony. The

Ab-dominant seventh chord (of C#/Db major or minor) which was used in the preceding sections now transforms to the German sixth chord (of C major), linking the movements and the remote tonalities of C# minor and C major.

The *Impromptus* D. 899 are also a good example of the distant but mutual relation between C region and C# region that Schubert incorporates into his music. As I mentioned in Chapter 4, the fourth impromptu closely relates to Schubert's song "Der Wanderer," and its Trio's C# minor shares its tonality with the melody of "Der Wanderer" and the "Wanderer" Fantasy. As we have called C# minor the "Wanderer" key, the C# minor of the Trio introduces images of uncertainty and loneliness related to the wanderer's journey. Furthermore, the shift from Ab major to C# minor in the fourth impromptu corresponds to the contrasting images of wandering; that is, the Ab major representing the temporal arrival at his home in the wanderer's illusion, contrasting with the C# minor describing the moment when he returns to dismal reality. Also, the C# minor not only contrasts with Ab major but also with C minor of the opening movement. The opening C minor describes the wanderer's journey just beginning, as he still meanders around his home. Even though he has already recognized himself as a "Fremd" at that point, his feeling of alienation increases through his journey. The arrival at C# minor in the Trio of the last movement represents, by incorporating the same tonality that the song "Der Wanderer" uses, the wanderer's increased loneliness in his heart.

Tonnetz Graph 8.1: C major → C# minor transformation supported by E major and Db major (*Wanderer Fantasy*)

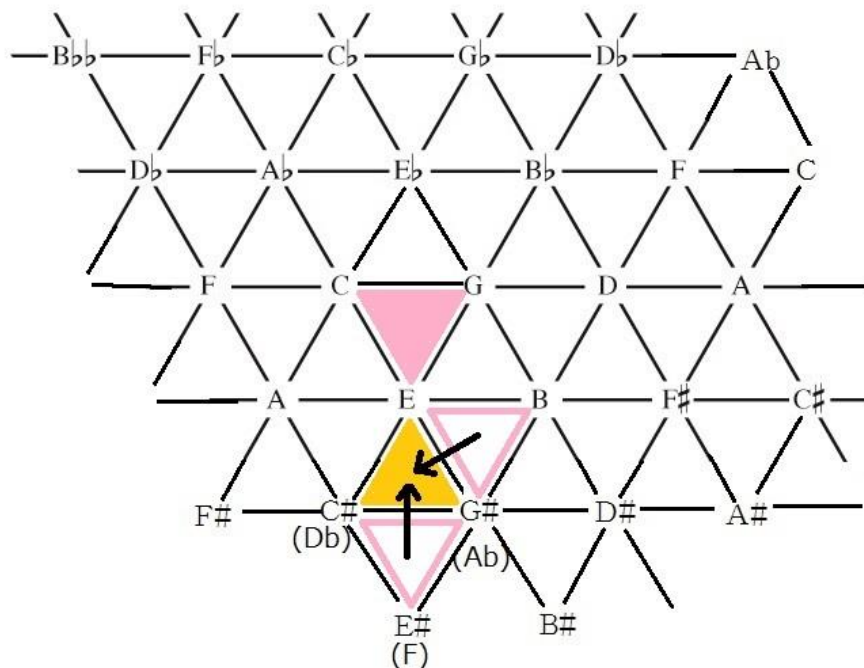

In *Moments Musical D. 780*, C# minor appears as the principal key of the fourth movement. As we have seen in the *Wanderer Fantasy*, where Db major prepares the arrival of C# minor, the Moment Musical No. 4 also incorporates Db major as the key of its B section. Even though the Db major in the fourth Moment Musical functions as a contrasting key against C# minor, rather than as the supporting key, these two key areas are in an enharmonically parallel relation (enharmonically treated Db major (= C# major) and C# minor), and that contrasting but mutual relation typifies the wanderer's emotions struggling between reality and dream, which conflict, but are mutual to each other. While the C-major music that the opening movement brings at the beginning of the work seems

to represent the wanderer's happy memories in his illusion, this C#-minor music of the fourth movement makes us strongly feel the wanderer's despair. As I indicated in chapter 5, these two movements, Moments Musical No. 1 and No. 4, share similar musical textures, where both themes are in broken-chord figuration. Even though similar textures are used, these two movements clearly contrast in their tonalities, portraying the wanderer's deepening dismal sentiment.

The C-minor Sonata D. 958 also shows the contrasting tonalities of C major versus C# minor in the fourth movement. In the first section of this movement, Schubert again uses Db-major and the pitch Db to mediate the transformation from the opening C minor to the B-section's C# minor, just as he did in his *Wanderer* Fantasy. As I mentioned in chapter 6, the tarantella of the fourth movement represents death as salvation. Its association with the *Winterreise* songs in the preceding movements seems to describe the wanderer's despair about his death, but in the final movement Schubert expresses a different perspective toward death—death as relief and salvation. Perhaps, the C and C# regions appearing in the final movement of the sonata represent the struggles between the hopeless protagonist of the *Winterreise* and Schubert's conception of death as something to hope for.

The contrasting tonal regions, C and C#, are used in all four of these works by Schubert, illustrating the wanderer's conflicted emotions. Diagram 4 on page 193 describes the use of C-major/minor and C#-major/minor regions in each work. C#-minor, the principal key of the song "Der Wanderer" and of the quoted phrase from the song in the *Wanderer* Fantasy, represents the wanderer's despairing emotion. Considering the fact that Schubert chose C# minor as the principal key of the song "Der Wanderer" and placed

the pitch C# on the word “Fremdling” at the melodic highpoint in measure 29 of the song, we can interpret it without any doubt as the “Wanderer” key. Fisk writes that “the tonal and gestural conflict (between the C-major music and the C#-minor music in the Fantasy) suggests a specific range of interpretations—ones that set happy, even joyous, feelings of inclusion against desolate feelings of alienation.” In other words, C# minor, especially in the *Wanderer* Fantasy, functions as the symbolic tonal area describing the wanderer’s alienation. The relationship between these contrasting tonal regions C and C# can be perceived on the four *Tonnetz* graphs. Within the triangle configurations on the graphs (see graphs on page 186), the C# major/minor is always placed at the lower corner, against the C major/minor which is located at or near the center of the configuration. As we regard these triangle configurations as the harmonic transformations representing the wanderer’s journey, the C# major/minor located at the lower corner of the triangles seems to express the wanderer’s alienation. (In the graph of the *Impromptus*, C#-major/minor chords are outside the triangle configuration, also representing the alienation of the wanderer.) These C# major/minor keys generate most of the few sharp-chords used in each work, contrasting against larger numbers of flat chords. Considering this fact, these sharp-chords, including the C# major/minor, are remote from the most of the flat-keys in the works and the opening C major/minor keys, intelligibly representing the wanderer’s feeling of alienation, as the *Tonnetz* graphs geometrically show. Fisk writes that some of Schubert’s later instrumental pieces are possibly understood through the story they bring—“a story of a diffused or divided self that seeks or finds integration” (Fisk 2001, 71)—like the story of the wanderer that Schubert portrays in his allegorical story. I suggest that understanding the contrasting C and C# tonal regions as the

conflicting emotions of the wanderer is one way to grasp such a wandering story behind Schubert's music.

Diagram 4: C versus C# tonal regions in each work

Impromptus D. 899



Moment Musical D. 780

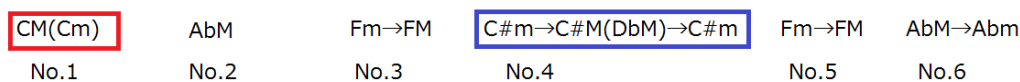

C-minor Sonata D. 958

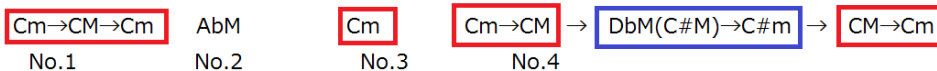

Wanderer Fantasy D. 760

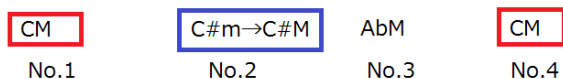

C major/minor as a Center of “Wandering”

If we regard the C# major/minor as “wanderer” keys, then how should we understand the C major/minor, which contrast with the C# region? What do C major/minor represent? As I suggested before, the C-major tonality expresses the wanderer’s dream or happy memories, against C# minor’s image of the wanderer’s despair. At the same time, we can regard the C major (and C minor) as the center of

“wandering.” The significant feature which is common to these four works (*Impromptus*, *Moments Musical*, Cm sonata and *Fantasy*) is that these are all C-major/C-minor works (the opening movement of each work starts in either C major or C minor.) So, we can regard the keys C major/minor and its tonic C as the tonal center of each of these works. Also, considering the quality of pitch C in general, it seems to have a quality of the “center”—middle C is placed on the center of the piano keyboard and also the center of the piano’s grand staff. It is regarded as the center of all other pitches as well as the fundamental pitch of music itself. Schubert chose this key and pitch for the tonic of these four works, and thus I presume that the pitch C (or C major/C minor) in these four works represents the center of “wandering,” the home to which the wanderer seeks to return. The *Tonnetz* graphs also geometrically show the C major/minor as “center”—they are placed at or near the center of the triangle configurations on the second, third and fourth graphs (the *Tonnetz* for the *Impromptus* is the only exception).

In Chapter 2, I discussed the landscape of death, in which every point is equally close to the center. The “center” of that landscape represents that place where life and death intersect in the timeless cycle. Life and death conflict but are mutual to each other, existing at the same place as the center of the wanderer’s circling motion. I assume that the tonal C region in these four Schubert pieces represents the center of the wanderer’s cycle: where life and death conflict with but intermingle with each other to return to his origin.

Wanderer’s Journey Represented by the Triangle Configurations

Comparing the four *Tonnetz* graphs, we also notice that the chords/keys used in the

first movement (first piece) of the first two works are located on or near the center of the triangle-shape on the graphs, while the final movements mainly involve chords/keys placed near the edge of the triangle instead. The C-minor Sonata and the “Wanderer” Fantasy, on the other hand, return to the C major or minor regions at the end of the work. As I indicated in chapter 4, the first kind of formation, chords shifting from the central area to the edge of the configuration, seems to represent the wanderer’s path through his journey, where the “wanderer” leaves his home (center) and meanders into the distant lands (edges). For example, in the graph of the *Impromptus* D. 899, the chords used in the first movement are located near the center of the triangle, representing the wanderer’s journey at its beginning, where he still meanders around his home. Also, as I mentioned in chapter 4, the pitch G, which is located at the very center of the triangle configuration, seems to represent the wanderer’s home or the place where he begins his journey, considering the fact that Schubert chose this pitch as the opening pitch of the work. On the other hand, in the *Tonnetz* graph we see that the final movement of the *Impromptus* involves keys and chords located near the edge of the configuration (some of them are even placed outside the triangle configuration). These chords placed remotely from the central area of the configuration seem to represent the wanderer’s path reaching distant lands, but keeping a certain distance from his home. The *Tonnetz* graph of the *Moments Musical* D. 780 also shows a similar formation, chords shifting from the center to the edges of the configuration. Looking through the distributions of the chords on the graph, we notice that most of the keys/chords involved in the first movement are located at or near the center of the triangle configuration. But the keys used in the final movement are placed near the edge or outside the triangle configuration.

Regarding this characteristic (the chords shifting from center to edges), an obvious exception among these four works is the *Wanderer Fantasy D. 760*. The *Tonnetz* graph of this work shows that the chords/keys used in the first movement are placed on/near the center of the configuration, and then the chords start to travel out a little from the center near the edge in the second and third movements. However, in the final movement, the music returns back to the opening C-major, which is placed in the very center of the configuration. It seems that this shift of chordal areas (center→edge→center) represents the wanderer's homecoming at the end of his life journey, or at least implies the wanderer's hope for homecoming. As I discussed in chapter 7, the C-major conclusion that Schubert gives as a resolution to the tonal conflict between C and C# regions through the work represents a utopian overcoming for the alienated protagonist of the original song. The return back to the center of the *Tonnetz* graph seems to geometrically describe the homecoming in reality (or in dream) that Schubert portrays in his music.

Among the four works I analyzed, the C-minor sonata is a second example that shows the tonal formation returning back to its opening key, C minor, at the end of the work. The use of the C-major/minor tonality in this work is more frequent than in the other three works that I analyzed. In the C-minor sonata, the C-major/minor tonality is used throughout the work, not only as the work's opening and closing keys, but also as the principal key of the third movement and as a key temporarily used in the second movement. Also, while the *Wanderer* fantasy returns to the opening key only at the end of the final movement, the music of the sonata returns to its opening key at the end of each movement. (Diagram 5 on the next page describes the returns of the opening key in these two works.) As the diagram shows, in the sonata, the opening C minor comes back

several times throughout the work. The repeated returns of the opening C minor in the sonata are just like the repeated exiles and homecomings of the protagonist Schubert portrays in his allegorical tale “My Dream”—each return represents the wanderer’s homecoming or his hope to return to home.

Diagram 5: Returns of the opening key in C-minor sonata and *Wanderer* fantasy

C-minor Sonata D. 958

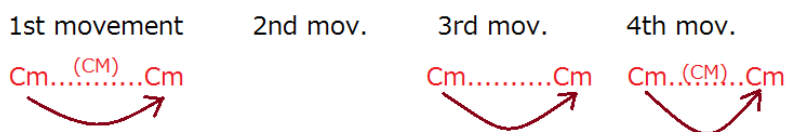

Wanderer Fantasy D. 780

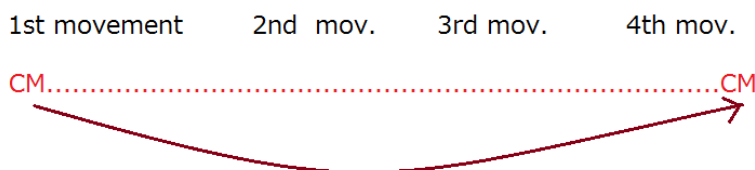

Thus, I suggest that the tonal and harmonic course that each work presents on its *Tonnetz* graph describes the wanderer’s track. The graphs of *Impromptus* and *Moments Musical* show the wanderer’s journey leaving his home and meandering out to distant lands by shifting chordal areas (center→edges). The chordal area shifting back to the center on the graphs of the Sonata and Fantasy seem to represent the wanderer’s homecomings (or, possibly, his imaginary homecoming). As I discussed in chapters 6 and 7, I assume that these two works portray different underlying stories of the wanderer. In

the Fantasy, Schubert depicts the wanderer who finally reaches a home that he can rely on. In the Sonata, the protagonist who is initially afraid of death finally accepts his death as salvation. Even though the wanderer's stories portrayed in the Fantasy and the Sonata differ, I presume that both stories represent Schubert's ideal. The resolutions of the wanderer in these two works correspond with the conclusion that Schubert himself draws in his allegorical tale "My Dream." In the tale, the protagonist who wanders for many years repeats his exiles and homecomings, struggling between love and pain. In the final scene, the protagonist enters the circle around the maiden's gravestone, and his soul revives at that moment. This is a description of death as salvation and rebirth, and with that new soul, he finally returns to his father's home and reaffirms his love. It seems to me that the Fantasy and the Sonata reflect Schubert's own hopes regarding life and death that he expresses in his allegorical tale.

Schubert's "Wandering"

In the preceding chapters, I have discussed Schubert's musical descriptions of wandering and the wanderer's inner sentiments—Schubert's use of major/minor conflicts, formal structures where the same theme comes back over and over, quoted phrases that associate with his song-cycle "Winterreise" and the individual song "Der Wanderer," contrasting keys such as the C and C# regions, and tonal structures where the opening key comes back at the end—I believe that these are all elements of a musical language expressing Schubert's own conception toward life and death. Also, I suggested that the triangle configurations on the *Tonnetz* graphs geometrically represent the wanderer's journey—his soul circling between life and death. In chapter 2, I discussed the nature of

“wandering” that Schubert portrays in his music. The essential quality of such “wandering” is the “construction of the landscape where every point is equally close to the center and equally close to death,” and this quality coincides with the structure of the triangle configurations on the *Tonnetz* graphs. (The triangle holds its center, and also the edges keep a certain distance from the center.) The triangle configurations on the graphs not only depict the wanderer’s path through his journey, but also represent the nature of wandering itself. Every life wanders in the cycle between life and death, where life leads to death, and death leads back to life. In this cycle, every step that the wanderer takes is a moment in which he lives, and the wandering soul lives eternally in the circulation. Each one is given his/her life which has a limit. But within the finite world, every person can live infinitely within the circulation of life and death. The triangles on the graphs are visual representations of such a circulation.

The reversed-triangle configuration which demonstrates the life-theme “wandering,” and the pitch C or the keys C Major/minor which represent the center around which this “wandering” takes place—these ideas are my own suppositions based on my Neo-Riemannian analyses. I believe that these common triangle-configurations appear on the graphs to depict the “wandering” human life that Schubert tries to express in his music. From these configurations, we can visually trace the nature of Schubert’s “wandering,” where a human’s soul wanders in the eternal cycle between life and death. These *Tonnetz* graphs and Schubert’s music itself help me to understand Schubert’s way of life as a “wanderer.” His “wandering” does not mean fighting against fear or suffering. His “wandering” means to accept everything—sorrow, fear, pain and everything else as it is. The wanderer’s journey that Schubert portrays in his music and in his heart is a mental

journey where the protagonist tries to find a way to accept his pain and death. By accepting everything as it is, death turns to new life, and pain turns to love. I strongly feel that the triangles on the graphs I have presented are geometrical representations of a human's wandering soul and the "wanderer" Schubert himself.

APPENDIX
SUPPLEMENTARY TEXT SOURCES

Beach, David W. 1998. "Modal Mixture and Schubert's Harmonic Practice." *Journal of Music Theory*, Vol. 42, No. 1 (Spring): pp. 73–100.

Cohn, Richard L. 2012. *Audacious Euphony*. New York: Oxford University Press.

———. 1998. "Introduction to Neo-Riemannian Theory: A Survey and a Historical Perspective." *Journal of Music Theory*, Vol. 42, No. 2 (Autumn): pp. 167–180.

———. 1997. "Neo-Riemannian Operations, Parsimonious Trichords, and Their "Tonnetz" Representations." *Journal of Music Theory*, Vol. 41, No. 1 (Spring): pp. 1–66.

———. 1996. "Maximally Smooth Cycles, Hexatonic Systems, and the Analysis of Late-Romantic Triadic Progressions." *Music Analysis*, Vol. 15, No. 1 (March): pp. 9–40.

Deutsch, Otto Erich. 1957. *Die Erinnerungen seiner Freunde*. Leipzig: Breitkopf & Härtel.

———. 1958. *Schubert—Memoirs by His Friends*. Translated by Rosamond Ley and John Nowell. New York: The Macmillan Company.

Dineen, Murray. 2005. "Tonal Problem, Carpenter Narrative, and Carpenter Motive in Schubert's Impromptu, Op.90." *Theory and Practice*, Vol. 30: pp. 97–120.

Reed, John. 1997. *Schubert*. New York: Oxford University Press.

REFERENCES CITED

- Adorno, Theodor. 2005. "Schubert". Translated by Jonathan Dunsby and Beate Perry. *19th-Century Music*, Vol. 29, No. 1 (Summer): pp. 3–14.
- . 1982. "Schubert." *Musikalische Schriften IV—Moments musicaux, Impromptus*. Germany: Suhrkamp, pp. 18–33.
- Cadwallader, Allen, and David Gagné. 2011. *Analysis of Tonal Music: A Schenkerian Approach*. Third ed. New York: Oxford University Press.
- Cohn, Richard L. 1999. "As Wonderful as Star Clusters: Instruments for Gazing at Tonality in Schubert." *19th-Century Music*, Vol. 22, No. 3 (Spring): pp. 213–232.
- Cusack, Andrew. 2008. *The Wanderer—in Nineteenth-Century German Literature*. New York: Camden House.
- Deutsch, Otto Erich. 1964. *Schubert—Die Dokumente seines Lebens*. Kassel: Bärenreiter.
- . 1970. *Franz Schubert's Letters and Other Writings*. Translated by Venetia Savile. New York: Books for Libraries Press.
- . 1977. *Schubert—A Documentary Biography*. Translated by Eric Blom. New York: Da Capo Press.
- Dunsby, Jonathan. 2005. "Adorno's Image of Schubert's *Wanderer* Fantasy Multiplied by Ten." *19th-Century Music*, Vol. 29, No. 1 (Summer): pp. 42–48.
- Fisk, Charles. 2001. *Returning Cycles—Contexts for the Interpretation of Schubert's Impromptus and Last Sonatas*. Berkeley and Los Angeles, California: University of California Press.
- Gollin, Edward. 1998. "Some Aspects of Three-Dimensional *Tonnetze*." *Journal of Music Theory*, Vol. 42, No. 2: pp. 195–206.

- Ishii, Seishi. 1997. *Schubert—Pain and Love—*. Akira Kanda. Tokyo: Shunju-sha.
- Kinderman, William. 1997. "Schubert's Piano Music: Probing the Human Condition." *The Cambridge Companion to Schubert*, ed. Christopher H. Gibbs. New York: Cambridge University Press.
- . 1997. "Wandering Archetypes in Schubert's Instrumental Music." *19th-Century Music*, Vol. 21, No. 2 (Fall): pp. 208–222.
- Krebs, Harald. 2003. "Returning Cycles: Contexts for the Interpretation of Schubert's Impromptus and Last Sonatas (Review of Charles Fisk's "Returning Cycles")." *Music Theory Spectrum*, Vol. 25, No. 2 (Fall): pp. 388–400.
- Longman Dictionary of Contemporary English*. 1995. England: Longman Corpus Network.
- Perry, Jeffrey. 2002. "The Wanderer's Many Returns: Schubert's Variations Reconsidered." *The Journal of Musicology*, Vol. 19, No. 2 (Spring): pp. 374–416.
- Pesic, Peter. 1999. "Schubert's Dream." *19th-Century Music*, Vol. 23, No. 2 (Autumn): pp. 136–144.
- Rusch, Rene. 2011. "Rethinking Conceptions of Unity: Schubert's Moment Musical in Ab major, D. 780 (Op. 94) No. 2." *Music Analysis*, Vol. 30, No. 1: pp. 58–88.
- Siciliano, Michael. 2005. "Two Neo-Riemannian Analyses." *College Music Symposium*, Vol. 45: pp. 81–107.
- Solomon, Maynard. 1981. "Franz Schubert's "My Dream"." *American Imago*, Vol. 38, No.2: pp. 137–154.
- Straus, Joseph N. 1990. *Remaking the Past—Musical Modernism and the Influence of the Tonal Tradition*. Cambridge, MA: Harvard University Press.
- Tymoczko, Dmitri. 2009. "Three Conceptions of Musical Distance." *Mathematics and*

Computation in Music, ed. E. Chew, A. Childs, CH Chuan. *Communications in Computer and Information Science*, Vol. 38.

Young, John Bell. 2009. *Schubert—A Survey of His Symphonic, Piano, and Chamber Music*. New York: Amadeus Press.