

# Dundee

# Transportation System Plan



*Update Volume 2*

Prepared for



Prepared by



In association with **Angelo Planning Group**

July 2015

# Volume 2 Contents

---

Volume 2 of the TSP includes all background memos and technical data that was the basis for the Dundee TSP Update.

Memo 1: Public Involvement Plan

Memo 2: Background Document Review

Memo 3: Goals, Objectives, & Evaluation Criteria

Memo 4: Existing Conditions

Memo 5: Future Forecasting

Memo 6: Future Needs Analysis

Memo 7: Stakeholder Interviews #1

Memo 8: Alternatives Evaluation

Memo 9: Stakeholder Interviews #2

Memo 10: Implementing Ordinances

Memo 11: Finance Program

Memo 12: Transportation Standards

# DRAFT MEMORANDUM #1

**DATE:** December 28, 2011

**TO:** Dundee TSP Update Project Management Team

**FROM:** Carl Springer, P.E., DKS Associates  
Ray Delahanty, DKS Associates

**SUBJECT: Dundee Transportation System Plan Update  
Public Involvement Plan**

---

## Project Purpose and Overview

The City of Dundee is undertaking an update to its Transportation System Plan (TSP). The TSP provides guidance for the City, as well as partner agencies and other local stakeholders, about current and future transportation needs, conditions, and proposed improvements. The City's current TSP dates from 2003, and this update will address updated land use assumptions, new transportation assumptions from the Newberg-Dundee Bypass project, and other new and/or amended federal, state, and local plans, policies, and regulations.

## Key Issues

Key transportation planning objectives and issues identified to date include:

- Build upon and incorporate the ideas from previous small-area transportation plans, such as the Main Street Refinement Plan (2006) and the Riverfront District Master Plan (2010).
- Establish a new 2010 TSP baseline and a new 2035 planning horizon.
- Apply the regional traffic model developed by the Oregon Department of Transportation (ODOT)'s Transportation Planning and Analysis Unit (TPAU).
- Address compliance with new and amended federal, state, and local plans, policies, and regulations including the Oregon Transportation Plan (OTP), the state Transportation Planning Rule (TPR), the Oregon Highway Plan (OHP), and the Oregon Greenhouse Gas Reduction Initiative.
- Identify potential new funding sources for the transportation system.
- Study potential changes to existing Dundee street classifications and cross-sections.

## The Role of Public Involvement

Engaging Dundee's citizens and businesses on these and other key issues will be vitally important to the success of the TSP update process. The purpose of this Public Involvement Plan (PIP) is to ensure that the TSP update has broad community support by doing the following:

- Inform and educate stakeholders and the public so they can understand the TSP process and regulatory framework, and can provide constructive input throughout the process.
- Form a Project Advisory Committee (PAC) to directly engage a broad range of community and governmental stakeholders, including key technical, resident, and business interest and perspectives.
- Develop a key stakeholder roster representing key interest groups such as downtown businesses, neighborhood groups, and the development community. Conduct a series of stakeholder interviews to identify specific transportation issues, needs, and possible solutions and to evaluate alternatives once they have been developed.
- Engage the broader community by holding up to three community events to provide information and gather input during the alternatives analysis and to review and comment on the draft TSP update.
- Develop a project website with monthly updates to provide meeting and project information to the general public and local media.

## Project Advisory Committee (PAC)

This group will assist the Project Management Team (PMT) and local decision makers in identifying and addressing community issues throughout the planning effort. At major milestones they will be asked to review the technical work and seek consensus-based recommendations that balance the various community interests and accomplish the objectives of the update process. PAC members will also act as liaisons to the community to help inform constituents about the process and encourage their participation in community outreach events and meetings. Agency technical staff representatives will provide oversight and assistance with interagency coordination, assuring consistency between overlapping plans.

The PAC is expected to represent a range of interest groups, potentially including but not limited to:

- The City of Dundee
- The Oregon Department of Transportation (ODOT)
- Dundee Fire Department
- Newberg School District



- Chehalem Valley Transit
- Yamhill County Road Division

It is expected that the group will meet six times over the course of the project. The City of Dundee will coordinate the formation of the PAC.

### **Community Meetings**

The following public involvement tasks are intended to bring a larger and more inclusive set of participants into the TSP update planning process.

### **Stakeholder Interviews**

The consultant will hold interviews with up to ten (10) stakeholders or stakeholder groups as identified by the City. The interviews will be conducted in two phases, both during Task 5, to identify transportation planning issues and to review and discuss alternative solutions to these issues. Stakeholders will include concerned citizens, business owners, and developers among others. Stakeholders or groups should also include any organized groups that represent low-income, minority, or other potentially disadvantaged populations, consistent with Oregon Title VI Outreach requirements. Other stakeholders could include historic preservation advocates or bicycle and pedestrian advocates. The list may be modified to include other potential stakeholders based on early input from City staff and consultant team.

### **Community Events**

Up to three community events will be conducted for this project. An open house format will be used for each, and City and Consultant staff will cooperatively plan and facilitate the events. Objectives for the three events are as follows:

#### **Community Event #1**

Present an overview of the project purpose and the findings from Technical Memoranda #1 through #6, including existing and future conditions, and preliminary land use and transportation alternatives. Provide written handouts, display boards, and/or other media. Seek input on the goals and objectives of the plan, as well as suggestions for transportation system alternatives to be considered in subsequent technical memoranda and the TSP.

#### **Community Event #2**

Present an overview of the alternatives evaluation and potential recommendations for system improvements using a combination of written materials, display boards, and/or other media. Seek input on alternatives evaluation and recommendations.

#### **Community Event #3**

Present an overview of the Draft TSP using a combination of written materials, display boards, and/or other media, and seek feedback for the recommended TSP.

## Additional Community Outreach

City staff may facilitate additional outreach meetings at local gathering places and with local community groups throughout the process.

## Public Information

### Website

The consultant team will develop and maintain a project Website dedicated to the TSP update. It will include key project information, including a brief overview of the project, meeting dates and summaries, other public involvement opportunities, and project materials. The Website will also provide an opportunity for public comments and questions. The Website will be updated regularly to include new project materials as well as responses to frequently asked questions.

### News Releases and Articles

News releases will be drafted by the consultant team and issued at key points in the process, particularly in advance of community meetings. City staff will provide these releases to the local media, and City staff and consultants will respond to questions and requests from local media representatives for comments or information as needed.

### Mailings and Flyers

Meeting information mailers will be developed prior to each public event. City staff will develop and distribute the mailers with input from the consultant. In addition, City staff will develop flyers to be distributed at several locations within the City and the planning area.

## Tasks and Responsibilities

Task	Description	PI Lead
<b>Public Involvement Plan</b>	Prepare a detailed plan outlining stakeholder outreach methods, advertisement of meetings, distribution of work products, workshop format, and roles and responsibilities.  Comment on and suggest refinements to Plan.	DKS  City
<b>Project Website</b>	Prepare Website content, graphics, layout and information. Initial content should include a planning process description, schedule, opportunities for involvement, and contact information. Regular updates will include answers to frequently-asked questions and current technical and process information, including meeting notices, summaries, maps, and memos.  Provide link from project Website to City	DKS

Task	Description	PI Lead
	<p>Website.</p> <p>Review content before posting to Website.</p>	City and ODOT
<b>PAC Meetings</b>	<p>Develop PAC roster. Form PAC. Provide meeting logistics and notification. Distribute meeting materials.</p> <p>Review PAC roster. Facilitate meetings. Lead presentations. Prepare information and display materials, agendas, summaries, and graphics.</p>	City  DKS
<b>Stakeholder Interviews</b>	<p>Identify up to 10 stakeholders or stakeholder groups to be interviewed during two sets of stakeholder interviews during the project (Task 5).</p> <p>Coordinate interviews with stakeholders and/or stakeholder groups. Work with consultant to schedule meetings and provide any needed materials to interviewees in advance.</p> <p>Review stakeholder interview roster. Conduct interviews. Prepare written summaries of individual interviews as well as an overall summary.</p>	City  City  DKS
<b>Community Events</b>	<p>Coordinate meeting logistics and set-up. Provide staff. Distribute/mail meeting notification information and leave-behinds. Co-facilitate meeting discussions.</p> <p>Prepare meeting notification materials for distribution. Develop meeting format strategy. Prepare handouts, PowerPoint presentation (as needed), and content for display materials. Prepare sign-in sheets and comment cards. Provide staff. Co-facilitate meeting discussions.</p>	City  DKS
<b>Additional Community Outreach</b>	<p>Coordinate and facilitate individual meetings at local gathering places and/or with community groups as needed to supplement scheduled community events. Distribute project materials. Respond to questions during meetings. Prepare brief summary of results.</p>	City
<b>Media Updates</b>	<p>Draft and issue media releases approximately monthly.</p> <p>Distribute media updates and act as project contact to the media.</p>	DKS  City

## Compliance with Title VI Outreach Requirements

Implementation of this Public Involvement Plan will meet requirements and guidance found in ODOT's Title VI (1964 Civil Rights Act) Plan. Specifically, Title VI identifies measures to reach and solicit comments from disadvantaged populations within a community. Although Dundee has relatively limited concentrations of minorities and low-income residents, these populations are present throughout the city.

Based on 2000 census data, the racial makeup of the city was about 92% Caucasian with about 8% of the population classified as Hispanic. This is a higher percentage of Caucasian and lower percentages of nearly all other ethnic groups compared to Oregon as a whole.

Approximately 6.6% of individuals in the city were below the poverty line in 2000, compared to 7.6% for the state as a whole. Though over a decade old, the 2000 figures are still considered relatively accurate, although poverty across the state can be assumed to have increased as a result of the recent recession.

Outreach to low-income and minority populations will be addressed through the following means:

- Make an effort to identify and include low-income and/or minority community members to include on the Project Advisory Committee (PAC) and/or as stakeholders to be interviewed.
- Use a variety of methods of communication as described in the sections above, most of which are accessible to minority and low-income residents.
- Notify agencies that work with low-income and minority populations about opportunities for public involvement.
- Notify representatives from Native American tribes in the region such as the Confederated Tribes of the Grand Ronde, Confederated Tribes of Siletz Indians, Confederated Tribes of Warm Springs, Clatsop-Nehalem Confederated Tribes, and the Chinook Indian Nation.
- Hold meetings in places that are accessible by transit, walking, or bicycling.
- The City will offer ADA assistance (e.g. accessibility, hearing assistance) and translation services as needed at meetings, given prior notice.



## MEMORANDUM #2

**DATE:** January 27, 2012

**TO:** Dundee TSP Update Project Management Team

**FROM:** Darci Rudzinski, AICP, Angelo Planning Group  
Shayna Rehberg, AICP, Angelo Planning Group

**SUBJECT: Dundee Transportation System Plan Update  
Background Document Review**

---

### Overview

This memorandum summarizes the planning documents, policies, and regulations that are applicable to the City of Dundee Transportation System Plan (TSP) update. The City's current TSP will serve as the foundation for the update process, upon which new information obtained from system analysis and stakeholder input will be applied to address changing transportation needs through the year 2035, resulting in a new and updated TSP. Proposed new strategies for addressing transportation needs will need to be compliant and coordinated with the plans, policies, and regulations described herein.

### Transportation System Planning in Oregon

Transportation System Planning in Oregon is required by state law as one of the 19 statewide planning goals<sup>1</sup> (Goal 12 – Transportation). The Transportation Planning Rule (TPR), OAR 660-012<sup>2</sup>, defines how to implement State Planning Goal 12. Specifically, the TPR directs the State to prepare a TSP, referred to as the Oregon Transportation Plan (OTP); Metropolitan Planning Organizations (MPOs) to prepare a Regional Transportation Plan (RTP) that is consistent with the OTP; and Counties and Cities to prepare local TSPs that are consistent with the OTP and RTP.

The TPR requires TSPs to integrate comprehensive land use planning with transportation planning and to promote systems that serve statewide, regional and local transportation

---

<sup>1</sup> Statewide Planning Goals: <http://www.oregon.gov/LCD/goals.shtml>

<sup>2</sup> Transportation Planning Rule: [http://arcweb.sos.state.or.us/rules/OARS\\_600/OAR\\_660/660\\_012.html](http://arcweb.sos.state.or.us/rules/OARS_600/OAR_660/660_012.html)

needs. State transportation requirements aim to improve community livability by encouraging land use patterns and transportation systems that make it more convenient and efficient for people to walk, bicycle, use transit and drive less to meet their daily needs.

The OTP<sup>3</sup>, as the guiding document for regional and local TSPs, establishes goals, policies, strategies and initiatives that address the core challenges and opportunities facing transportation in Oregon. The OTP prioritizes:

- Maintaining and maximizing assets already in place;
- Optimizing the performance of the existing system through technology;
- Integrating transportation, land use, economic development and the environment;
- Integrating the transportation system across jurisdictions, ownerships and modes;
- Creating sustainable funding; and
- Investing in strategic capacity enhancements.

OTP guidance is further implemented by adopted standards in the Oregon Highway Plan (OHP).<sup>4</sup>

### Why does Dundee need an Updated TSP?

The City's current TSP was adopted in 2003. Since then amendments have been made to the OTP, OHP, and other state regulations, plans for the Newberg-Dundee Bypass have progressed, and other local vision and master plans have been developed. The last 10 years of regulatory, land use, and transportation system changes will guide and be incorporated in this TSP update.

**ODOT's Transportation System Plan Guidelines**<sup>5</sup> document directs TSP updates to address recent policy and regulatory changes, and calls out some of the recent changes to the OTP, OHP, TPR. Since adoption of the 2003 Dundee TSP, the OTP was updated (2006) to emphasize maintaining assets in place, optimizing existing system performance through technology and better system integration, creating sustainable funding, and investing in strategic capacity enhancements. Policy 1F (Mobility Standards) of the OHP was amended in 2011 to clarify that the adoption of alternative mobility standards is permitted where it is "infeasible or impractical to meet the mobility targets."<sup>6</sup> Appendix C (Access Management

---

<sup>3</sup> Oregon Transportation Plan: <http://www.oregon.gov/ODOT/TD/TP/ortransplanupdate.shtml>

<sup>4</sup> Oregon Highway Plan: <http://www.oregon.gov/ODOT/TD/TP/orhwyplan.shtml>

<sup>5</sup> ODOT Transportation System Plan Guidelines: <http://www.oregon.gov/ODOT/TD/TP/TSP.shtml>

<sup>6</sup> Note that the mobility targets included in the Highway Mobility Policy must be used for the initial deficiency analysis of state highways. However, state policy allows that, where it can be shown that it is infeasible or impractical to meet the targets, local governments may work with ODOT and stakeholders to consider and

Spacing Standards) has also been updated to be consistent with amendments to the Access Management Rule, OAR 734-051.<sup>7</sup>

## How is the Transportation System Defined?

The following sections summarize the state highway classifications and applicable state policies for state facilities through Dundee. This information guides planning for these facilities and ultimately determines the adopted standards and regulations that apply to state highways in Dundee.

### ODOT Classifications for State Highways in Dundee

**Highway Classifications:** OHP Policy 1A categorizes state highways for planning and management decisions. Updates to the TSP will support the existing highway classifications and will enhance the ability of the highways in Dundee to serve transportation needs consistent with their defined functions. The following classifications apply to state facilities in Dundee:

- OR 99W (Pacific Highway West, No. 91/1W) is classified as a Statewide Highway, part of the National Highway System (NHS), a Truck Route, and a Freight Route. Statewide highways primarily serve inter-urban and inter-regional travel and strive to provide safe and efficient, high-speed operation with minimal access and interruption. Operation may be affected by special land use designations described below.
- Newberg-Dundee Bypass (to be constructed) is expected to be classified as a Bypass and Expressway. Expressways are characterized by limited access. The primary purpose of expressways is to serve interurban travel and provide for high-speed and high-volume traffic with minimal access and interruption.

**Special Designations:** OHP Policy 1B permits special highway segment designations where specific types of land use patterns foster compact development and in areas where the need for appropriate local access outweighs the considerations of highway mobility. Currently, there are no Special Transportation Area (STA) designations on OR 99W in Dundee. Such designations may be considered during the TSP update or subsequent planning processes to acknowledge that the highway serves as Dundee's main street and that mobility and through traffic needs must be balanced with local access needs. Within an STA designation, which must be adopted as part of the OHP, access spacing standards can be modified and speeds reduced. While an STA designation may be appropriately considered for OR 99W through

---

evaluate alternatives to the mobility targets in Tables 6. Any variance from the targets in Tables 6 requires Oregon Transportation Commission adoption.

<sup>7</sup> Amendments to OAR 734-051 were made by SB 264 (2011) and went into effect on January 1, 2012. <http://www.leg.state.or.us/11reg/measpdf/sb0200.dir/sb0264.en.pdf>

Dundee, the OHP specifies that the future Newberg-Dundee Bypass, as an Expressway, may not be designated as an STA.

**State Highway Freight System:** OHP Policy 1C addresses the need to balance the movement of goods and services with other uses. It states that the timeliness of freight movements should be considered when developing and implementing plans and projects on freight routes. Within Dundee, OR 99W is classified as a Federal Truck Route and an Oregon Freight Route. This classification could change with the completion of the Newberg-Dundee Bypass.

## How is the Transportation System Managed?

**State Highway Mobility Standards:** OHP Policy 1F sets mobility targets for ensuring a reliable and acceptable level of mobility on the highway system<sup>8</sup>. The OHP assesses mobility in terms of volume to capacity ratio (v/c). The following mobility targets are applicable to long-range planning for state highways in Dundee during peak hour operation<sup>9</sup>, pursuant to Policy 1F, Table 6:

- 0.85 v/c for Statewide Highways that are Freight Routes inside a UGB, outside of a MPO and STA, where the posted speed is 35 mph or less (OR 99W).<sup>10</sup>
- 0.80 v/c for Statewide Expressways and Statewide Highways that are Freight Routes inside a UGB, outside of a MPO and STA, where the posted speed is greater than 35 mph (OR 99W and future Newberg-Dundee Bypass).

It is anticipated that the findings of the transportation analysis for the TSP update will support a change to mobility targets for 99W within the city; the TSP update process is an opportunity to develop and apply alternative mobility targets. The Oregon Transportation Commission (OTC) must approve proposed alternative mobility targets on state highways.

**City and County Mobility Standards:** The City of Dundee TSP<sup>11</sup> identifies Level of Service (LOS) “D” as the minimum performance standard for all streets owned and operated by the

---

<sup>8</sup> In particular, the mobility targets in Table 6 of OHP Policy 1F are applicable to state facilities in Dundee and are considered standards for purposes of determining compliance with Transportation Planning Rule (OAR 660-012).

<sup>9</sup> OHP Policy 1F uses the 30th highest annual hour as the peak hour. Alternatives to the 30th highest annual hour may be established as part of adopting an alternative mobility target.

<sup>10</sup> The Dundee City Council recently approved a recommendation by the ODOT speed zone investigator to change the speed from 35 mph to 30 mph on 99W through Dundee. ODOT is waiting for confirmation from the City of Newberg, which is currently considering recommendations pertaining to 99W in Newberg. A speed zone order from ODOT will be issued at the end of the review process.

<sup>11</sup> Dundee TSP (2003), p.98, Policy A.11 under General Transportation Network Policies.



City during the 20-year planning period. As current TSP policy states: “When the LOS drops to ‘E’, actions will be initiated to return the street to LOS ‘D’.” Similarly, the Yamhill County TSP<sup>12</sup> requires LOS “D” as the minimum acceptable performance standard for County-owned collectors and arterials. Local LOS standards will be reviewed as part of the TSP update.

**Access Management on State Highways:** The Oregon Access Management Rule<sup>13</sup> (OAR 734-051) strives to balance the safety and mobility needs of travelers along state highways with the access needs of property and business owners. ODOT’s rule sets guidelines for managing access to the state’s highway facilities in order to maintain highway function, operations, safety, and the preservation of public investment consistent with the policies of the 1999 OHP. Access management rules allow ODOT to control the issuing of permits for access to state highways, state highway rights of way and other properties under the State’s jurisdiction.

In addition, the ability to close existing approaches, set spacing standards and establish a formal appeals process in relation to access issues is identified. These rules enable the State to set policy and direct the location and spacing of intersections and approaches on state highways, ensuring the relevance of the functional classification system and preserving the efficient operation of state routes.

OAR 734-051 is in the process of being amended to allow more consideration for economic development when developing and implementing access management rules. The new laws will result in substantial changes in rules about how ODOT manages highway approach road permitting. Changes include modifying how ODOT deals with approach road spacing, highway improvement requirements with development, and traffic impact analyses requirements for approach road permits. The law’s provisions went into effect on January 1, 2012.

OHP Policy 3A and OAR 734-051 set access spacing standards for driveways and approaches to the state highway system.<sup>14</sup> The standards are based on state highway classification and differ based on posted speed. The administrative rule is in the process of being amended; the following spacing standards are in effect for unsignalized approaches to

---

<sup>12</sup> Yamhill County TSP, Goals and Policies 1, Chapter 5 – Transportation System Plan, Section 5.2 – Collector/Arterial Street Plan, Subsection 5.2.4 – Level of Service

<sup>13</sup> Access Management Rule: [http://arcweb.sos.state.or.us/rules/OARS\\_700/OAR\\_734/734\\_051.html](http://arcweb.sos.state.or.us/rules/OARS_700/OAR_734/734_051.html)

<sup>14</sup> ODOT Access Management Standards (Appendix C):  
<http://www.oregon.gov/ODOT/TD/TP/orhwyplan.shtml>

statewide highways in urban areas where average daily traffic is more than 5,000 motor vehicles.<sup>15</sup>

**Table 1: Spacing Standards for Urban Non-Designated Statewide Highways (OR 99W)**

Posted Speed (mph)	Spacing (feet)
55 and higher	1,320
50	1,100
40-45	800
30-35	500
25 and lower	350

**Access Management on Local Roadways:** The existing Dundee TSP, Dundee Development Code, and Yamhill County TSP provide access spacing standards and guidelines for public roadways under City and County jurisdiction. Access spacing guidelines from the Dundee TSP are as follows:

- Local streets shall be spaced at a maximum 600 feet apart, unless accessing OR 99W, where state access spacing requirements apply.
- Collectors shall be located wherever necessary to carry traffic volumes higher than local street standards, or where the street provides primary access to OR 99W. In general, collectors should be spaced at a maximum ¼ mile apart.<sup>16</sup>

The Dundee Development Code includes specific standards for City streets.<sup>17</sup>

**Table 2: Minimum Spacing Standards for City Streets**

Street Classification	Spacing (feet)
Arterial	150 (+/- 20%)
Collector	75
Local	15

<sup>15</sup> Table 2 in SB 264, <http://www.leg.state.or.us/11reg/measpdf/sb0200.dir/sb0264.en.pdf>

<sup>16</sup> 2003 Dundee TSP, Transportation System Plan (Chapter 6), pp. 108-109.

<sup>17</sup> Development Code, Section 2.202.08, Access Management

Yamhill County owns the following five roads in Dundee: Fox Farm Road, Dayton Avenue, 9<sup>th</sup> Street-Worden Hill Road, Niederberger Road, and Fulquartz Landing Road.<sup>18</sup>

The policy statements below from the Yamhill County TSP guide access management on County-owned arterials in urban areas.

- Public road access spaced at a minimum of 1/2 mile apart.
- Driveways spaced at a minimum of 500 feet apart.
- Traffic signals spaced at a minimum of 1/2 mile apart, and no median control.<sup>19</sup>

County policy states that environmental conditions and safety conditions are amongst the factors considered in taking an exception to these policies.

**Major Improvements:** OHP Policy 1G requires maintaining performance and improving safety by improving efficiency and management before adding capacity. The intent of policy 1G and Action 1G.2 is to ensure that major improvement projects to state highway facilities have been through a planning process that involves coordination between state, regional, and local stakeholders and the public, and that there is substantial support for the proposed improvement.

**Off-System Improvements:** OHP Policy 2B establishes ODOT's interest in improvements on local roads that maintain or improve safety and mobility performance on state roadways, and supports local jurisdictions in adopting land use and access management policies. The TSP will include sections describing existing and future land use patterns, access management, and implementation measures.

**Traffic Safety:** OHP Policy 2F identifies the need for projects in the state to improve safety for all users of the state highway system through engineering, education, enforcement, and emergency services. One component of the TSP update is to identify existing crash patterns and rates and to develop strategies to address safety issues. Proposed improvements will aim to reduce the vehicle crash potential and/or improve bicycle and pedestrian safety by providing upgraded facilities that meet current standards.

**Alternative Passenger Modes:** OHP Policy 4B, Action 4B.4 requires that highway projects encourage the use of alternative passenger modes to reduce local trips. The TSP will develop ways to support and increase the use of alternative passenger modes to reduce trips on highways and other facilities. This will include improvements to bicycle and pedestrian facilities and consideration of existing and future transit movement along roadways.

---

<sup>18</sup> 2003 Dundee TSP. Existing Conditions (Chapter 3), p. 31

<sup>19</sup> Yamhill County TSP, Access Management and Functional Classification Policy 8

**Improvements on State Highways:** The Highway Design Manual<sup>20</sup> (HDM) provides uniform standards and procedures for ODOT and is in general agreement with the 2001 American Association of State Highway and Transportation Officials (AASHTO) *A Policy on Geometric Design of Highways and Streets*. Some key areas where guidance is provided are the location and design of new construction, major reconstruction, and resurfacing, restoration or rehabilitation (3R) projects. The HDM should be used for all projects on state highways in Dundee to determine design requirements, including the maximum allowable volume to capacity ratios for use in the design of highway projects.

## Other Background Information for the TSP Update

The following sections summarize additional background information or guidance documents that will be referenced in updating the Dundee TSP.

### Projects to Be Considered in Future Transportation Analysis

Several of the documents reviewed identified transportation improvement projects that will be considered in future transportation analysis in Dundee. Relevant projects are found in the following documents.

#### Approved 2010-2013 Statewide Transportation Improvement Program (STIP)<sup>21</sup>

- OR-18/Newberg – Dundee Bypass (Key Number: 12819): Funding for acquisition of right-of-way to preserve alignments in the bypass corridor adopted through the Location Environmental Impact Statement (LEIS). Sufficient funding has already been programmed for the design/construction level EIS for the bypass.

#### Newberg-Dundee Bypass Tier 2 Draft Environmental Impact Statement (2010)

The Newberg-Dundee Bypass is planned as a four-lane, 11-mile, controlled access expressway proposed by ODOT and the Federal Highway Administration (FHWA). The alignment and design options are based on many years of planning and coordination with Yamhill County and the cities of Newberg and Dundee. The facility is proposed to bypass the central portions of Newberg and Dundee to relieve traffic congestion and allow for downtown revitalization and enhancement in these communities. A Tier 2 Draft Environmental Impact Statement (DEIS) has been completed for the proposed bypass.

Four interchanges are proposed including a Dayton Interchange at the junction of OR 99W and OR 18, an East Dundee Interchange within the Dundee UGB, an OR 219 Interchange at the edge of the Newberg UGB, and an East Newberg Interchange.

---

<sup>20</sup> ODOT Highway Design Manual:

[http://www.oregon.gov/ODOT/HWY/ENGSERVICES/hwy\\_manuals.shtml](http://www.oregon.gov/ODOT/HWY/ENGSERVICES/hwy_manuals.shtml)

<sup>21</sup> ODOT STIP: <http://www.oregon.gov/ODOT/HWY/STIP/>



The Build Alternative developed through the Tier 2 DEIS process divides the bypass into nine segments. Segments 2, 3, and 4 span from the Dayton Interchange to the Dundee UGB, and from the Dundee UGB to the East Dundee Interchange just north of the UGB. The following summarizes the improvements that are proposed for Segments 2, 3, and 4.

**Segment 2** – At-grade roadway with local circulation improvements that reconnect Riverwood Road, Fulquartz Landing Road west/east, and Crawford Lane to OR 99W, which will be disconnected by construction of the bypass and are located on the eastern edge of the Dundee UGB.

**Segment 3** – Design options involve below-grade or at-grade roadway, with and without six to eight-foot berms. Local circulation improvements for all design options involve bypass overcrossing options at either 6<sup>th</sup>, 8<sup>th</sup>, or 10<sup>th</sup> Street, all located within Dundee.

**Segment 4** – Design options for East Dundee Interchange are either a diamond interchange or partial cloverleaf interchange in the Riverside Master Plan study area (also indicated through land identified as Columbia Empire Farms<sup>22</sup>). Local circulation improvements for both options involve an East Dundee connector road that re-aligns Fox Farm Road and Dayton Avenue to connect with OR 99W.

ODOT has made recommendations on design options. For Segment 3, ODOT recommends the bypass be at-grade with six to eight-foot berms and the 8<sup>th</sup> Street overcrossing (Design Option 3.B2). For Segment 4, ODOT recommends a diamond interchange (Design Option 4.1). ODOT and the City have been working on crossing locations.

#### **Newberg-Dundee Bypass Phase 1 Technical Report Addendum**

ODOT is evaluating options for the first phase of construction of the Newberg-Dundee Bypass.<sup>23</sup> Phase 1 will entail construction of a two-lane roadway (one lane in each direction) extending from OR 219 in Newberg to OR 99W south of Dundee. The western connection will occur at either a directional interchange near Fulquartz Landing Road/OR 99W, well south of the Dundee UGB, or at an at-grade signalized intersection with OR 99W just to the south of the Dundee UGB. No intermediate interchanges along the bypass will be constructed as part of Phase 1 and, other than the Phase 1 western connection of the bypass to OR 99W, none of the proposed opening year (2016) mitigation measures are located in Dundee.

---

<sup>22</sup> This property is outside the Riverside Master Plan study area, and outside the UGB/city limits.

<sup>23</sup> Phase 1 Technical Report Addendum, Kittelson & Associates, September 2011. The final version of the Riverside Master Plan District (Ord no. 503-2011) is found in the City's ordinance table in the Dundee Municipal Code: <http://codepublishing.com/OR/Dundee/>

### Dundee Capital Improvement Plan

The City does not have a current Capital Improvement Plan (CIP). Transportation projects developed as part of the TSP update can serve as a transportation CIP for the city.

### Dundee Riverside Master Plan (2010)

The Dundee Riverside Master Plan consists of a land use and transportation plan and implementing development regulations for roughly 400 acres in Southeast Dundee. Land uses envisioned in the master plan include a large amount of land for parks, open space, and a trail network as well as residential development and non-residential development including smaller-scale neighborhood commercial uses and larger-scale “destination” uses such as wineries, event facilities, a hotel, golf course, restaurants, and related uses.

The master plan includes transportation policies and phasing requirements<sup>24</sup> as well as roadway cross sections for local streets, parkway collectors, and collector streets<sup>25</sup>.

Conceptual projects are shown in the plan<sup>26</sup> and include:

- 5<sup>th</sup> Street extension, including bypass overpass
- North South Parkway
- Chehalem Heritage Trails
- Greenway Trail

The Riverside Master Plan planning process deliberately excluded developing a local street system for the area. The expectation is that the local street system will be developed as part of development plans and will be consistent with adopted city standards.

### Dundee Main Street Refinement Plan (2006)

The Dundee Main Street Refinement Plan was prepared in anticipation of enhancements that could be made to downtown once the Newberg-Dundee Bypass was constructed. The plan is not an adopted City document but represents important past visioning and policy work on the part of the community and community partners.

The plan consists primarily of a land use concept plan and a set of street design guidelines (a “main street plan”). Elements of the land use concept plan and design guidelines include the following ideas:

---

<sup>24</sup> Transportation policies and phasing requirements are found on pp. 18-19 and pp. 21-22 of the final version of the Riverside Master Plan, <http://www.dundeeriverfront.net/>. [Note: Version 5, but not the final version, is provided on the project website.]

<sup>25</sup> Figure 4 (Standard Cross Sections for Local Streets) and Figure 5 (Standard Cross Sections for Parkway Collector and Collector Streets)

<sup>26</sup> Figure 3 (Riverside District Transportation Framework Plan)

- The downtown core is between 5<sup>th</sup> Street and 10<sup>th</sup> Street, with gateways envisioned at these boundaries.
- The road through downtown should be three lanes, with wider sidewalks, bicycle facilities, on-street parking, and landscaping.
- Uses should be mostly retail, with minimal to no setbacks and no driveways in between buildings. Passive open spaces (courtyards/plazas) should be located throughout the retail areas.
- Off-street parking should be accessed from side streets.
- There should be a network of pedestrian and bicycle “green” corridors down to the Willamette River and circling town.
- A town square should be developed at either the historic railroad depot or on the corner of 5<sup>th</sup> and OR 99W, to be the site of a farmers market and other community activities.

The plan recommends different applications and treatments pertaining to speed limits, on-street parking, raised medians, planters, curb extensions, sidewalks, and bicycle lanes depending on the roadway segment designations of Downtown Core, Transition, Suburban, and Rural. It proposes local connectivity improvements as well as “interim” improvements and strategies to help mitigate conditions on OR 99W until the bypass is built.

#### **Dundee Oregon 99W Interim Measures Report (2006)**<sup>27</sup>

The Interim Measures Report presents ODOT recommendations to mitigate some of the congestion along OR 99W in Dundee until the bypass is constructed. Of several project ideas evaluated, ODOT recommended the following three sets of ideas.

- Traffic signals at 9th-10th – Signals intended to facilitate local off-highway traffic circulation.
- Commuter Bus Service – The Yamhill County Transit Committee approved a transit plan recommending park-and-ride lots.<sup>28</sup> The Bypass Project Management Team was charged with working on funding options.
- Dundee Intra-city Connectivity Improvements at Red Hills Road, Fairview Road, and Fulquartz Landing Road – These improvements are feasible for local traffic, but need funding.

---

<sup>27</sup> Note: This document was not in the project scope of work but summarized information from this report is included here due to its possible relevance to the TSP update.

<sup>28</sup> The Yamhill County Transit Area adopted the Yamhill County Public Transportation Action Plan in June 2004. [Note: This plan is not available online.] It was followed by the Yamhill County Coordinated Human Services Public Transportation Plan (2007), <http://www.yctransitarea.org/pdf/COORDINATEDPLAN.PDF>.

## Actions or Strategies to Be Considered in Updating the TSP

Several of the documents reviewed identify transportation actions, strategies, or standards and guidelines that will be considered in updated the Dundee TSP. Relevant actions or strategies include those found in the following documents.

### Oregon Freight Plan (2011)

The Oregon Freight Plan (OFP) is a modal plan of the OTP that implements the State's goals and policies related to freight. Its purpose statement is: "to improve freight connections to local, Native American, state, regional, national and global markets in order to increase trade-related jobs and income for workers and businesses."

The objectives of the plan include creating a framework for prioritizing and facilitating investments in freight facilities (including rail, marine, air, and pipeline infrastructure) and adopting strategies to maintain and improve the freight transportation system.

The plan identifies and defines four multimodal corridors whose connectivity is vital to the state economy. OR 99W is a state facility that provides connectivity in one of those corridors, the Western Corridor.

The plan includes a set of 11 strategies and corresponding actions that address defining and preserving a strategic freight system, reviewing investment criteria, establishing procedures to ensure system safety and efficiency, partnering with other organizations, coordinating freight planning with land use planning and other regulatory programs, and dealing with long-term funding needs.

Newly adopted, the plan still needs to develop and take action on implementation measures including an overall implementation plan, performance measures, funding options, and outreach regarding bottlenecks and choke points on the strategic freight system.

While freight needs on OR 99W will largely be alleviated once the bypass is constructed, this TSP update will be coordinated with any Freight Plan implementation measures that may be developed and enacted during the TSP update process. Because OR 99W is currently a designated Freight Route, the requirements of ORS 366.215 also apply. This State Statute states, with specific exceptions, that the Oregon Transportation Commission may not permanently reduce the vehicle-carrying capacity of an identified freight route.<sup>29</sup>

### Oregon Bicycle and Pedestrian Plan (1995; 2007 draft update)

The goal of the Oregon Bicycle and Pedestrian Plan is to provide safe and accessible bicycling and walking facilities in order to encourage increased levels of bicycling and walking. The plan provides measures that will assist local jurisdictions in understanding the

---

<sup>29</sup> This statute implements a no Reduction of Vehicle-carrying Capacity (RVC) policy and pertains to all planning, project development, development review and maintenance projects. See ODOT's Guidelines for Implementation of ORS 366.215 <http://www.oregon.gov/ODOT/TD/TP/ORS366.215.shtml>.



principles and policies that ODOT follows in providing bike and walkways along state highways. In order to meet the plan's objectives, strategies for system design include providing bikeway and walkway systems that are integrated with other transportation systems; providing a safe and accessible biking and walking environment; and developing education programs that improve bicycle and pedestrian safety.

The plan states that bikeway and walkway systems will be established on urban highways, as follows:

- As part of modernization projects (bike lanes and sidewalks will be included);
- As part of preservation projects, where minor upgrades can be made;
- By restriping roads with bike lanes;
- With minor improvement projects, such as completing short missing segments of sidewalks;
- As bikeway or walkway modernization projects;
- By developers as part of permit conditions, where warranted.

The 1995 document includes two sections, including the *Policy & Action Plan* and *Bikeway & Walkway Planning Design, Maintenance & Safety*. The first section contains background information, legal mandates and current conditions, goals, actions, and implementation strategies ODOT proposes to improve bicycle and pedestrian transportation. The second section assists ODOT, cities, and counties in designing, constructing and maintaining pedestrian and bicycle facilities. The document recommends design standards and provides safety information.

The second section has been updated as a new Oregon Bicycle and Pedestrian Design Guide addressing on-road bikeways, restriping, bicycle parking, walkways, street crossings, intersections, and shared-use paths.<sup>30</sup> Once adopted, the updated Oregon Bicycle and Pedestrian Plan Design Guide will be referenced where bicycle or pedestrian facilities are planned as part of state funded projects or facilities.

#### **Oregon Public Transportation Plan (1997)**

The Oregon Public Transportation Plan serves as the transit modal plan of the OTP. The plan builds on and implements the OTP's long-range vision for public transportation in the State of Oregon. The vision includes a comprehensive, interconnected, and dependable public transportation system, with stable funding, that provides appropriate service in each area of the state, offers an attractive option to driving to meet daily needs, and supports livability and economic development in the state.

---

<sup>30</sup> A July 2007 public review draft is available on ODOT's website: at: [http://www.oregon.gov/ODOT/HWY/BIKEPED/bp\\_plan\\_update.shtml#Background\\_Information](http://www.oregon.gov/ODOT/HWY/BIKEPED/bp_plan_update.shtml#Background_Information)

The plan contains goals, policies, and strategies relating to the whole of the state's public transportation system. The plan is intended to provide guidance for ODOT and public transportation agencies regarding the development of public transportation systems.

The Yamhill County Transit Committee addresses transit issues in Dundee and Yamhill County. Since adoption of the 2003 Dundee TSP, the Yamhill County Transit Area (YCTA) was formed to provide countywide service by contracting with Yamhill County Community Action Partnership (YCAP) and CVSCC (Chehalem Valley Senior Citizens Council). The organizations provide daily service between Tigard and McMinnville in Yamhill County. YCTA plans include the Yamhill County Public Transportation Action Plan (2004) and Yamhill County Coordinated Human Services Public Transportation Plan (2007).<sup>31</sup> This transportation planning process will be coordinated with the County's transit plan and the updated TSP will include a transit element.

#### **Dundee Comprehensive Plan (1977)**

The Dundee Comprehensive Plan addresses Statewide Planning Goals and guides the city's future long-term growth and development. The plan is generally organized according to the statewide goals, presenting existing and forecasted conditions, objectives, and policies for each goal.

Urbanization, economic development, and transportation goals are particularly relevant to transportation planning in Dundee. Urbanization goals are reflected in the Comprehensive Plan Map, which in turn guides zoning and establishes the city limits and UGB for Dundee. Economic development policies call for diversifying the local economy by providing more land for light industrial development; improving the business environment along OR 99W by supporting highway projects that reduce congestion, requiring off-street parking, and establishing high design standards; and controlling strip commercial development. Transportation goals and policies in the Comprehensive Plan, including those addressing the general transportation network, the bypass, pedestrian and bicycle facilities, public transportation, and rail and pipelines, were updated in 2003, 2004, and 2010. A subsequent 2010 update consisted only of amendments to bypass policies, including identification of preferred bypass alternatives, determination of planned improvements for TPR compliance, specification of IAMP requirements, planning crossings of the bypass, and protection of bypass function and surrounding rural land. Adopted transportation policies will be reevaluated as part of the TSP update; new recommended policies will need to be made consistent with other, related policies in the Comprehensive Plan.

---

<sup>31</sup> [Note: The Yamhill County Public Transportation Action Plan (2004) is not available online.] Yamhill County Coordinated Human Services Public Transportation Plan (2007)  
<http://www.yctransitarea.org/pdf/COORDINATEDPLAN.PDF>

### Dundee Development Code

The Development Code implements the Comprehensive Plan by providing descriptions of zone designations, allowable uses within those zones, and development regulations. Zone designations in the city include agricultural, residential, commercial, destination resort, light industrial, and public base zones. The Development Code also establishes overlay zones, including the Flood Plain, Greenway Management, and Commercial Victorian Overlay Zones. The Zoning Map shows the location of zone designations and consequently helps direct the type, location, and density of land uses in the city.

The following is an overview of code sections that may need to be updated in order to be consistent with the findings and recommendations of the updated TSP.

- Site Development Review (Section 3.105) is required for all new development or expansion and remodel projects that increase total floor area by 25% or more, except for single-family homes and duplexes. Site plan standards include requirements for transportation circulation patterns, access, and parking.
- Street standards (Section 2.202) addresses future street extensions, fees in lieu of street improvements, new streets, general right-of-way and improvement widths, cul-de-sacs, private streets, and access management. Specific street design standards and cross-section diagrams are found in the TSP (Figure 6-2), as well as the Riverside Master Plan.
- Off-street parking and loading provisions (Section 2.203) address requirements for location, joint use, dimensions, and number of spaces for motor vehicle parking. This section also establishes requirements for the number of spaces and design of bicycle parking.
- The code sections on development standards cover several transportation elements. Block standards (Section 2.208.04) include requirements for block length, other connectivity elements, and bicycle and pedestrian accessways. Improvement requirements (Section 2.208.05) address frontage improvements, streets, sidewalks, and curb cuts.
- Review criteria for subdivisions and Planned Unit Developments (PUDs) (Section 3.107.03) and for zone changes (Section 3.102) include requirements for adequate public facilities. Traffic impact studies are not explicitly required as part of meeting these requirements.
- Public notice requirements (Section 3.202) specify that agencies with jurisdiction of roadways within 100 feet of application sites shall receive notices of Type I, II, and III hearings and decisions.

### Dundee Public Works Design Standards

The City of Dundee has public works design standards that address general requirements for the construction of public facilities, including streets and procedures for design

modifications<sup>32</sup>, and a specific section on streets<sup>33</sup>. The streets section addresses minimum right-of-way and pavement widths according to functional classification as well as requirements for cul-de-sacs, sidewalks, bikeways, and parking lots. It is expected that any recommended changes made to street and transportation standards through the TSP update process will need to be reflected in these public works standards documents.

#### **A Vision for Highway 99W in Dundee, Final Report from a Public Workshop (2011)**

The Vision Plan focuses on land use and urban design in the OR 99W corridor, and in Dundee in particular. The vision for this part of the corridor is to create:

*[...] an attractive and safe “community corridor” that incorporates new buildings along with pedestrian and bicycle amenities into the existing business district to create a character unique to Dundee. The vision includes a town center off of Highway 99W to complement the corridor and provide a Main-street feel and community gathering space [...]*

The plan envisions a community corridor that is identified by gateways; concentrates retail uses into centers at key intersections; creates a distinct urban form through setbacks, courtyards, and back entrances; locates parking to the sides and rear of buildings; and provides an attractive streetscape and buffer to the highway.

According to the plan, the town center should include a mix of land uses (including local shops, neighborhood services, small-scale offices, and second-story apartments), gathering spaces, storefronts built right up to the sidewalk, an inviting pedestrian environment, and parking to the sides or rear of buildings.

Next steps identified in the plan direct the City to develop an overall implementation strategy, prepare integrated land use and transportation plans for the corridor and town center, amend the Development Code for site and building design standards in the corridor, secure funding for streetscape improvements, and revise the Vision Plan annually. One of the objectives of this TSP update is to develop a transportation system that is consistent with the land use objectives of creating a town center. Proposed amendments to the Development Ordinance will be developed during the TSP update process in order to comply with transportation and TPR requirements. While these amendments may not entirely fulfill the land use planning “next steps” recommended by the Vision Plan, any proposed ordinance amendments will be consistent with the Vision Plan.

#### **Dundee Historic Resources and Local Wetland Inventory and Riparian Assessment (Goal 5)**

The City has provided GIS data that includes historic, local wetland, and riparian resources to inform the transportation system analysis and recommendations.

---

<sup>32</sup> City of Dundee Public Works Design Standards, Division 1

<sup>33</sup> City of Dundee Public Works Design Standards, Division 2

### Recently Constructed Transportation Projects

The following transportation improvements have been made in the city since adoption of the 2003 TSP.

1. The Arrowhead, Tomahawk and View Crest streets (including sidewalks both sides) were completed as part of subdivision development. There are no sidewalk gaps.
2. Highway frontage improvements, Neiderberger, Alder (including curbs and sidewalks) next to West End buildings project. The City paid the developer to complete curb and sidewalk improvements (quarter street improvements) to the west side of Alder Street across from the project.
3. Widening of 11th Street, a City project funded by a SCA grant. Curbs and sidewalks completed on south side of 11th Street between James Court and OR 99W. Curbs completed on north side of 11th Street between Alder Street and OR 99W, and sidewalks completed except about 200 feet eastward from Alder Street where the right-of-way is 50 feet wide.
4. Complete sidewalk on south side of 5th Street between Locust and Edwards (part of SCA grant) and complete curb and sidewalk on west side of Edwards between 5th and 8th (ARRA grant).
5. 5th Street/OR 99W intersection traffic signal project (ODOT), includes new turning lane on 5th Street eastbound approaching 99W, new sidewalk on the east side of 99W from a point about 300 feet south of 5th Street (Argyle Winery property) to the 4th Street intersection.
6. New streets, Graystone Drive and Graystone Place, pedestrian path connection between Graystone Place and 5th Street, new curb and sidewalk on the north side 7th Street, and new curb on the south side of 5th Street and the east side of Upland Drive, and curb and sidewalk on the west side of Upland Drive as part of a subdivision. Infill sidewalks are being installed as homes are built.
7. 1st Street and Brier street improvements in the Vineyard Estates subdivision, curb on east side of Alder Street (next to Vineyard Estates subdivision), curb on east side of Dogwood from 5th to 1st, curb on west side of Dogwood from 5th to a point about 100 feet north of the 1st Street intersection, sidewalk on the east side of Dogwood from 5th to a point about 400 feet north of 5th Street. Infill sidewalks are being installed as homes are built.
8. Curb and sidewalk installed on the north side of 1st Street between Dogwood and Carmel Circle (SCA grant).
9. Oliver Court completed for new subdivision.



10. Namitz Court completed for new subdivision. Pedestrian walkway connection between Namitz and Oliver.
11. Sidewalk on both sides of 1st Street near OR 99W intersection. New curb and sidewalk along the east side of OR 99W adjacent to new gas station (2nd Street to north city limits).
12. New sidewalk and curb on the north side of 7th Street starting about 100 feet east of Carmen Heights intersection to about 200 feet east of Carmen Heights intersection. Alder Street widened to 25 feet with 5-foot-wide section of the road striped and marked for pedestrian use on the west side between 7th and Upland.

These projects will be considered in the transportation analysis as part of the existing conditions and will be reflected as part of the existing local street system in the updated TSP.

#### Traffic Studies

Important traffic studies in Dundee consist of those prepared for the Riverside Master Plan. Two technical memoranda prepared by Kittelson & Associates describe the existing and future background transportation conditions for the Riverside Master Plan area and the transportation impacts of the proposed development concept for the area.<sup>34</sup>

Analysis done for the first memorandum found that access to OR 99W from the master plan area is currently restricted and long delays can occur. Completion of the Newberg-Dundee Bypass will substantially reduce OR 99W traffic volumes and improve operations at study intersections in the master plan area to acceptable levels. However, construction of the currently funded Phase 1 is likely to have limited impacts on current traffic levels, and improvements will be needed on OR 99W to maintain acceptable operations within the 20-year horizon as the bypass is being constructed. The existing TSP recommends traffic signals to be installed at identified intersections on OR 99W to serve both the hillside part of Dundee as well as the master plan area.

Even though the analysis found that study intersections will operate at acceptable levels after construction of the bypass, potential transportation demand reduction measures were recommended for the master plan area in order to balance land use and transportation needs. These measures could include land use strategies such as allowing for a mix and concentration of uses, transit services, improved and complete bicycle and pedestrian facilities, and a transportation demand management (TDM) program.

The second memorandum recommends a hierarchy of streets, with street standards modified from the adopted TSP standards, to facilitate local and regional trips. The recommendations include improvements needed on the adjacent street system to bring it up to standard, in recognition of the additional traffic that the master plan area will generate. Table 3 shows

---

<sup>34</sup> Respectively, these are memoranda dated August 13, 2010 and November 17, 2010.

planning level cost estimates for the system improvements recommended to mitigate impacts from implementation of the Riverside Master Plan.

**Table 3: Planning Level Cost Estimates for Recommended Transportation System Improvements**

Alternative/Cost Element	Estimated Cost(2010 \$) <sup>1</sup>	Cost Attributable To
North-south collector on riverside of Bypass	\$2,935,000	Developer
Edwards Road Improvements: 5 <sup>th</sup> to Parks	\$ 380,000	City/Developer
5 <sup>th</sup> Street railroad gates, coordinated with OR 99W traffic signal, including road improvements and westbound right turn lane at 99W/5 <sup>th</sup> intersection <sup>4</sup>	\$400,000	Developer/City/ODOT
Parks Road Improvements: Edwards to OR 99W	\$ 830,000	Developer/City/County/ODOT
Parks Road traffic signal at OR 99W	\$340,000	Developer/City/ODOT
Parks Road railroad gates, coordinated with OR 99W traffic signal, including road improvements <sup>4</sup>	\$400,000	Developer/City
Fulquartz Landing Improvements: So. of Parks	\$ 930,000	County/Developer/ODOT
5 <sup>th</sup> -to-8 <sup>th</sup> Extension road improvements (excluding structure over bypass)	\$2,595,000	Developer
5 <sup>th</sup> -to-8 <sup>th</sup> Extension road overcrossing structure (including approaches down to grade)	\$6,000,000 - \$10,000,000 <sup>3</sup>	ODOT
Green Seam Trails (18,870 linear feet of 10' asphalt trail)	\$1,810,000	Developer
Multi-use Path (under Bypass from 12 <sup>th</sup> to N-S Collector)	\$10,000	ODOT/City
Nature Trails (9,552 linear feet of 8' gravel/wood chip surface)	\$430,000	Developer/Chehalem Parks
<b>TOTAL</b>	<b>\$17,060,000- \$21,060,000</b>	

Notes: 1. Engineering and contingencies included at 20% of construction cost for surface streets and 40% for structures.

2. Based on ODOT NDTIP Bypass EIS cost estimate. *[Note: Reference in table is not included in original table.]*

3. Based on a shorter bridge (about 20% shorter) in this alternative, the ODOT-estimated cost in the NDTIP Bypass EIS for an 8<sup>th</sup> Street overcrossing was adjusted downward. Estimates assume 5% grade on bridge approaches – approximately \$370,000 would be saved by increasing approach grade (reducing length of ramp) to 10%.

4. A “Diagnostic Investigation,” conducted in coordination with ODOT Rail, ODOT Highway, City, and rail providers, should be conducted in which these entities will establish the threshold for construction of rail improvements.

**Existing Transportation Funding Mechanisms**

The City has adopted a local, 2 cents per gallon gas tax for transportation improvements. The major source of funding for new streets and street improvements related to growth will be developer contributions. The TSP update will explore a variety of mechanisms for funding recommended transportation system improvements and will indicate recommended methods specific to the needed improvement.

# MEMORANDUM #3

**DATE:** February 10, 2012

**TO:** Dundee TSP Update Project Management Team

**FROM:** Carl Springer, P.E., DKS Associates  
Ray Delahanty, DKS Associates  
Darci Rudzinski, AICP, Angelo Planning Group  
Shayna Rehberg, AICP, Angelo Planning Group

**SUBJECT: Dundee Transportation System Plan Update  
Goals, Objectives, and Evaluation Criteria**

---

The purpose of this memorandum is to present draft goals, objectives, and evaluation criteria for the City of Dundee Transportation System Plan (TSP) update, providing a basis for discussion as the community moves through the TSP update process. Goals and objectives presented here are expected to evolve, and will not become fixed until adopted by the city council.

The goals are broad, high-level statements describing the community's intentions for the future. Each goal is developed around a topic area, and while a goal may never be completely attainable, it is used as a point toward which to strive. The objectives described under each goal are statements providing a specific course of action that moves the community toward that particular goal. Each new capital improvement project, land use application, or implementation measure must be consistent with the objectives.

This memorandum is divided into two sections. The first section reviews goals and objectives that guided the development of the 2003 TSP, highlights areas for review by project participants, and suggests evaluation criteria. The second section presents adopted planning goals, objectives, and policies from the City of Dundee Comprehensive Plan and highlights areas that should be reviewed by project participants and possibly revised prior to inclusion as the updated transportation goals and objectives.

The goals and objectives will guide the development of the transportation system plan, while the evaluation criteria will be used to assess and prioritize future transportation programs and improvements against the goals and objectives. Once adopted, the goals and objectives, as well as the project list, will become part of the City of Dundee's Comprehensive Plan.

## Existing TSP Goals and Policies

The existing goals and objectives from the Dundee TSP are provided below. Changes and additions are suggested in italics. Objectives that are already addressed under other goals are flagged as duplicates. Removal of these duplicate objectives can be considered, but is not necessary.

### Goal 1: System Capacity and Mobility

Provide and maintain a transportation system that serves the travel needs of all Dundee residents, businesses, and visitors, and minimizes the adverse impact of through travelers on Dundee.

#### Goal 1 Objectives

1. Improve system connectivity
2. Conduct facility management
3. Minimize congestion
4. Provide and support travel choices (*Duplicated under Goal 4*)

#### Suggested Goal 1 Evaluation Criteria

- *Increases system connectivity*
- *Improves roadway operations*

### Goal 2: Livability

Provide and maintain a transportation system that fosters a pleasant, small city and preserves and enhances existing neighborhoods and businesses.

#### Goal 2 Objectives

1. Improve mobility (*Duplicated under Goal 1*)
2. Minimize disruptions to neighborhoods and businesses
3. Enhance economic vitality (*Duplicated under Goal 9*)
4. Manage transportation facilities (*Duplicated under Objective 1.2*)
5. Minimize energy, social, environmental, and economic impacts (*Duplicated under Goal 6*)
6. Improve pedestrian facilities (*Duplicated under Goal 4*)
7. Improve bicycle facilities (*Duplicated under Goal 4*)
8. *Design streets to support a wide range of users and enhance quality of life and sense of place*
9. *Incorporate sidewalk and vegetation improvements*
10. *Incorporate street furnishings that reflect the city's unique character*

#### Suggested Goal 2 Evaluation Criteria

- *Improves street aesthetics*
- *Reflects unique city character*
- *Provides street classifications that are consistent with residents' travel needs*

### Goal 3: Coordination

Develop and maintain a transportation system that is consistent with and supports the goals, objectives, and visions of the Dundee community, participating and affected agencies, the county, and the state.

#### Goal 3 Objectives

1. Support adopted local land use plans
2. Provide for appropriate interjurisdictional communication
3. Achieve consistency with State and County plans
4. Practice public outreach

#### Suggested Goal 3 Evaluation Criteria

- *Compatible with regulatory documents*
- *Demonstrated public and/or decision-maker support*

### Goal 4: Travel Options

Develop and maintain a transportation system that encourages, supports, and incorporates a variety of multi-modal travel options.

#### Goal 4 Objectives

1. Improve bicycle facilities
2. Improve pedestrian facilities
3. Support transit and rail system development (*This process should clarify whether this refers to passenger rail or freight; if freight then a separate objective under Goal 9 is appropriate*)
4. Improve truck access and circulation (*May be more appropriate under Goal 9*)
5. *Encourage walking and bicycling for trips within the city*

#### Suggested Goal 4 Evaluation Criteria

- *Improves pedestrian/bicycle access to key destinations*
- *Improves pedestrian comfort*
- *Improves freight access/connectivity (May be more appropriate under Goal 9)*
- *Increases alternatives to single-occupant vehicle travel*
- *Increases attractiveness of walking and bicycling*

### Goal 5: Accessibility

Provide and maintain a well-connected transportation system that serves the needs of all members of the community and ensures adequate and efficient accessibility for all acknowledged land uses, and available modes of travel.

#### Goal 5 Objectives

1. Link recreation and other local destinations
2. Comply with American Disabilities Act requirements



3. Support local land use plans
4. Manage transportation facilities (*Duplicated under Objective 1.2*)
5. Provide and support travel choices (*Duplicated under Goal 4*)
6. *Provide adequate access to properties*

#### **Suggested Goal 5 Evaluation Criteria**

- *Improves connections to recreation and other local destinations*
- *Compatible with ADA requirements*
- *Supportive of local land use plans*
- *Maintains or improves access to properties*

### **Goal 6: Environment**

Provide and maintain a transportation system that preserves, protects, and supports the social, natural, and cultural environment of the Dundee community.

#### **Goal 6 Objectives**

1. Minimize energy, social, environmental, and economic impacts
2. *Prioritize environmentally sustainable transportation improvements*

#### **Suggested Goal 6 Evaluation Criteria**

- *Protects environmentally sensitive areas*
- *Reduces vehicle miles traveled*
- *Minimizes impacts to historic structures*
- *Promotes opportunities for positive social interaction*

### **Goal 7: Timely Provision and Funding of Transportation Facilities and Services**

Develop reasonable and effective funding and financing strategies and priorities to ensure that the future transportation facilities and services called for in the TSP are provided to support community development and acceptable transportation operations and safety.

#### **Goal 7 Objectives**

1. Identify full range of potential funding sources
2. Match fund sources to system improvement and maintenance needs
3. Prioritize improvement needs
4. Phase needed improvements
5. Acquire and preserve right-of-way needed for system improvements
6. Require mitigation of public and private development transportation impacts

#### **Suggested Goal 7 Evaluation Criteria**

- *Eligible for a variety of funding opportunities*
- *Addresses a transportation need or deficiency identified in the TSP*

## Goal 8: Safety

Develop and maintain a transportation system that protects the health and safety of transportation system users.

### Goal 8 Objectives

1. Reduce vehicle crashes
2. Reduce transportation-related injuries
3. Improve pedestrian facilities (*Duplicated under Goal 4*)
4. Improve bicycle facilities (*Duplicated under Goal 4*)
5. *Reduces pedestrian/motor vehicle conflicts (Replaces Objective 3)*
6. *Reduces bicycle/motor vehicle conflicts (Replaces Objective 4)*

### Suggested Goal 8 Evaluation Criteria

- *Improves intersection/bicycle/pedestrian/railroad crossing safety*

## Goal 9: Economic Development

Provide and maintain a transportation system that supports the economic vitality of the Dundee community.

### Goal 9 Objectives

1. Accommodate freight movement to support local businesses
2. Provide for convenient parking and access to local businesses and other key destinations
3. Provide economic development opportunities
4. Provide transportation choices that support employers and employees
5. Minimize transportation conflicts between neighborhoods and businesses
6. Improve bicycle and pedestrian circulation

### Suggested Goal 9 Evaluation Criteria

- *Minimizes negative impacts to existing land uses*
- *Increases attractiveness to investment and development*
- *Minimize impacts on on-street parking*
- *Provides access to commercial and “destination” (recreation, wineries, tourism, etc.) uses*

## Comprehensive Plan Goals, Objectives, and Policies

The City’s Comprehensive Plan (1977) features a more current set of goals, objectives, and policies that direct development of the City’s transportation system (pp. 72-76, 1977 Comprehensive Plan). This includes amendments to transportation policies made in 2003 and 2004 (pp. 74-76, 1977 Comprehensive Plan). More recent policy amendments

pertaining to the Newberg-Dundee Bypass (Policies 7 and 10-14, adopted in Ordinance 502-2011) have not yet been incorporated into the Comprehensive Plan document.

The proposed goals, objectives, and policies included in this section are the City's adopted transportation system goals, objectives, and policies, as found in the Comprehensive Plan and in Ordinance 502-2011. While all policy language will be reviewed and potentially updated as part of this TSP update, selected policies have been identified that will likely need to be updated or modified. Notes in italics provide direction and/or suggest specific amendments. In most cases the direction is to review the policy in light of the findings of the TSP update process or to update language to be consistent with recent planning efforts, such as the Riverside District Master Plan.

In addition to the suggestions following select policies, the following global issues will need to be discussed and resolved by the Project Advisory Committee (PAC):

- The structure of the Goals, Objectives, and Policies section of the TSP and consistency with the Comprehensive Plan.
- Review of Newberg-Dundee Bypass policies in light of recent project work on the Bypass.
- Possible new policies that support concepts from the 2006 Main Street Refinement Plan, such as planning for a transportation system that would support planned land uses/mixed land uses, a pedestrian-oriented streetscape, "green corridors" for pedestrians and bicyclists, etc.
- Integrating policies that support and are consistent with the adopted Riverside District. The PAC may decide to integrate Riverside District Master Plan goals and policies into the TSP directly, or handle it as an overlay district.

Feedback from the PAC will inform changes and additions to the City's existing transportation policy language, which will be included as recommendations in the Draft TSP.

## **GOAL**

To provide and encourage a safe, convenient, aesthetic and economical transportation system, addressing the needs of all citizens within the community.

## **OBJECTIVES**

- A. The development of a well-connected street network that is safe, accessible and efficient for motorists, pedestrians, bicyclists and the transportation disadvantaged.
- B. Preserve the aesthetic quality of the community.

C. The construction of a safe, continuous and direct network of streets, accessways, and other improvements, including bikeways, sidewalks, and safe street crossings to promote safe and convenient bicycle and pedestrian circulation within Dundee. *[Consider ODOT standards and policies for 99W.]*

D. Develop policies for the location and improvement of arterials, collectors, local streets and sidewalks. *[These policies to be developed in tandem with updated street standards, and should consider ODOT standards for 99W as well.]*

E. Improve the transportation links within the region as well as other regions of the state, while encouraging alternative transportation mode for commuters.

## **POLICIES**

### **A. General Transportation Network**

1. The designated arterial and collector streets of the street network will be used to assist in prioritizing street development and maintenance.
2. The City of Dundee shall protect the function of existing and planned roadways as identified in the Transportation System Plan. This policy recognizes the proposed new street locations are conceptual in nature and the actual dedication and installation of improvements shall comply with applicable regulations, including environmental provisions. *[This policy to be reviewed during TSP update; language should support implementation of a transportation impact analysis development requirement.]*
3. All development proposals, plan amendments, or zone changes shall conform with the adopted Transportation System Plan.
4. The City of Dundee shall include a consideration of their impact on existing or planned transportation facilities in all land use decisions. *[This policy to be reviewed during TSP update; intent is not currently clear and language should support implementation of a transportation impact analysis and mitigation requirements.]*
5. Transportation facility siting and design shall be done in a manner that will minimize adverse effects on the existing land uses and natural features.
6. The City of Dundee shall protect the function of existing or planned roadways or roadway corridors through the application of appropriate land use regulations, exactions, voluntary dedication, or setbacks. *[This policy to be reviewed during TSP update; it is similar to #2 above and may be reworded/combined.]*
7. New direct access to Highway 99W shall be granted only after consideration is given to Oregon Department of Transportation access management standards, land use and traffic patterns in the area of development, and not just at the specific site. Common driveways and other access management techniques shall be encouraged to coordinate traffic and land use

patterns and these shall be implemented wherever feasible. *[Recommend all references to "Oregon Department of Transportation" be changed to "ODOT." Recommend rewording to emphasize minimizing access points on 99W.]*

8. The City shall coordinate development and revisions of its transportation systems plan with the Oregon Department of Transportation and Yamhill County. Improvements listed in ODOT's Statewide Transportation Improvement Program that affect Dundee shall be consistent with the City's Transportation System Plan and Comprehensive Plan.

9. Off-street parking shall be provided by all land uses to improve traffic flow, promote safety, and lessen sight obstruction along the streets. *[Refine this policy or create a new policy to indicate that the preferred location for commercial parking is to the side or behind buildings.]*

10. The City shall develop a Capital Improvement Program to identify and prioritize transportation projects.

11. All City streets shall operate at a Level of Service standard "D" or better during the 20 year planning period. When the LOS drops to "E," actions will be initiated to return the street to LOS "D". *[This policy to be reviewed during TSP update.]*

12. The City of Dundee shall work with Oregon Department of Transportation on a continual basis to have a traffic signal installed at the Parks Road/Highway 99W and 10<sup>th</sup> Street/Highway 99W intersections as soon as possible. *[This policy to be reviewed during TSP update, and consider need for State Traffic Engineer approval.]*

13. Through the refinement plan process, the City of Dundee will investigate the potential of developing a unique streetscape plan for the community's downtown, including the potential for establishing a Special Transportation Area consistent with ODOT regulations. *[This policy to be revised in light of the Downtown Refinement Plan process and the outcome of the TSP process.]*

## **B. Newberg-Dundee Bypass**

1. The City shall coordinate with the Oregon Department of Transportation, Yamhill County and other affected agencies regarding the location and construction of the Newberg-Dundee Bypass.

2. The City shall encourage the selection of a bypass alternative that ensures sufficient traffic is diverted from Highway 99W through Dundee to allow the remaining traffic to be served by two travel lanes within the Transportation Plan's planning horizon. *[This policy to be reviewed during TSP update.]*

3. The City shall encourage the new by-pass design to provide adequate public access - including pedestrian, bicycle, vehicle and recreational - to the Willamette River. *[All references to the Bypass will be made consistent.]*

4. The City shall encourage the new bypass design to incorporate adequate buffering and physical separation between the new highway, and, public access to the Willamette River and existing residential neighborhoods.
5. Improvements for street connectivity within the City, including alternative linkages to adjacent communities, shall not occur until such time the bypass is in operation. *[Update policy to be consistent with Bypass policies and interim measures proposed through the TSP update process.]*
6. The land use decisions regarding the location of the proposed Newberg-Dundee Bypass shall be made through a subsequent amendment to the Dundee TSP. As part of this process, the City recognizes Newberg and Yamhill County will need to amend their TSPs to authorize a bypass corridor, and, Yamhill County must take an exception to Statewide Planning Goal 12 to authorize a new transportation facility in rural lands. *[Revise as a City policy statement and update to recognize that a potential UGB amendment or Goal 3 exception may be required for a Bypass overcrossing in the Riverside District.]*
7. The City actively supports the development of the Newberg-Dundee Bypass in the southern location corridor described as Alternative 3J (Modified) in the Tier 1 Location Environmental Impact Statement. The City prefers a below-grade roadway, however the City recognizes that ODOT has selected an at-grade roadway with 6-8 foot berms as the preferred alternative in the Tier 2 Draft Environmental Impact Statement (DEIS) process. *[Update to be consistent with Tier 2 DEIS and 2011 Bypass policies.]*
8. The City affirms its support for a Bypass location and design that recognizes existing Comprehensive Plan policies, including Recreation and Willamette River Greenway policies, and which includes providing public access to the Willamette River and the City's waterfront for park and recreational development.
9. The City recognizes the designation of the Bypass as a statewide expressway and freight route as defined in the Oregon Highway Plan. The City expects the Bypass and interchanges will be fully access controlled and no direct access will be allowed from private properties on the Bypass or within the Interchange Management Areas as defined by the OHP.
10. For purposes of City compliance with the Transportation Planning Rule (OAR 660-012-0060), the City will not consider or rely on the Bypass (including the proposed East Dundee Interchange) improvement that is reasonably likely to be constructed during the 20-year planning horizon until the OTP includes all or a specific phase of the Bypass in the construction section of the Statewide Transportation Improvement Program (STIP) or until ODOT agrees, in writing that all or a portion of the bypass may be considered a planned improvement. During the period before the Bypass can be considered a planned improvement, the City of Dundee will work with ODOT to pursue mutually agreed upon alternative mobility standards for Oregon 99W to comply with OAR 660-012-0060. *[Update to reflect current status of JTA Newberg-Dundee Bypass project.]*



11. An Interchange Area Management Plan (IAMP) will be developed to protect the function and capacity of the East Dundee Interchange for at least a 20 to 25-year period. The IAMP must be adopted by the Oregon Transportation Commission (OTC) before construction of the interchange, consistent with the requirements of the 1999 Oregon Highway Plan and OAR 734-051-0155(7). *[Revise as a City policy statement and identify how the City intends to participate in this planning.]*

12. Figure 6-1 of the Dundee TSP identifies three potential collector road crossings of the Bypass for illustrative purposes only. The City recognizes that one of the crossings will be constructed as part of the Bypass project to maintain connectivity between downtown Dundee and the Riverfront. The Tier 2 DEIS, Preferred Alternative, identifies an overcrossing in the vicinity of 8<sup>th</sup> Street. The City is in the process of master planning the undeveloped area between Dundee and the Willamette River. At a future date, Figure 6-1 of the Dundee shall be amended to reflect either the Tier 2 DEIS Preferred Alternative for the overcrossing or the location for the overcrossing identified in the adopted Riverfront master plan. ODOT will continue to coordinate with the City on location of the overcrossing and is flexible on the ultimate location with the UGB if it could serve all property ownerships between the Bypass and the Willamette River. *[Revise as a City policy statement. Update to acknowledge the approximate locations identified in the Riverside District Master Plan.]*

13. The City recognizes that the Oregon Highway Plan seeks to avoid UGB expansions along Statewide Highways and around interchanges unless ODOT and affected cities and counties agree to an Interchange Area Management Plan to protect interchange operation or access management for segments along the highways. (OHP Action 1B.4).

### **C. Pedestrian and Bicycle Facilities**

1. In areas of new development the City of Dundee shall investigate the existing and future opportunities for bicycle and pedestrian accessways. Existing accessways such as user trails established by school children distinguish areas of need and should be incorporated into the transportation system.
2. Bike lanes and/or sidewalks shall be included on all new arterials and collectors within the Urban Growth Boundary, as referenced by the Transportation System Plan.
3. Sidewalks shall be included on all new streets within the Urban Growth Boundary, as referenced by the Transportation System Plan.
4. Where feasible, bikeways and pedestrian accessways shall connect to local and regional travel routes.
5. Bikeways and pedestrian accessways shall be designed and constructed to minimize potential conflicts between transportation modes. Design and construction of such facilities shall follow the guidelines established by the Oregon Bicycle and Pedestrian Plan.

6. Maintenance and repair of existing bikeways and pedestrian accessways (including sidewalks) shall be given equal consideration to the maintenance and repair of motor vehicle facilities.
7. To achieve a safe, continuous and direct network of sidewalks and bikeways, one of the City's priorities is to construct these facilities on the streets depicted on the Pedestrian/Bicycle Plan Map as incorporated within the Transportation System Plan.
8. The City of Dundee shall consider the potential to establish or maintain accessways, paths, or trails prior to the vacation of any public easement or right-of-way.
9. Where possible and financially feasible, the City will upgrade existing substandard sidewalks.

#### **D. Public Transportation**

1. The City shall encourage the creation of a customer-based and oriented regionally coordinated public transit system that is efficient, effective, and founded on present and future needs.
2. Promote regional planning of public transportation services and encourage the use of innovative technology to maximize efficiency of operation, planning and administration of public transportation.
3. The City encourages the development of a daily transit shuttle service to the major activity centers in Newberg and McMinnville as well as the Portland and Salem metropolitan areas.  
*[Update to reflect existing Yamhill County Transit Area service and future review/ coordination/ updates to service.]*

#### **E. Rail and Pipeline Transportation**

1. The City shall coordinate land use planning adjacent to the Willamette and Pacific Railroad facilities in order to promote industrial development with rail access.
2. The City will work with the local rail operator, the Oregon Department of Transportation and other affected agencies or businesses to improve the at-grade railroad crossings within the community.
3. The City supports the concept of commuter rail service serving the West Valley and providing connections with the Portland metropolitan area. If passenger rail service does become a reality, the City will encourage the development of a passenger rail depot in Dundee, including necessary Development Ordinance revisions to permit construction.
4. The City supports activities that maintain adequate pipeline operations such as natural gas service into, within and through Dundee.

**DATE:** April 24, 2012

**TO:** Dundee TSP Update Project Management Team

**FROM:** Carl Springer, P.E., DKS Associates  
Ray Delahanty, DKS Associates

**SUBJECT: Dundee Transportation System Plan Update  
Existing Conditions**

---

The purpose of this memorandum is to present existing transportation conditions for the City of Dundee. Questions addressed in this document include:

- What makes Dundee different?
- Where do people want to go?
- How do people get there?
- What transportation infrastructure is available?
- How is system performance measured?
- What conditions do transportation system users face?

### **What Makes Dundee Different?**

The City of Dundee is located in the Willamette Valley, in the heart of Oregon wine country. The setting provides a small town feel, with working vineyards nestled up against established neighborhoods, and all city destinations within about a half-mile of the city center. The topography is characterized by the Dundee Hills rising to the northwest, and the city sloping down toward the Willamette River to the southeast. The setting has proved attractive to new residents, with the population growing from 2,598 in the 2000 census to 3,162 in 2010.



**Dundee neighborhoods and working vineyards exist side by side**

Dundee's location (see Figure 1) also makes it an attractive for visitors, as the city itself is home to world-class wineries, and county roads that converge on the city provide access to several other wineries and popular nearby vineyards. Also, travelers from the Portland metropolitan region on their way to destinations like the Evergreen

Aviation and Space Museum in McMinnville, recreational activities in the Grand Ronde area, and the Oregon coast often pass through Dundee.

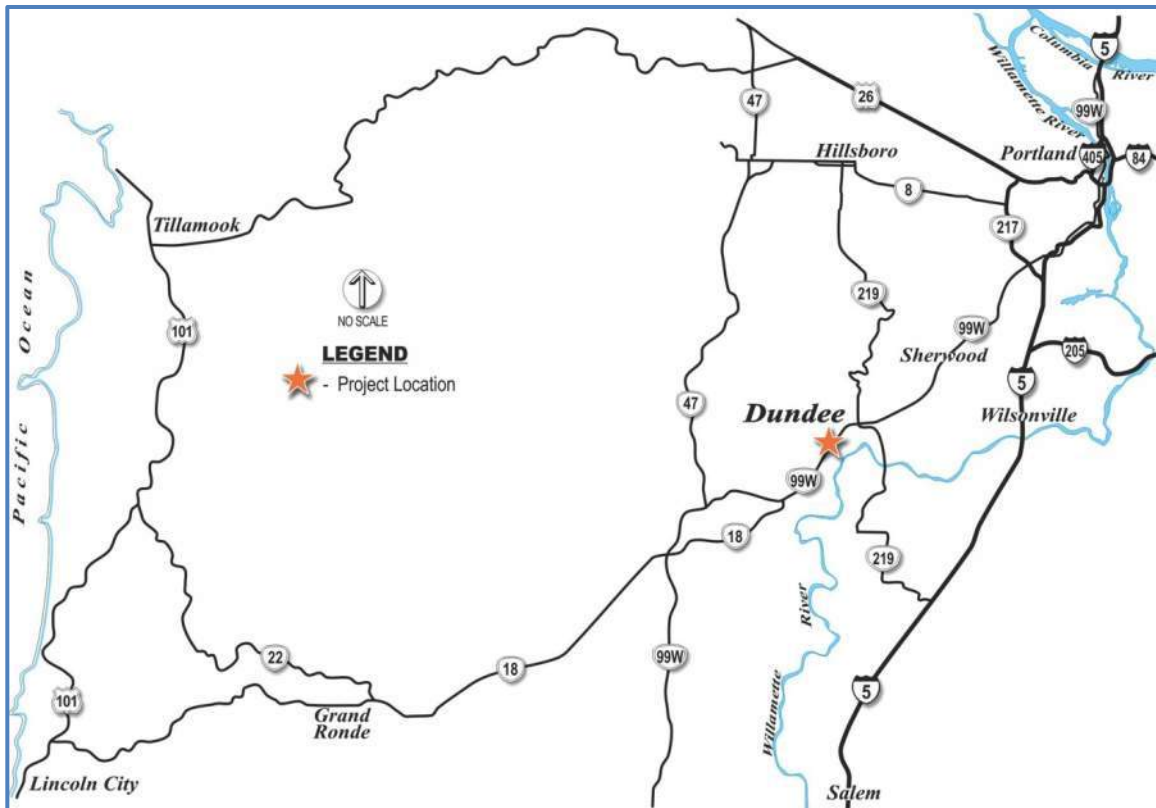

**Figure 1: Dundee Vicinity Map**

The city was incorporated in 1895, and its location on key freight corridors has always been part of its identity. Early on, it was a key shipping hub along the Willamette River, and later it gained interurban rail service when the Red Electric line opened between Portland and Eugene. The automobile age saw the opening of the Capitol Highway through the center of Dundee, which in 1930 was assigned the US Route number 99W. The role of 99W as a key route between the Portland region, the Oregon coast, and attractions is as important to the character of Dundee today as it was when the highway first opened.

The City of Dundee continues to make important progress towards balancing its small-town feel with its role on a key transportation corridor. A master plan for the currently undeveloped Riverside District envisions a mix of residential, commercial, tourism, and open space stretching toward the Willamette. Also,



the City has worked closely with state and regional partners to plan and design a 99W bypass route that will alleviate some of the traffic issues on Dundee’s main street. These planning efforts define key future transportation issues that the City seeks to address in this Transportation System Plan (TSP) update. Figure 2, below, shows the study area for the TSP, including major roadways and intersections that were reviewed for motor vehicle, pedestrian, and freight activity.

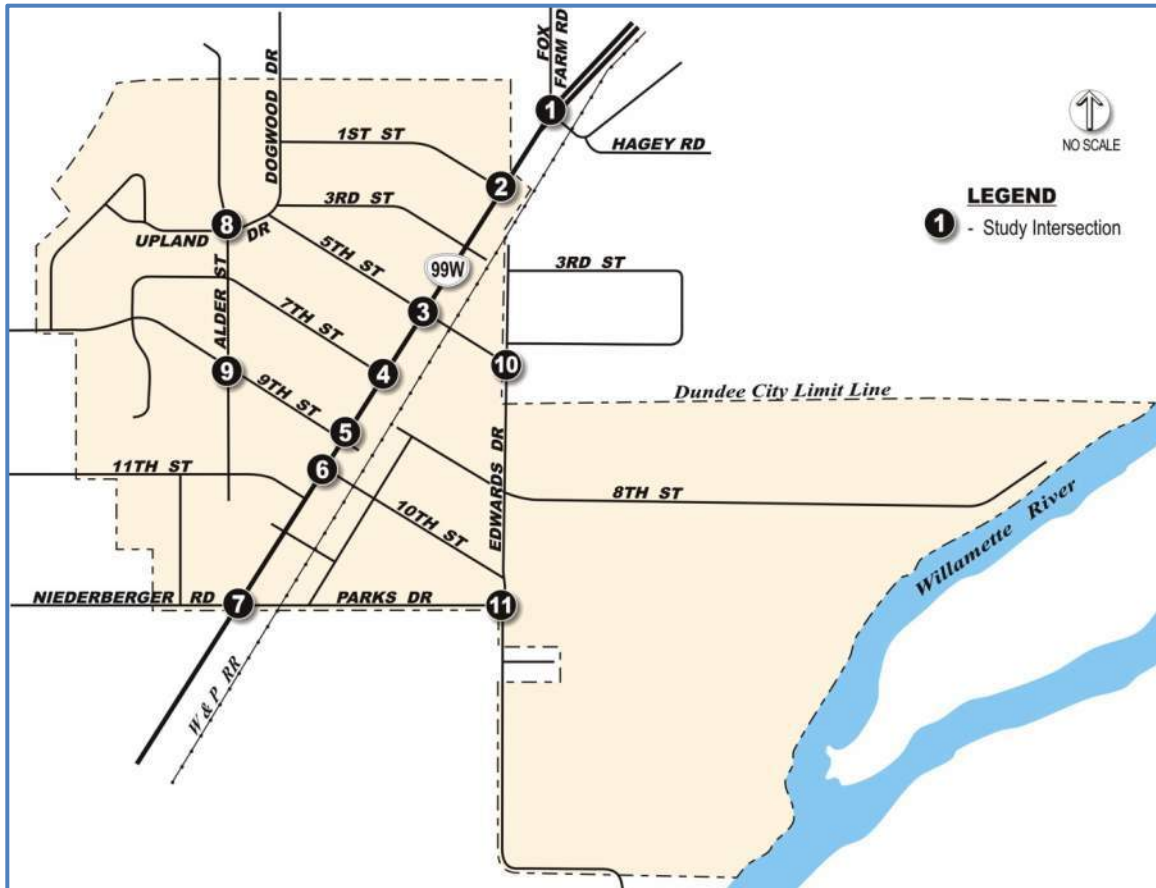

Figure 2: Dundee Roadways and Study Intersections

## Where Do People Want to Go?

Planning for a transportation system that meets the City's needs requires an understanding of key travel destinations throughout Dundee – locations that create demand for travel because they are where people go to work, to school, or to take care of other daily needs. These key destinations can be thought of as activity generators, or trip attractors.

Activity generators may be destinations that residents use for their daily needs, or they may be attractions that draw travelers from around the region. The most common categories of activity generators in Dundee include:

- Recreational (e.g., parks, trails)
- Schools (e.g., Dundee Elementary)
- Places of employment (e.g. business and industrial locations)
- Shopping (e.g., grocery stores, restaurants)
- Public transportation (e.g., bus stops)

All of these activity generator types represent important starting and ending points for travel in Dundee, and they provide a basis for assessing important travel routes. Figure 3 shows the general location of some of the City's key activity generators.



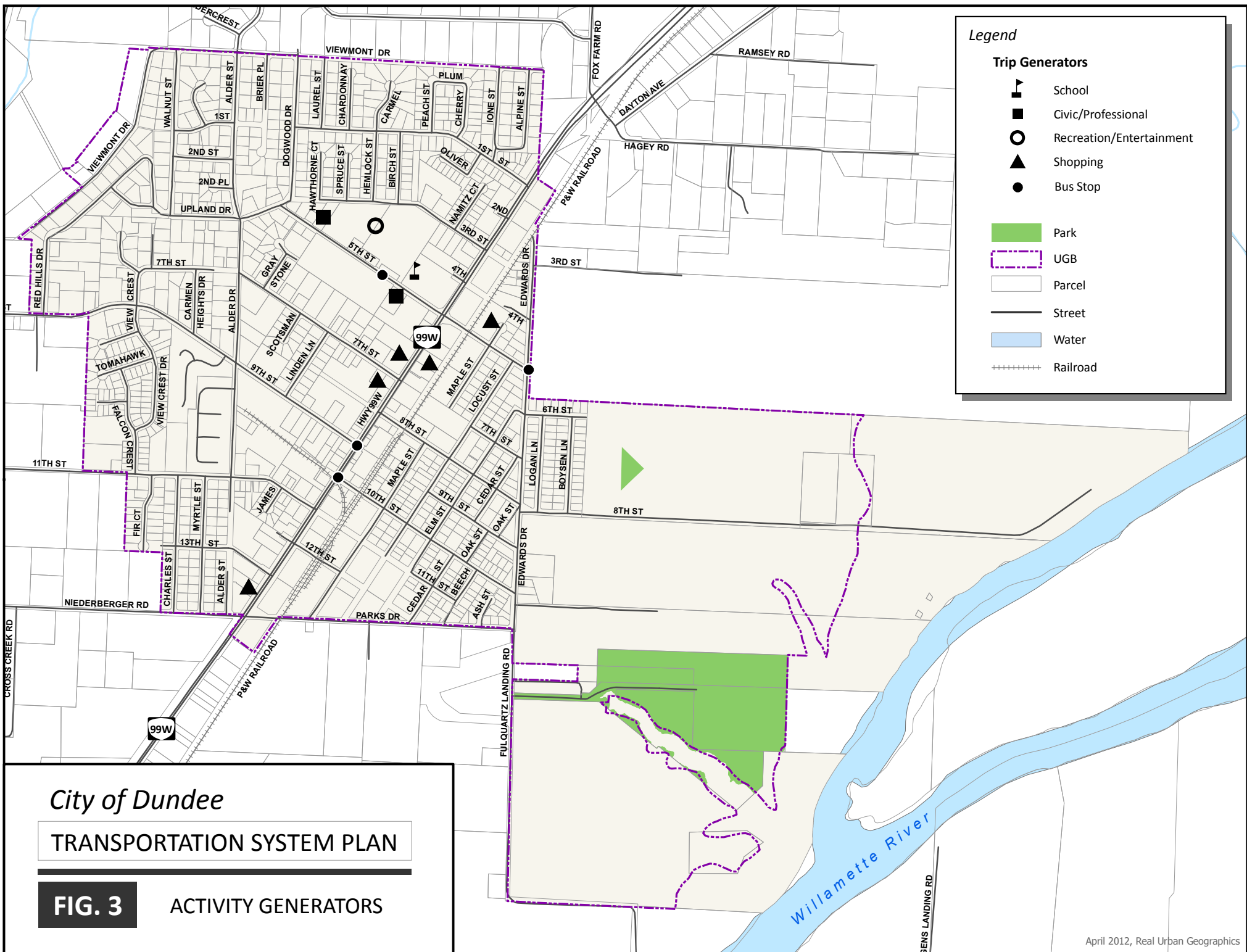

## How Do People Get There?

Planning for an effective transportation system also means understanding how Dundee residents choose to travel to and from destinations, whether by foot, bicycle, public transportation, motor vehicle, or other mode. Understanding **mode choice** includes assessing existing travel patterns and activity levels, and looking at the underlying factors particular to Dundee that inform mode choice.

### The Commute to Work

Travel occurs for many reasons, including school, shopping, and recreation. The trip type that people most often associate with traffic problems, though, is their work trip, which often occurs in peak traffic conditions. 80% of working Dundee residents commute to work by driving alone (single occupant motor vehicle, or SOV), and 10% carpool to work. Public transportation (2%), walking (2%), and bicycling (1%) are not common modes for the journey to work, and 6% work at home.

Table 1 compares Dundee residents' mode choice for commute to Yamhill County and to Oregon statewide. The proportion of Dundee residents driving alone to work is higher than that of all Oregon residents, and the percentage commuting by every other mode (transit, walking, biking) is lower in Dundee than it is statewide. The comparisons are similar between Dundee and Yamhill County as a whole, with the proportion of Dundee residents driving alone to work exceeding that of all County residents. However, a slightly higher proportion of Dundee residents commute by transit than is seen countywide.

**Table 1: Percent of Commuters Using Modes**

Transportation Mode	Dundee	Yamhill Co.	Oregon
Motor Vehicle – Single Occupant	80%	75%	72%
Motor vehicle - Carpool	10%	12%	11%
Walked	2%	5%	4%
Biked/Other	1%	2%	3%
Public Transportation	2%	1%	4%
Worked from Home	6%	5%	6%

Source: 2006-2010 American Community Survey

While data on commute mode choice is important in understanding major travel patterns, it is important not to confuse this with overall levels of activity for different travel modes. Work trips for Dundee residents cover long distances in many cases, while trips to and from other activity generators like schools, recreation, and shopping may be much shorter. Non-motor vehicle modes tend to be more likely for these non-work trips, although travel into neighboring Newberg is necessary for certain types of school and shopping trips.

## Existing Activity Levels

Pedestrian, bicycle, and motor vehicle activity at intersections throughout Dundee was reviewed for the p.m. peak period (3:00 p.m. to 6:00 p.m.) on a typical weekday in February.<sup>1</sup> In summer months, activity levels are generally higher due to an increase in the number of visitors and vacationers traveling through. Also, weekend activity levels were not measured, but because of the higher level of shopping and recreational travel on weekends, pedestrian and bicycle activity would be expected to be higher.

## Pedestrian Volumes

Of all the intersections reviewed, two locations on Highway 99W had notable levels of pedestrian crossing activity. The highest pedestrian volume was on the crosswalk at 10<sup>th</sup> Street, near the location of the southbound transit stop for the commuter bus from the Portland metro area. The second highest volume was at Dundee's only signalized intersection on 99W, at 5<sup>th</sup> Street, where Dundee Elementary School is located.

Pedestrian activity at all study intersections for the one-hour p.m. peak period is shown in Figure 4. Note that counts were taken in February, which due to weather is likely to have lower pedestrian activity than summer months. In busy tourism months, the crosswalk at 7<sup>th</sup> Street, which connects restaurants, shops, and wineries, may be significantly busier than other crosswalks.



After-school crossing at 5<sup>th</sup> Street and 99W

## Bicycle Volumes

During the p.m. peak period on a February weekday, bicycle volumes are low through Dundee. Bicycle use tends to vary seasonally, as warmer, dryer weather and longer daylight hours make it a more attractive travel mode. Bicycle activity at all study intersections for the one-hour p.m. peak period is shown in Figure 4.

## Motor Vehicle Volumes

Review of traffic count data showed that the evening peak period for roadways in Dundee occurs between 4:45 p.m. and 5:45 p.m. Motor vehicle activity varies depending on time of year, however, as the level of tourism increases during summer months. Warmer weather brings an influx of visitors to Dundee and other Yamhill County destinations, and it also brings an increase in vacation travel to the Oregon Coast along 99W. Because of these important seasonal

<sup>1</sup> Based on counts conducted February 7, 2012 and February 2, 2011

variations, traffic count data was adjusted to represent two separate conditions: p.m. peak hour traffic conditions during (1) the peak month weekday, and (2) the average weekday.

Traffic count data was collected in Dundee in the month of February, and required adjustment in order to represent average weekday and peak seasonal conditions using methodology from the Oregon Department of Transportation (ODOT) Analysis Procedures Manual.<sup>2</sup> Because seasonal travel patterns on the street system off of 99W are expected to reflect a commuter trend rather than a coastal destination trend, separate adjustment factors were used. The seasonal and average adjustment factors for 99W are, respectively, 1.14 and 1.03, and the factors for all non-99W intersections are 1.11 and 1.05. The final p.m. peak seasonal and average weekday traffic volumes developed for the study intersections are displayed in Figure 5.

Generally, volumes in the p.m. peak hour on 99W are higher at the north end of Dundee, between Fox Farm Road and 5<sup>th</sup> Street, with around 15% more daily traffic than locations south of 5<sup>th</sup> Street. The chart on the right shows how northbound and southbound volumes on 99W vary during the day between 5<sup>th</sup> and 7<sup>th</sup> Streets, a

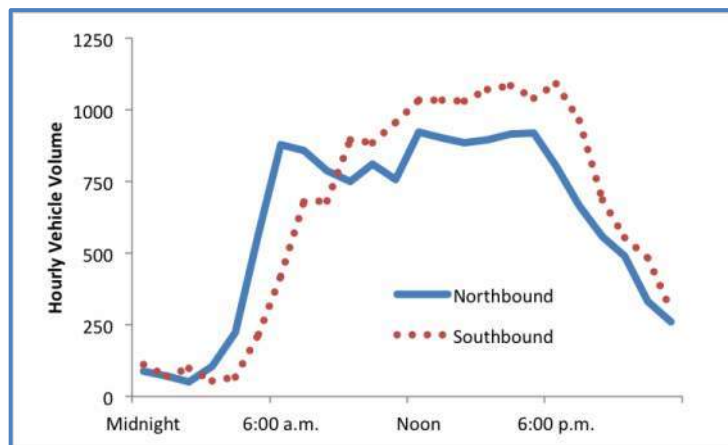

Hourly Vehicle Volumes on 99W North of 7<sup>th</sup> Street

segment which currently experiences an average daily traffic (ADT) level of about 30,000 vehicles<sup>3</sup>. The northbound direction shows heavier morning activity, suggesting commuter traffic towards Newberg and the Portland metro area, while the southbound direction carries the most traffic during the afternoon and the p.m. peak hour, suggesting returning commuter traffic.

<sup>2</sup> See appendix for more information on seasonal factoring.

<sup>3</sup> 24-hour traffic count data on Highway 99W collected at 6<sup>th</sup> Street on July 22, 2011.



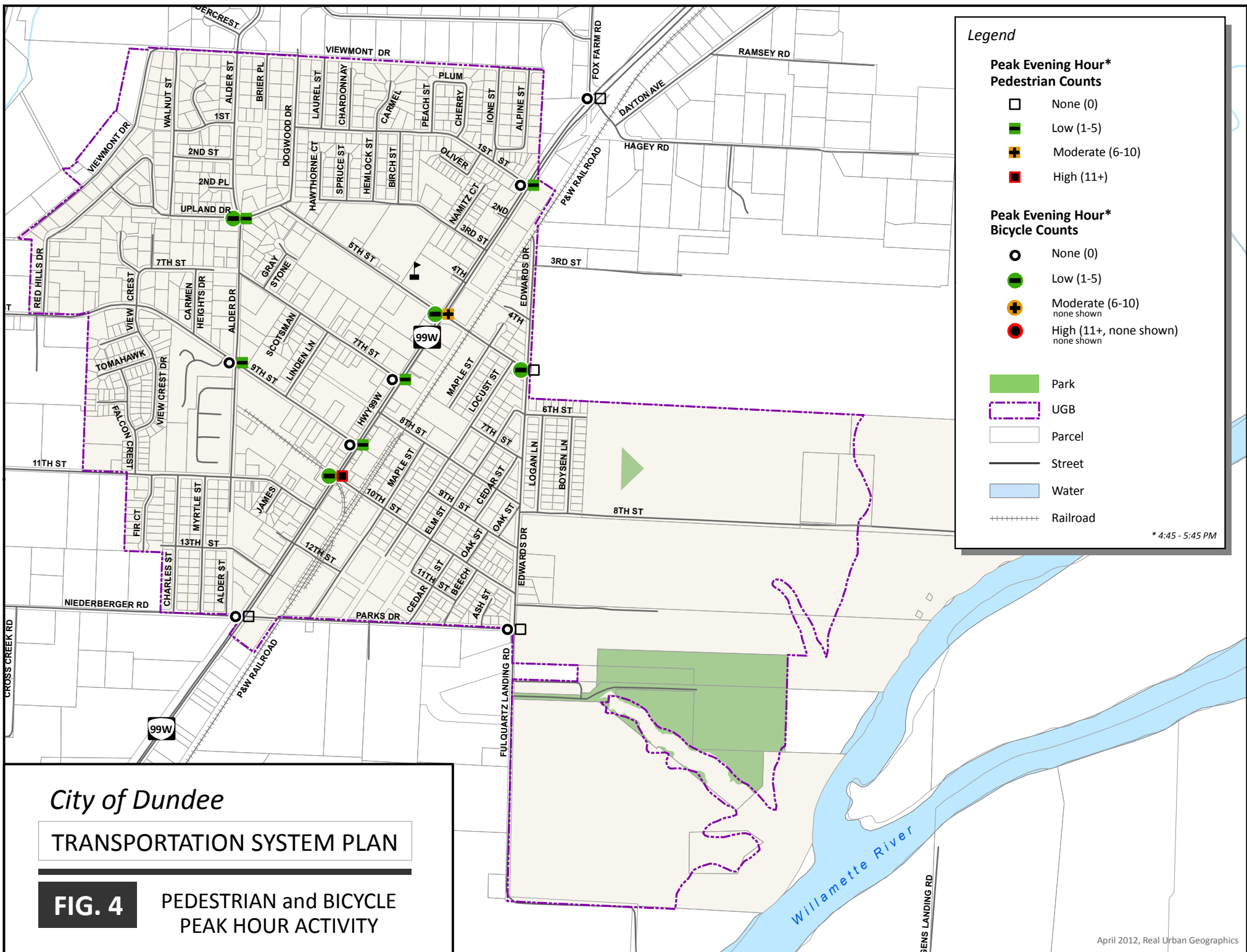



NO SCALE

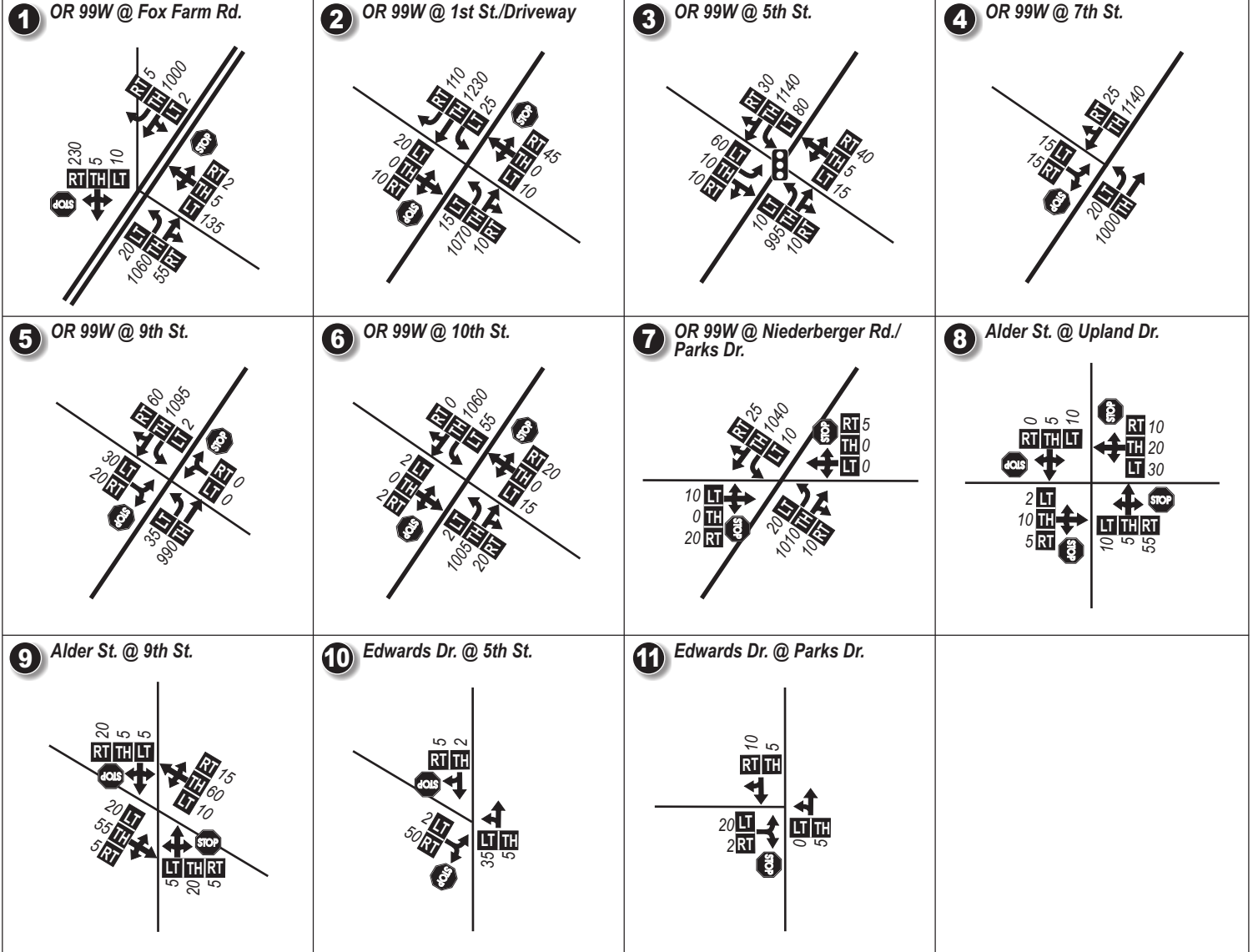
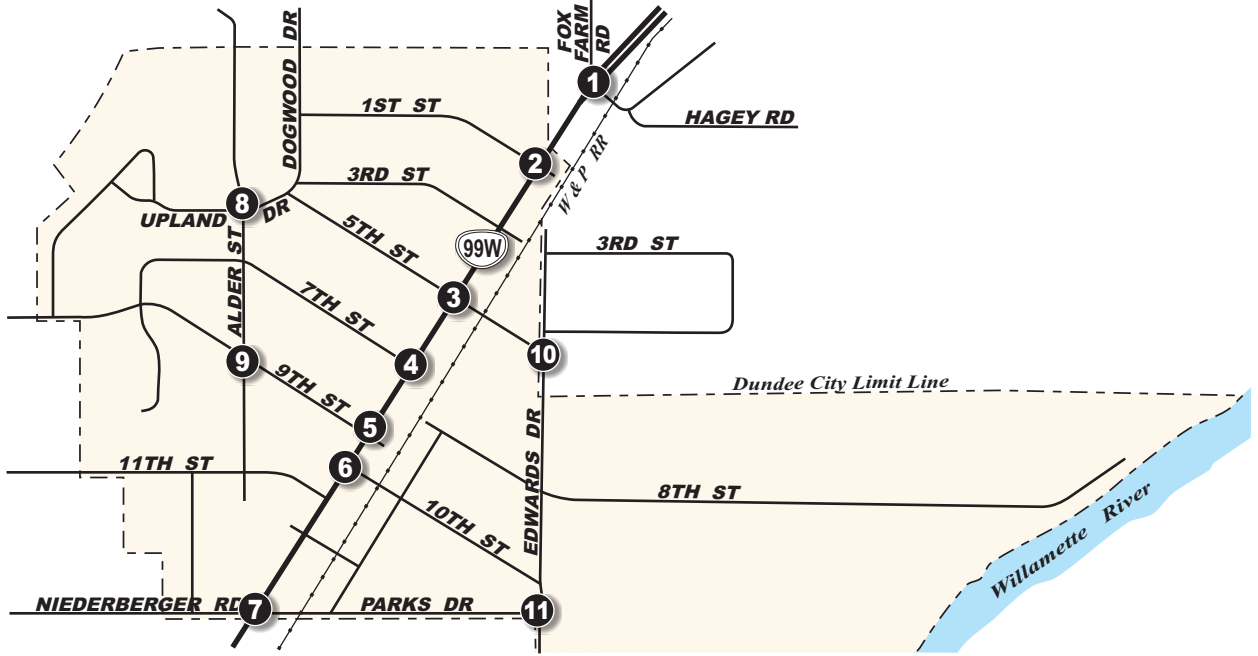

**LEGEND**

- 1** - Study Intersection
- Stop Sign
- Traffic Signal
- Lane Configuration
- 000 - PM Peak Hour Traffic Volumes
- Volume Turn Movement  
Left-Thru-Right

DKS Associates  
TRANSPORTATION SOLUTIONS

Figure **5A**

**2012 EXISTING 30 HV  
MOTOR VEHICLE VOLUMES  
(PM Peak Hour)**





NO SCALE

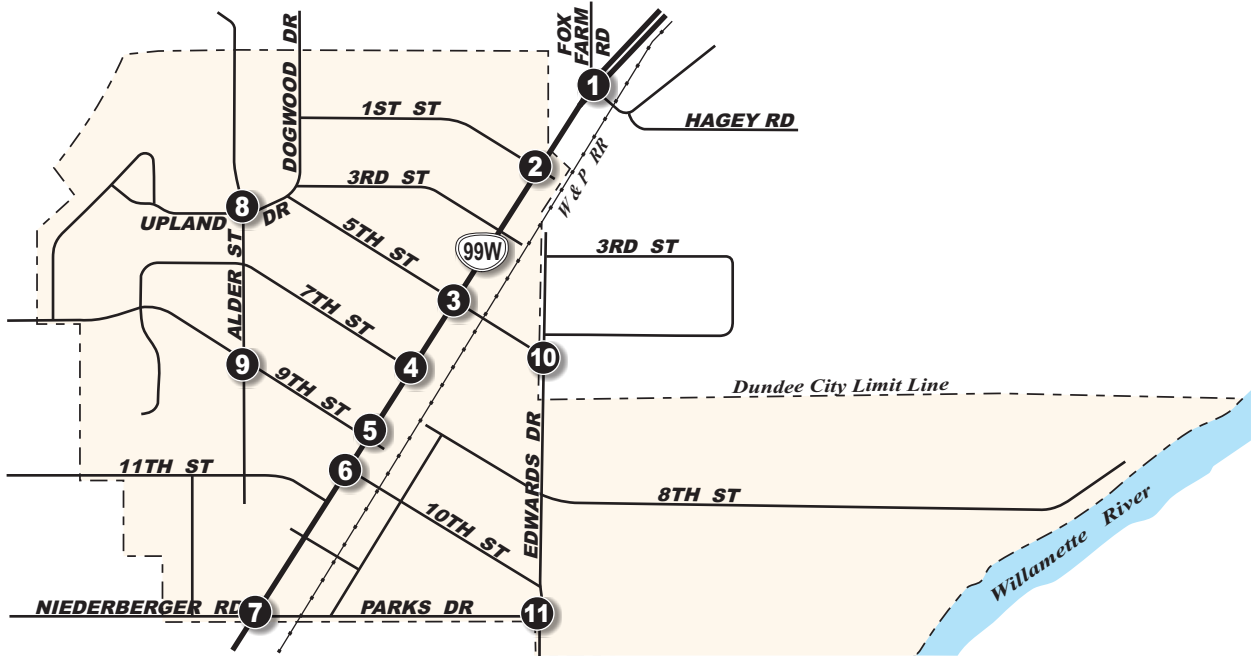

**1** OR 99W @ Fox Farm Rd.

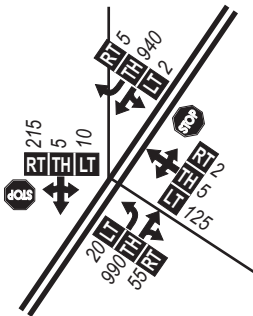

**2** OR 99W @ 1st St./Driveway

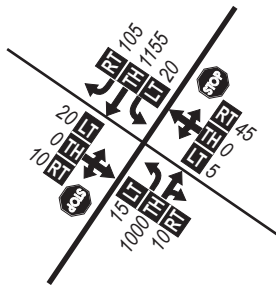

**3** OR 99W @ 5th St.

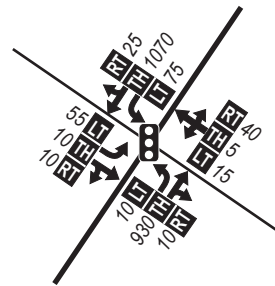

**4** OR 99W @ 7th St.

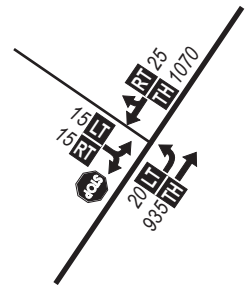

**5** OR 99W @ 9th St.

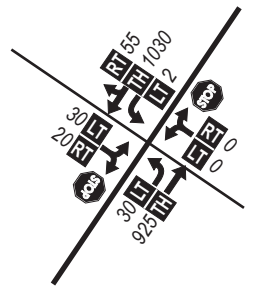

**6** OR 99W @ 10th St.

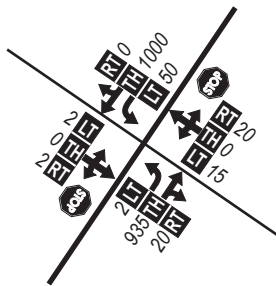

**7** OR 99W @ Niederberger Rd./Parks Dr.

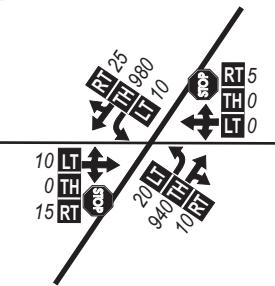

**8** Alder St. @ Upland Dr.

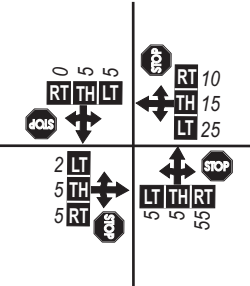

**9** Alder St. @ 9th St.

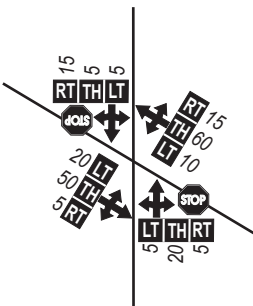

**10** Edwards Dr. @ 5th St.

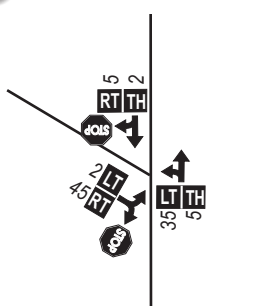

**11** Edwards Dr. @ Parks Dr.

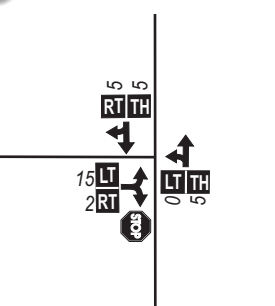

**LEGEND**

**1** - Study Intersection

← - Lane Configuration

STOP - Stop Sign

000 - PM Peak Hour Traffic Volumes

⬇ - Traffic Signal

LT TH RT - Volume Turn Movement  
Left-Thru-Right

DKS Associates  
TRANSPORTATION SOLUTIONS

Figure **5B**

**2012 EXISTING AVERAGE WEEKDAY  
MOTOR VEHICLE VOLUMES  
(PM Peak Hour)**

**Mode Choice Factors**

The choice of how to get to a destination involves a variety of factors, including which modes are available and what one’s habits are. When considering whether a trip will be taken by motor vehicle, walking, bicycle, or transit, the underlying factors affecting choice are typically ease and convenience of travel, travel cost, and travel time. These factors in turn depend on the particular destination, barriers to travel, and demographic characteristics such as age and income.

**Destination**

Dundee residents use the transportation system to make many types of trips, including work, school, shopping, and recreation. The type of trip strongly influences the mode of transportation chosen. If the trip destination is a park or an elementary school, then there is a higher likelihood that one will walk or bike because these destinations often exist in one’s neighborhood. Conversely, if the trip destination is work or shopping, a motor vehicle is probably more convenient.

**Table 2: Commute Time to Work**

Commute Length	Dundee	Yamhill Co.	Oregon
Less than 15 minutes	30%	38%	35%
15 to 30 minutes	23%	25%	37%
30 to 45 minutes	26%	18%	17%
45 minutes or more	22%	19%	11%
<b>Average commute time</b>	<b>29 min.</b>	<b>25 min.</b>	<b>22 min.</b>

Source: 2000 US Census

Dundee residents who work outside of the City are likely to commute by motor vehicle due to this mode’s time and comfort advantages over non-motorized travel and its convenience advantage over bus service. Table 2 shows the range of travel times that Dundee residents experience when commuting, and compares these to statewide figures. The Census data confirms that a significantly higher percentage of workers in Dundee have long commutes (30 minutes and higher) than is the case for typical Oregon workers. This underlines the importance of vehicular travel, whether by SOV, carpool, or transit, to the residents of Dundee.

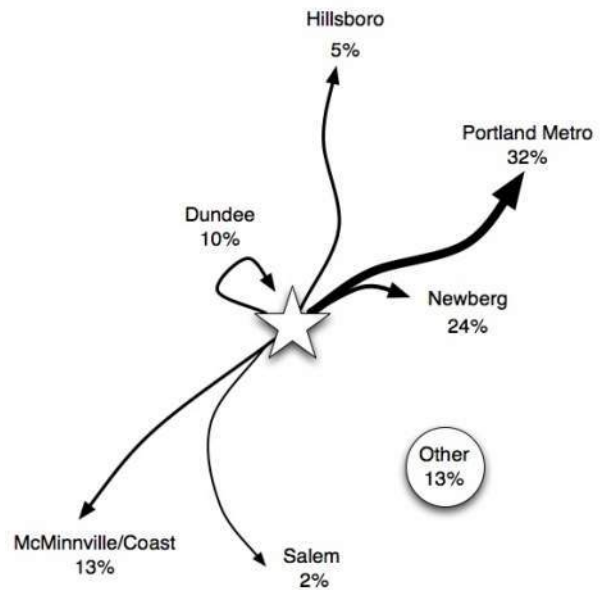

Census data also reveals the commute destinations of Dundee’s workers. As shown

on the right, a large majority of Dundee's workers commute to jobs outside of the City. Most workers commute to the north and east, with over 50% of workers bound for the Portland metropolitan area or Newberg.

### Barriers to Travel

Because Dundee is small and compact, most destinations within the City are within reasonable walking range of just about any residence. However, your likelihood of walking may depend on whether you have to cross a busy roadway or walk along a road that has no sidewalks. Crosswalks, curb ramps, complete sidewalks, and bike lanes increase the comfort and attractiveness of walking and biking. Where these facilities are lacking, particularly on busy roadways, people are discouraged from using non-motorized modes of transportation.

Another potential barrier to non-motorized travel is topography. East of 99W, the City is relatively flat, but west of 99W the City rises quickly into the Dundee Hills. While the hills and the vineyards that call them home are part of the City's character and offer views that are attractive to recreational walkers, they can also present a deterrent to walking and biking. The slope up from 99W makes non-motorized trips less comfortable and may create barriers for people with disabilities.



Hills and lack of sidewalks make walking less attractive for short trips

Also, weather conditions can be a significant factor in whether a person chooses non-motorized travel. Rain, snow, and uncomfortable temperatures may reduce the likelihood of someone walking or biking for leisure, or cause someone to use a car for a trip that in better weather they might make by foot or bicycle.

### Age and Income

Demographic characteristics like age and income typically play a role in determining how you will get to a destination. Because vehicle ownership has such a strong impact on mode choice, and because residents with lower incomes are less likely to own one or more vehicles, lower income residents often account for more trips via walking, biking, and public transportation. Age is a key factor as well, as the youngest residents cannot drive, and the oldest residents are less likely to drive. Table 3 shows that Dundee has a higher proportion of school age children than Yamhill County or the state of Oregon, with 23% of the population being under 15 years old according to the 2010 Census. Conversely, Dundee has a slightly lower proportion of people who are retirement age or older than is seen in the County or the State.

**Table 3: Dundee Residents Age Comparison**

Age	Dundee	Yamhill Co.	Oregon
Under 5 years old	7%	6%	6%
5-14 years old	16%	13%	13%
15-64 years old	67%	67%	67%
65 years old and over	10%	14%	14%
<b>Median age</b>	<b>37</b>	<b>38</b>	<b>38</b>

Source: 2010 US Census

Household income can be a major determinant of travel mode as well. Table 4 shows that Dundee has a significantly smaller proportion of lower income residents than Yamhill County or the state of Oregon. Just 10% of Dundee households earn less than \$25,000 a year, compared to 24% of households statewide. Median household income in Dundee is significantly higher than in the County or State, indicating likely higher levels of vehicle ownership and use.

**Table 4: Dundee Residents Income Comparison**

Income	Dundee	Yamhill Co.	Oregon
Under \$25,000	10%	21%	24%
\$25,000-\$49,999	19%	27%	27%
\$50,000-\$74,999	30%	21%	20%
\$75,000-\$149,999	36%	27%	24%
\$150,000 and over	5%	5%	6%
<b>Median Household Income</b>	<b>\$67,000</b>	<b>\$52,000</b>	<b>\$49,000</b>

Source: 2006-2010 American Community Survey

## What Transportation Infrastructure is Available?

Dundee residents travel to work, school, recreational, and other destinations every day, relying on the City's existing transportation infrastructure. These assets include sidewalks, off-street paths, bike lanes, roadways, and transit.

### Pedestrian Facilities

People who choose to walk to their destination in Dundee may use sidewalks or off-street paths. Pedestrian facilities also include the City's crosswalks and curb ramps.

### Sidewalks

In general, sidewalks are located along roadways and delineated from the roadway by a curb and/or planting strip, and have a hard, smooth surface such as concrete. The ODOT standard for sidewalk width is six feet, with a minimum width of five feet acceptable on local streets. Dundee requires five-foot sidewalks on its collectors and local streets. Pedestrian travel on the sidewalk should be unobstructed by utility poles, sign posts, fire hydrants, vegetation, and other street furnishings.

Figure 6 shows that while some key roadways provide sidewalks on both sides of the street, many do not, including a segment on the south end of 99W. This gap in the sidewalk system hinders the accessibility of Dundee's primary transit route, which stops near the south end of the City in both northbound and southbound directions. A Transportation Enhancements grant recently obtained by the City and other funds obtained as part of a 99W preservation project will complete these unconnected sidewalks in the near future.

Providing safe pedestrian and bicycle access to school is important in promoting physical fitness for school-age children and creating healthy travel habits that will carry into adulthood. Dundee's pedestrian infrastructure provides important connections for children and families traveling to and from school from nearby residential neighborhoods, although some sidewalks are incomplete to the west of



**99W south of 12<sup>th</sup> Street: part of the City's incomplete sidewalk network**



**Off-street paths provide multimodal connections from cul-de-sacs**



Dundee Elementary School.

### On-Street Walkways

There are two areas where the pedestrian way is part of the street surface, and is delineated by striping. These locations are on the north side of 5<sup>th</sup> Street between Dogwood Drive and Dundee Elementary School, and on the west side of Alder Street between 7<sup>th</sup> Street and Upland Drive.

### Off-Street Paths

Because Dundee lacks a completely connected grid, particularly to the west of 99W, public-off-street paths are provided at key locations to connect cul-de-sacs to neighboring streets. These paths are paved and meet Americans with Disabilities Act (ADA) standards.

### Crosswalks and Ramps

As shown in Figure 6, Dundee has several marked crosswalks on 99W, although only the 5<sup>th</sup> Street intersection provides a signal. One other crosswalk is provided on Edwards, and curb ramps are provided throughout the City. Many locations lack curb ramps, however, and these locations are also apparent in Figure 6.

### Bicycle Facilities

Because existing streets in Dundee were developed as rural County roads or local residential streets, bike lanes are only found on 99W. However, the City's streets generally feature low volumes of motor vehicle traffic, and are suitable for shared use by cyclists. Available bicycle arking at key destinations is also an important part of bicycle infrastructure.

### Shared Roadway

Shared roadways occur where bicycles and motor vehicles share the same travel lane. The most appropriate roadways for this type of shared use are those with low speeds (25 m.p.h. or less) and low traffic volumes (3,000 vehicles per day or fewer)<sup>4</sup>. **Signed** shared roadways are where facilities are designated and signed as bicycle routes and serve to provide continuity to other bicycle facilities (e.g., bicycle lanes) or to designate a preferred route through a community. Such a route is typically signed with Manual on Uniform Traffic Control Devices (MUTCD) green bicycle signs with directional arrows. Shared roadways can also be signed to provide directional information for cyclists, providing destination, time, and distance information (e.g., "City Hall, 3



Example shared roadway sign (Oregon Bicycle and Pedestrian Plan)

<sup>4</sup> The Federal Highway Administration's *Manual on Uniform Traffic Control Devices* guidance states that shared lane markings should not be placed on roadways with a speed limit above 35 m.p.h. <http://mutcd.fhwa.dot.gov/>

minutes, 1/2 mile”).

All local streets in Dundee are low speed, low volume roadways that could be classified as shared roadways. Although there are no signs or pavement markings to indicate that a particular local street is a shared roadway or a preferred bicycle route, these low traffic roadways connect residential areas with important traffic generators throughout Dundee. This allows cyclists to avoid using 99W in favor of quieter, more comfortable streets.

### Bike Lanes

Bike lanes are portions of the roadway designed specifically for bicycle travel with a striped lane and stenciling indicating bicycle use. ODOT standard width for a bike lane is six feet. The minimum width of a bicycle lane against a curb or adjacent to on-street parking is five feet. A bicycle lane as narrow as four feet is allowed, but only in very constrained conditions. Dundee street standards defer to ODOT requirements<sup>5</sup>, with specific bikeway locations to be determined by the City. Existing bicycle facilities in Dundee are shown in Figure 6.

Bike lanes in Dundee are limited to 99W, where the shoulder is striped and bike stenciling is provided nearly all the way through the City, with only the section north of 1<sup>st</sup> Street being an unmarked shoulder bikeway. Bike lane width varies along the roadway, but is typically 4-5 feet.

### Bike Parking

Where you store your bike when you get to your destination is an important part of bicycle infrastructure. If there is nowhere safe and secure to park your bike, then you are less likely to ride even if your trip distance and the roadway facilities are right for cycling.

On-street bike parking is not evident in Dundee, but where bike parking is provided in a prominent location, such as at Dundee Elementary School, it appears to be well used.



**Bicycle parking is well utilized at Dundee Elementary School, even in winter**

<sup>5</sup> Bikeway facilities shall meet the requirements of Dundee Public Works' Street Standards and the American Association of State Highway and Transportation Officials (AASHTO) *Guide for Development of New Bicycle Facilities*, as amended and adopted by ODOT.



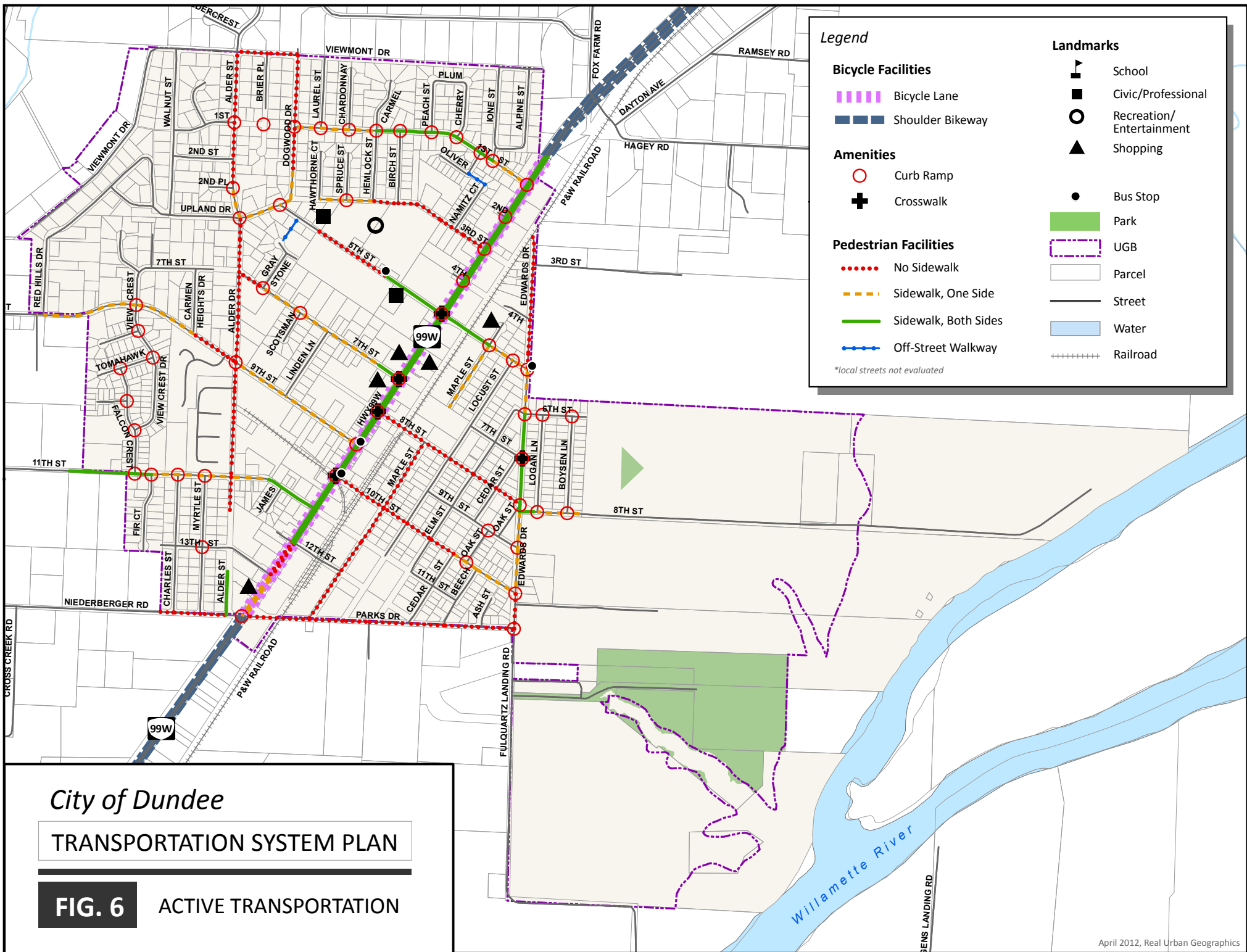

## Transit Service

Transit service is provided in Dundee by Yamhill County Transit Area (YCTA), which provides two fixed bus routes connecting Dundee to destinations along the 99W corridor, including McMinnville, Newberg, Sherwood, and Tigard. YCTA also provides an Americans with Disabilities Act (ADA) dial-a-ride service. Fixed transit routes in Dundee are shown in Figure 7.

### Bus Service on the 99W Corridor

YCTA Route 44, also known as the 99W Link, runs from downtown McMinnville to Tigard Transit Center with one stop in Dundee northbound at 9<sup>th</sup> Street, and southbound at 10<sup>th</sup> Street. Key destinations along this route include the central business districts in McMinnville, Newberg, and Tigard. These destinations include activity generators like Linfield College, George Fox University, and the Tigard Transit Center, which provides connections throughout the Portland metro area.

Route 44 provides service at one-hour frequencies in the a.m. and p.m. peak hours, and two-hour frequencies in mid-day, between 6:00 a.m. and 7:00 p.m. YCTA Route 46S provides service on the same route on Saturdays, with four trips each way between 8:00 a.m. and 7:00 p.m.

### Bus Service to Newberg

YCTA also operates Route 4, which connects Newberg and Dundee. Route 4 provides service to the same stops on 99W at 9<sup>th</sup> and 10<sup>th</sup> Streets, but also provides two stops on the northern side of the City, off of 99W. This route provides more stops within Newberg as well, providing more direct access to destinations such as schools, parks, and grocery stores. Route 4 provides service at one-hour frequencies between 7:00 a.m. and 7:00 p.m. Monday through Friday.

### Transit Service for People with Disabilities

YCTA provides demand response (dial-a-ride) service for people with disabilities who are unable to use regular fixed route buses, and also for people whose origins and/or destinations are not within close proximity (generally  $\frac{3}{4}$  mile) of YCTA's fixed route services. This curb-to-curb service, provided by smaller buses equipped with wheelchair lifts, is available Monday through Friday between 8:00 a.m. and 4:30 p.m.



**Curb-to-curb service is provided by Yamhill County Transit Area**

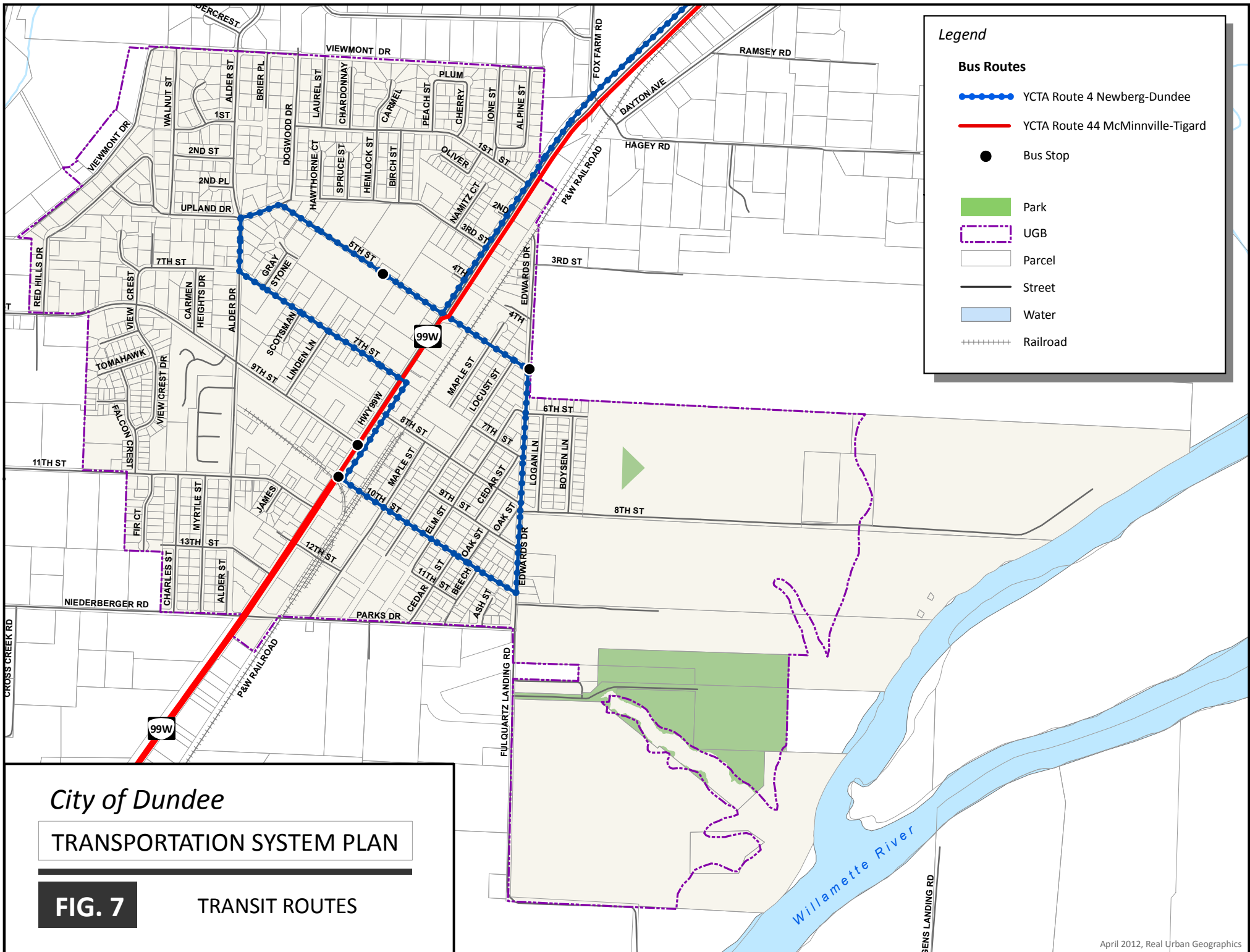

### Transit Access and Amenities

Dundee's primary transit stops are on 99W near the southern end of the City. The southbound stop at 10<sup>th</sup> Street is unmarked, and features a bench outside the Dundee Women's Club building. The northbound stop is signed and provides a shelter for travelers waiting for buses bound for Newberg and the Portland metro area. Considering the additional two stops for Route 4 to Newberg, nearly all Dundee residences are within a half-mile of a bus stop.



Shelter for northbound travelers at 9<sup>th</sup> Street on Highway 99W



## Roadways

Within Dundee, roadways are under the jurisdiction of the City, Yamhill County and ODOT. Roadways are organized by **functional classifications**, which provide a hierarchy of intended purposes (as shown in Figure 8). Roadways with a higher intended usage generally have a classification and related standards that promote more efficient vehicle movement through the City, while roadways with lower intended usage are classified to provide greater access to local destinations such as businesses or residences.



Late afternoon traffic on Highway 99W

Highway 99W is classified by ODOT as a Principal Arterial. Arterials serve both local and through traffic, and distribute traffic to and from the collector system. 99W has by far the highest traffic volumes in Dundee, it is the roadway that residents use to connect to locations outside the City, and it is the roadway that visitors use to reach and travel through Dundee. The posted speed limit on 99W has recently been reduced to 30 miles per hour through Dundee.

Roadways that connect neighborhoods and major activity generators to principal arterials are generally classified as collectors. They provide greater accessibility to neighborhoods than arterials, and provide efficient through movement for local traffic. 9<sup>th</sup> Street (which becomes Worden Hill Road west of Dundee, and is under Yamhill County jurisdiction west of Alder Street) is an example of a collector street that connects popular wineries just outside the City as well as local neighborhoods to 99W. Collectors have a posted speed of 25 miles per hour within Dundee.

Roadways that provide more direct access to residences are typically classified as local streets. This classification is typically a low volume street, often lined with residences. All local City streets are posted at 25 miles per hour.



Wineries, parks, and other activity west on 9<sup>th</sup> Street

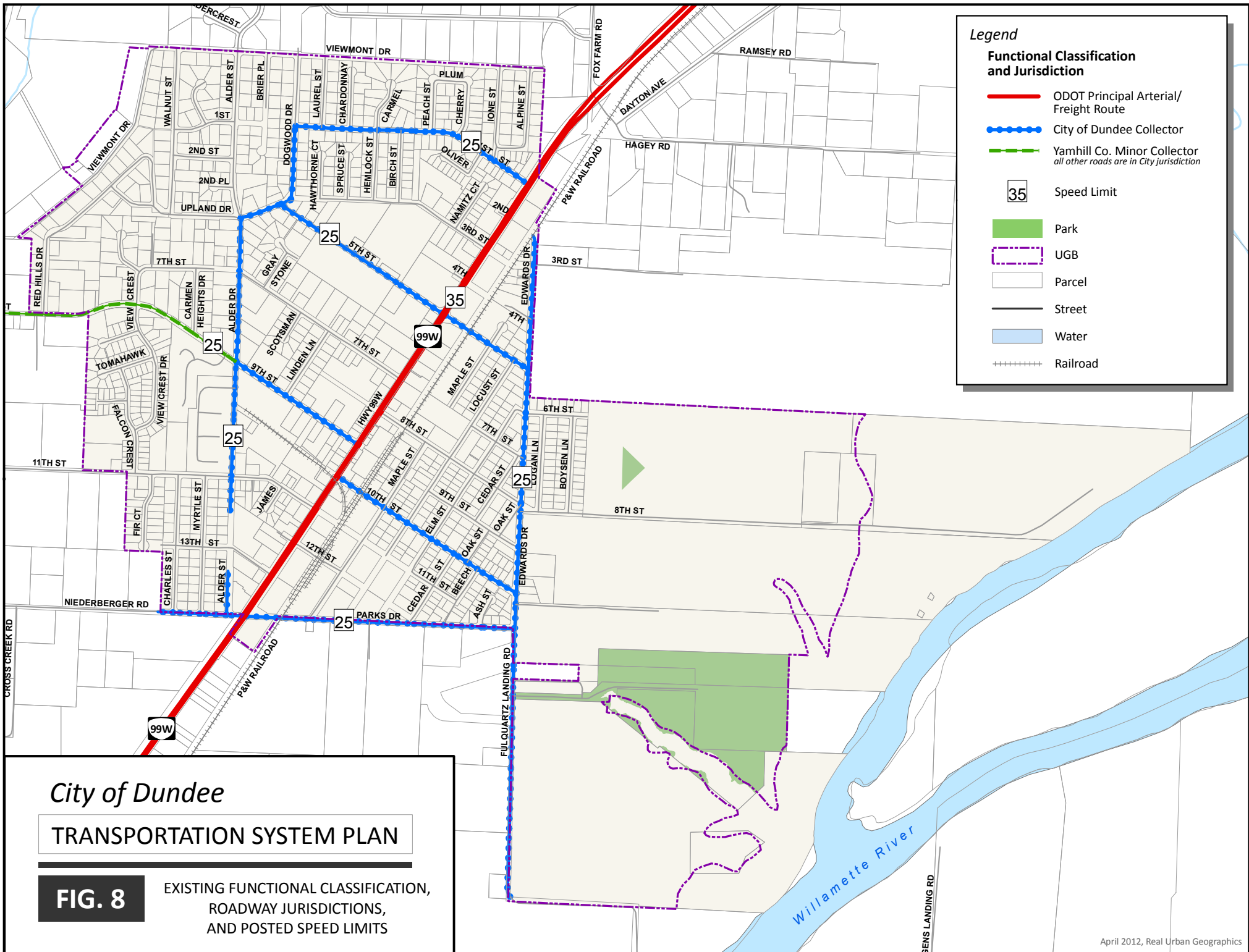

## Freight

ODOT classifies Highway 99W as a freight route through the City of Dundee. Truck freight movements in Dundee involve shipments both to and from locations in the City, and shipments that pass through the City, mainly on 99W. Congestion on this facility currently slows freight movement to and through Dundee. Freight volumes on 99W around 5<sup>th</sup> Street are around 100 trucks in each direction during the evening peak hour. Truck percentages in mid-day off-peak hours (9:00 a.m. to 4:00 p.m.) are generally 11-13% of all traffic on 99W.

## Rail

The Willamette & Pacific Railroad (WPRR) operates a rail line that runs parallel to 99W through Dundee. Rail freight originating in the western Willamette Valley is carried on WPRR tracks as far north as Newberg, and on Portland & Willamette Railroad (PNWR) tracks the rest of the way into Portland.

The Federal Railroad Administration has established six track classes, which set maximum speeds for freight and passenger trains, based on the track condition. The track within the study area is classified as Class 2, which limits freight trains to 25 mph and passenger trains to 30 mph. The line is currently used for freight movement, and has one train operating daily in each direction with up to two additional smaller trains operating periodically. There are no passenger rail services near the study area, with the nearest Amtrak stations located in Portland, Oregon City, and Salem.

In 2008, Yamhill County completed a feasibility study for development of an improved rail system for passengers and freight.<sup>6</sup> Objectives were to evaluate infrastructure and develop a ridership estimate for a Yamhill County commuter rail service. One recommendation of this study was to take actions to preserve the integrity of existing rights-of-way to retain and enhance passenger and freight transportation options in the future.

## Air

No public airports are located within Dundee. The closest is Sportsman Airpark in Newberg, four miles north. It has one paved 2,800-foot runway and averages 14,000 operations (takeoffs or landings) per year. Approximately 55 aircraft are based at the airport. The Sportsman Airpark provides general flight instruction and airplane rental and maintenance services, as well as private helicopter and recreational hot-air ballooning services.

A larger general aviation airport is located approximately 12 miles north of Dundee, in Hillsboro. The Hillsboro Airport serves approximately 200,000 operations annually. It is owned by the Port of Portland and has two paved runways (6,600 feet and 4,000 feet). There are three fixed-base operators at the airport, and the airport provides all the facilities to support jet- and propeller-driven aircraft and helicopters.

---

<sup>6</sup> *Feasibility Study for Development of an Improved Yamhill County Rail System for Passengers and Freight, Final Report*. Yamhill County, 2008.



The nearest airport with scheduled passenger service is the Portland International Airport, located approximately 30 miles northeast of Dundee. This airport is also owned by the Port of Portland and has three runways (7,000 feet, 8,000 feet, and 11,000 feet). The Portland International Airport serves more than 13.7 million passengers and 270,000 tons of cargo annually.

### **Waterway**

The Willamette River is located east of Dundee and provides potential opportunities for recreational boating. The new Chehalem Paddle Launch, operated by the Chehalem Park and Recreation District, takes access to the river at the end of 8<sup>th</sup> Street and provides a public kayak and canoe launch site. Additional access is located approximately four miles to the north at Rogers Landing County Park in Newberg.

### **Pipeline**

Northwest Natural currently runs a 6" high-pressure transmission line through Dundee that gets converted to a 4" transmission line within the city. There is also a Class C (or higher) regional NWN transmission main that supplies Dundee. There are no gate stations or storage facilities currently located within Dundee. Dundee residents who live on a street where a natural gas distribution line already exists can be easily connected to that distribution line.

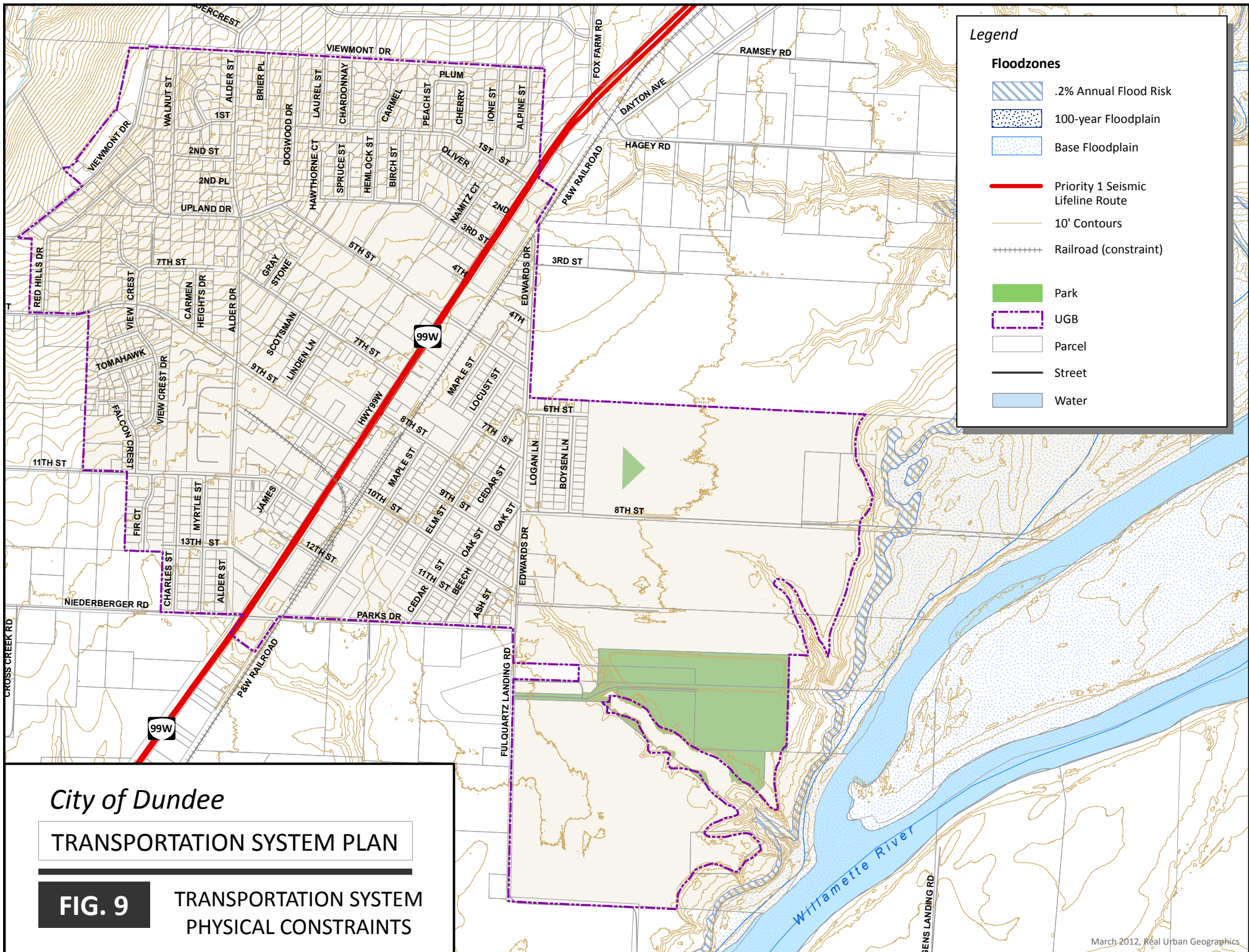

## How is System Performance Measured?

Maintaining an acceptable level of performance for Dundee's transportation infrastructure requires a variety of analytical tools and assessment types. The measures used to monitor the transportation system are shown below.

### Collisions

The safety of the roadways and intersections in Dundee were monitored through collision data as part of the TSP Update. The data was reviewed to identify potential patterns for motor vehicle, pedestrian, and bicyclist collisions.

### Pedestrian, Bicycle, and Transit Facilities

The facilities of alternative modes to motor vehicle were reviewed as part of this TSP Update to identify facility deficits or potential connectivity or access improvement opportunities.

### Roadway Jurisdiction

The standards and maintenance responsibilities of the various roadways depend on the roadway's jurisdiction. In Dundee, roadways are under the jurisdiction of either the City, Yamhill County, or ODOT. Each responsible jurisdiction sets standards for the roadways to maintain their intended functional classification, which vary depending on the design speed, connectivity and the priority for access to fronting properties. Higher speed, regional facilities are used primarily for longer trips, while lower speed local city streets are used primarily to access homes, shops, schools and jobs.

### Mobility Targets

Mobility is an important consideration because it measures how freely vehicle traffic can move along to its intended destination. In general, roadway systems have their highest degree of conflicts and associated congestion at intersections, and so the performance of a system is often defined by how well the intersections function.

There are two methods used to gauge these conditions – one is numeric, and one is a letter grade. ODOT prefers the numeric volume-to-capacity ratio method (see below) while Yamhill County and the City uses a letter grade derived from the Level of Service method.

All intersections in Dundee must operate at or below the adopted targets or mitigation would be necessary to approve future growth. All intersections under State jurisdiction must comply with the v/c ratios in the 1999 Oregon Highway Plan (OHP), while intersections under Dundee and Yamhill County jurisdiction must meet those respective agencies' LOS standards. The adopted intersection performance targets vary by jurisdiction of the roadways. For Dundee and Yamhill County, the target is Level of Service D. For ODOT, the target for OR 99W is a volume-to-capacity ratio of 0.85.

**Table 5: Mobility Targets by Jurisdiction**

Jurisdiction	Performance Method	Mobility Target
<b>ODOT</b>	<p><b>Volume-to-capacity (v/c) ratio</b> is a decimal representation (between 0.00 and 1.00) of the proportion of capacity that is being used (i.e., the saturation) at a turn movement, approach leg, or an intersection. It is determined by dividing the peak hour traffic volume by the hourly capacity of a given intersection or movement.</p> <p>A lower ratio indicates smooth operations and minimal delays. As the ratio approaches 1.00, congestion increases and performance is reduced. If the ratio is greater than 1.00, the turn movement, approach leg, or intersection is oversaturated and usually results in excessive queues and long delays.</p>	<p>The OHP v/c threshold for 99W is 0.85</p> <p>99W is classified as a freight route on a Statewide Highway with a posted speed of 30 m.p.h.<sup>7</sup></p>
<b>City of Dundee</b>	<p><b>Level of service (LOS):</b> A “report card” rating (A through F) based on the average delay experienced by vehicles at the intersection.</p> <p>LOS A, B, and C indicate conditions where traffic moves without significant delays over periods of peak hour travel demand.</p> <p>LOS D and E are progressively worse operating conditions.</p> <p>LOS F represents conditions where average vehicle delay has become excessive and demand has exceeded capacity. This condition is typically evident in long queues and delays.</p>	Level of Service D <sup>8</sup>
<b>Yamhill County</b>	Same as Dundee	Same as Dundee

<sup>7</sup> Oregon Highway Plan, Policy 1F, Table 6

<sup>8</sup> Dundee TSP (2003), p. 98, Policy A.11 under General Transportation Network Policies

## Access Spacing

Access spacing is a broad set of techniques to balance the need to provide efficient, safe, and timely travel with the ability to allow access to individual destinations. Typically, more driveways and intersections along a roadway means more potential conflict points and less efficient operations. Proper implementation of access management techniques will promote reduced congestion, reduced collision rates, less need for additional highway capacity, conservation of energy, and reduced air pollution. ODOT, Yamhill County, and the City of Dundee have adopted access spacing standards, with each applying to roadways under their respective jurisdictions (see Table 6).

**Table 6: Spacing Standards for Dundee Streets**

Facility	Spacing Standard
ODOT Statewide Highway (Urban)	500 feet
City of Dundee Collectors	75 feet
City of Dundee Local Streets	15 feet
Yamhill County public roads	500 feet

Source: Table 4 in Oregon Administrative Rules 734-51,  
<http://www.oregon.gov/ODOT/HWY/ACCESSMGT/docs/pdf/734-051.pdf>  
 Dundee Development Code, Section 2.202.08, Access Management  
 Yamhill County TSP, Access Management Policy 8

## Freight Routes

Efficient truck movement plays a vital role in the economical movement of raw materials and finished products. The designation of through truck routes provides for this efficient movement, while at the same time maintaining neighborhood livability, public safety, and minimizing maintenance costs of the roadway system. ODOT has identified Highway 99W as a Freight Route and Truck Route through Dundee.

## Seismic Lifeline Routes

ODOT has designated certain routes to be maintained for emergency response in the event of an earthquake. In Dundee, Highway 99W is classified in the 2010 ODOT Emergency Operations Plan as a Priority 1 Lifeline Route, considered essential for emergency response within the first 72 hours after an event. There are no other lifeline routes within the City.

Seismic Lifeline Routes were identified by local emergency coordinators in 1995. Based on the geological analysis available at the time, these routes were determined to most likely be available after a seismic event. The routes were initially used to help assess the need for retrofitting state and local bridges. ODOT is currently in the process of updating the list of designated routes. This effort is expected to be complete in late 2012.



## Revenue

Dundee funds needed improvements to the transportation system from a number of revenue sources as listed in Table 7. These limited funds are allocated to expenditures including materials, personnel, maintenance, and system improvements. On average, the City has approximately \$69,000 per year to fund system improvements, which would total approximately \$1.7 million over a 25-year horizon if current funding levels are maintained.

**Table 7: Dundee Transportation Funding (2011 Dollars)**

Revenue Source	Average Annual Amount
State Highway Fund Shared Revenue	\$131,000
Local Motor Vehicle Fuel Tax	\$73,000
Miscellaneous Revenues	\$5,000
Settlement	\$10,000
<b>Total Revenues (4-year average)</b>	<b>\$219,000</b>
Expenditures	Average Annual Amount
Personnel Services	\$52,000
Materials and Services	\$96,000
Equipment Reserve	\$3,000
<b>Total Expenditures (4-year average)</b>	<b>\$150,000</b>
<b>Revenue Over Expenditures (Available for Capital Improvements)</b>	<b>\$69,000</b>

Source: City of Dundee, 2012

Revenues and expenditures vary from year to year. The City of Dundee is expected to contribute a significant local match for construction of Phase 1 of the Newberg-Dundee Bypass. Depending on the terms, the City may have debt service of \$20,000 a year or higher over a 20-year period.

### What Conditions Do Transportation System Users Face?

This section uses the measures discussed above to evaluate performance of the existing transportation infrastructure.

#### Collision Evaluation

Collision data from the most recent three years of available data (2008 to 2010) for all roadways in Dundee was obtained from ODOT and reviewed. Over the past three years, 99 collisions occurred in Dundee. A majority of these collisions (about 72 percent) were rear-end collisions (see Figure 10). This is a high proportion for this collision type. For comparison, the percentage of rear-end collisions throughout the whole county was only 30% over 2008-2010. See the section on 99W segment collisions below for more discussion. No collisions involving pedestrians or bicyclists were reported over the three-year span in Dundee.

The severity of the collisions in Dundee over the past three years is illustrated in Figure 11. Severities of the collisions were generally low, with no fatalities. 45 of them were injury collisions, and the other 54 were property damage only.

#### Intersection Collisions

The total number of crashes experienced at an intersection is typically proportional to the number of vehicles entering it. Therefore, a crash rate describing the frequency of crashes per million entering vehicles (MEV) is used to determine if the number of crashes should be considered high. Using this technique, a collision rate of 1.0 MEV or greater is commonly used to identify when collision occurrences are higher than average and should be further evaluated.

As shown in Table 8, crash rates were calculated (based on the past three years of collision data) for each of the 11 intersections reviewed in Dundee. The crash rate at one intersection is above the 1.0 per million entering vehicles (MEV) threshold, generally indicating that the frequency of

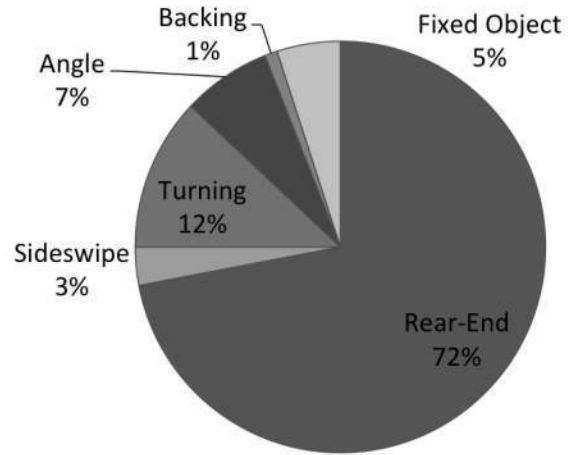

Figure 10: Dundee Collisions by Type, 2008-2010

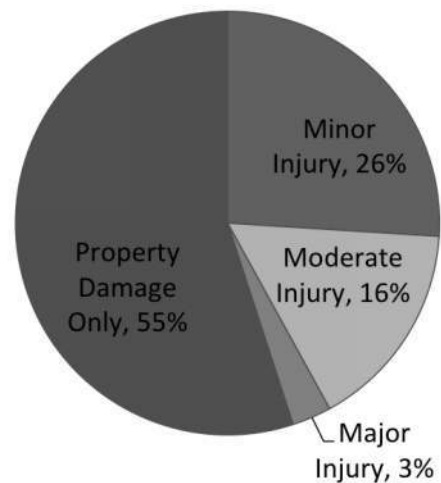

Figure 11: Dundee Collisions by Severity



collisions is high for the volume of traffic served. The collisions were further evaluated at this intersection to see if any trends exist.

**Table 8: Intersection Collision Evaluation**

Intersection	PM Peak Hour Total Entering Volume	Collision Rate
<b>Signalized Intersections</b>		
Highway 99W/5 <sup>th</sup> Street	2,255	0.57
<b>Unsignalized Intersections</b>		
Highway 99W/Fox Farm Road	2,370	0.00
Highway 99W/1st Street*	2,385	0.53
Highway 99W/7 <sup>th</sup> Street	2,080	0.33
Highway 99W/9 <sup>th</sup> Street*	2,090	0.56
Highway 99W/10 <sup>th</sup> Street	2,040	0.24
Highway 99W/Niederberger Road	2,015	0.15
Upland Drive/Alder Street	135	0.00
<b>9<sup>th</sup> Street/Alder Street*</b>	<b>215</b>	<b>1.37</b>
5 <sup>th</sup> Street/Edwards Street	90	0.00
Parks Drive/Edwards Street	30	0.00

Source: ODOT Crash Data System

\* Intersection collision rate exceeds 1.0, but does not exceed 2010 Highway Safety Manual critical crash rate of 1.69 per MEV for local street intersections in the City of Dundee.

The highest collision rate occurs at the intersection of 9<sup>th</sup> and Alder. This intersection is unsignalized, with vehicles on Alder Street stopping and vehicles on 9<sup>th</sup> Street allowed free movement. Alder Street runs north-south, while 9<sup>th</sup> Street runs diagonally to the northwest and southeast, making visibility difficult for vehicles stopped at Alder Street. All three of the collisions at this location were of the angle variety, and all were property damage only. In one case, a vehicle ran a stop sign, and in the other two a vehicle did not yield the right of way. This may indicate that drivers on Alder are having difficulty seeing cross traffic on 9<sup>th</sup> from a legal stopping position (behind the stop sign), and are edging out into the intersection to improve sightline. Safety at this intersection should continue to be monitored as vehicle volumes grow in the future.

### Roadway Segment Collisions

How does collision frequency on Highway 99W in Dundee compare to other state highways in Oregon? Crash rates identifying the number of crashes per million vehicle-miles traveled for 99W, as well as statewide average crash rates for similar facilities, were obtained from ODOT's 2010 State Highway Crash Rate Tables.<sup>9</sup> For comparison against statewide averages, Highway

<sup>9</sup> 2010 State Highway Crash Rate Tables. Retrieved March 2012 from ODOT website: [http://www.oregon.gov/ODOT/TD/TDATA/car/CAR\\_Publications.shtml](http://www.oregon.gov/ODOT/TD/TDATA/car/CAR_Publications.shtml)

99W was classified as a non-freeway principal arterial through an urban city. The reported crash rates are shown in Table 9.

**Table 9: State Highway Collision Rate Comparison**

Facility	Crashes per Million Vehicle Miles				
	2010	2009	2008	2007	2006
Highway 99W through Dundee (0.94 mi)*	3.79	2.78	2.84	2.92	2.91
Similar ODOT facilities	2.49	2.36	2.37	2.38	2.37

Source: ODOT 2010 State Highway Crash Rate Tables

\* Highway 99W mile points 25.52 to 26.46

The 99W segment through Dundee, which is just under a mile long, had a higher collision rate than the statewide average for all five years. The percentage of collisions occurring on 99W that were rear-end type was 81% in 2008-2010, again, significantly higher than the countywide figure of 30%.

#### ODOT High Collision Locations

Highway 99W through Dundee contains two sites that rank among the top ten percent for state highways in Oregon according to the Safety Priority Index System (SPIS) for 2011.<sup>10</sup> The two sites are:

- Mile point 25.74 to 25.92 (approximately 4<sup>th</sup> Street to 6<sup>th</sup> Street) on 99W has been identified as a top 10% location, but not a top 5% location.
- Mile point 25.44 to 25.62 (approximately the northern city limits to 2<sup>nd</sup> Street) on 99W has been identified as a top 5% location. Top 5% locations are flagged for further investigation by the Region traffic unit. Investigation confirmed that the primary crash pattern was rear-end, and higher than expected crashes resulted from vehicles following too closely. The investigation concluded that heavy congestion was a likely cause, and that the recently implemented speed limit reduction from 35 m.p.h. to 30 m.p.h., as well as the upcoming bypass project, would help improve conditions.

<sup>10</sup> 2011 ODOT Safety Priority Index System (SPIS), <http://www.oregon.gov/ODOT/HWY/TRAFFIC-ROADWAY/spis.shtml>. SPIS ranks locations based on a combination of crash frequency, rate, and severity.

### Pedestrian Conditions

The existing pedestrian infrastructure in Dundee provides good connections that help encourage people to walk to key destinations such as school, transit stops, and shopping destinations on 99W. A number of recent sidewalk improvements, particularly on 99W and on Edwards Street, help provide good pedestrian connectivity. However, there are a number of conditions that create barriers for pedestrians and people in wheelchairs.

#### Curb ramps

Many street corners in Dundee include curb ramps. These vary in quality, with many in need of repair, particularly on 99W, where roadway settling or lack of adequate drainage could be a limitation. Curb ramps that slope down into potholes create major barriers for people with disabilities. Also, new off-street facilities, such as the pedestrian connection between Graystone Drive and 5<sup>th</sup> Street, could be constructed with curb ramps to accommodate bicycles and other rolling modes.

#### Pedestrian Crossings

Dundee has five locations with marked pedestrian crossings, with four on 99W and one at the intersection of 7<sup>th</sup> Street and Edwards Street. On 99W, there are crosswalks on all four legs of the signalized intersection at 5<sup>th</sup> Street. However, the crosswalks at 7<sup>th</sup>, 8<sup>th</sup>, and 10<sup>th</sup> do not have any kind of signal or other treatment to increase visibility, and field observation showed that motor vehicles do not often yield to pedestrians. The crosswalk at 10<sup>th</sup> in particular is important since it provides critical access to Dundee's main bus stops at 9<sup>th</sup> and 10<sup>th</sup> Streets. This location would benefit from a high visibility pedestrian crossing treatment such as a rapid flashing beacon.



Curb ramp on 99W descending into deteriorated pavement



Off-street connection at 5<sup>th</sup> and Graystone does not include ramp



Crosswalk at 10<sup>th</sup> Street is signed but not signalized

An ODOT Highway 99W preservation project scheduled for 2013 will include upgrades of all curb ramps along 99W in Dundee to meet current standards. Existing crosswalks at 7<sup>th</sup>, 8<sup>th</sup>, and 10<sup>th</sup> Streets will be removed, and a permit will be required to re-establish a crosswalk at an unsignalized intersection. Pedestrian activated signals are envisioned at new crossing locations.

### Bicycle Conditions

Although Dundee generally has a grid of low-volume streets that have good potential for bicycle use, the City does not have a coherent bike network. Highway 99W has striped bike lanes, but there are no marked bike facilities on any of the local streets. Despite the lack of designated facilities, many Dundee residents do ride their bicycles to key destinations, particularly school. Many cyclists, as well as pedestrians, use 5<sup>th</sup> Street as well as an unmarked dirt path across from the school (between 5<sup>th</sup> Street and 7<sup>th</sup> Street) to meet their travel needs.



**Informal pedestrian/bike connection from 7<sup>th</sup> Street to Dundee Elementary**

Dundee's lone bicycle facility is the striped bike lanes on 99W. While the City's north-south local streets are likely more attractive routes for local trips, the lanes on 99W are important for cyclists making longer trips towards Newberg, the Portland metro area, or the Oregon coast. Field observation revealed that 99W's bike lanes are not well maintained, with a lot of debris near the curb. These conditions sometimes result in cyclists encroaching on the vehicular travel lane, which can be a safety issue.

Just as it does for pedestrians, 99W presents a barrier for cyclists trying to get between the east and west sides of the City. The traffic signal at 5<sup>th</sup> Street allows for comfortable crossings, but cyclists face major challenges when trying to cross at any other location. High traffic levels provide few "gaps" for cyclists who wish to cross as a vehicle would, and cyclists who dismount and attempt to cross as a pedestrian face issues with motor vehicles not yielding, as discussed in the Pedestrian Conditions section above.



**Cyclist on 99W avoiding debris in bike lane**

## Motor Vehicle Conditions

The motor vehicle conditions in Dundee vary based on the time of year. Operations at the 11 study intersections, shown in Table 10, were evaluated during the p.m. peak hour of the peak seasonal period (August) as described in the Motor Vehicle Volumes section of this document.

**Table 10: Intersection Operations (2012 p.m. peak)**

Intersection	Mobility Target	Peak Seasonal		Average Weekday	
		V/C Ratio	LOS	V/C Ratio	LOS
<b>Signalized Intersections</b>					
Highway 99W/5 <sup>th</sup> Street	0.85	0.78	C	0.75	C
<b>Unsignalized Intersections*</b>					
Highway 99W/Fox Farm Road	0.85	> 1.0	F	> 1.0	F
Highway 99W/1 <sup>st</sup> Street	0.85	0.27	E	0.20	D
Highway 99W/7 <sup>th</sup> Street	0.85	0.27	E	0.20	D
Highway 99W/9 <sup>th</sup> Street	0.85	0.33	E	0.29	D
Highway 99W/10 <sup>th</sup> Street	0.85	0.20	D	0.18	D
Highway 99W/Niederberger Road	0.85	0.17	D	0.13	C
Upland Drive/Alder Street	D	0.21	A	0.17	A
9 <sup>th</sup> Street/Alder Street	D	0.05	B	0.05	B
5 <sup>th</sup> Street/Edwards Street**	D	0.06	A	0.05	A
Parks Drive/Edwards Street	D	0.03	A	0.02	A

\*V/C ratio and LOS reported for the worst minor street approach

\*\*Intersection configuration not allowed in HCM analysis, therefore intersection configuration was modified to allow for capacity analysis.

Capacity analysis indicates that intersections on 99W perform particularly poorly on the north end of Dundee. The intersection of 99W/Fox Farm Road exceeds the ODOT mobility target, with extremely high delay and V/C ratio for the westbound left in particular, from Fox Farm Road onto 99W. Left turns from 99W itself operate with little delay.

Stop sign-controlled intersections at 1<sup>st</sup>, 7<sup>th</sup>, and 9<sup>th</sup> Streets experience high delays (LOS E), exceeding City LOS standards under peak seasonal conditions. Capacity analysis shows that the eastbound 7<sup>th</sup> Street approach has the most delay of these intersections, at about 45. This represents an average delay for a vehicle waiting to make a left turn from 7<sup>th</sup> Street onto 99W.

The signalized intersection at 99W/5<sup>th</sup> Street meets the ODOT mobility target. Field observations, however, reveal long southbound queues leading up to this intersection in the p.m. peak hour, typically extending past the intersection of 1<sup>st</sup> Street. This results in vehicles often waiting through multiple cycles to advance through the 5<sup>th</sup> Street signal.



Additional operational issues upstream of the 5<sup>th</sup> Street intersection compound the driver's perception of queuing and delay, and disrupt flow to the intersection. The net effect is that the vehicle carrying capacity of this segment is less than the capacity at the 5<sup>th</sup> Street intersection, and forms a bottleneck, which restricts the traffic flow. This is an exception to the statement made previously about how intersection conditions dictate system performance. In this case, the measured congestion at 5<sup>th</sup> Street is an incomplete representation of highway conditions, because the number of vehicles arriving over the hour is constrained by the bottleneck effect. The operational issues in this segment include the following:

- About a quarter mile upstream from 5<sup>th</sup> Street, about 20 vehicles are able to take the eastbound left turn from 1<sup>st</sup> Street onto 99W northbound in the p.m. peak hour. This indicates that southbound traffic is not continuous, and gaps are available.
- About a half mile upstream from 5<sup>th</sup> Street, a significant number of vehicles (over 200 eastbound right and over 100 eastbound left) turn from Fox Farm Road onto southbound 99W in the p.m. peak hour. This indicates that either gaps are available, or traffic is taking turns. In a situation where there was a continuous stream of traffic on 99W, these turns would not be possible, as Fox Farm Road is stop-controlled.
- Less than a mile upstream of the 5<sup>th</sup> Street intersection, the two southbound lanes on 99W merge into a single lane. Vehicles must sort themselves into the single lane, which typically creates unstable flow at the bottleneck.



### Access Spacing

An access inventory was conducted along Highway 99W within Dundee, comparing the number of existing approaches (driveways and public streets) to the applicable ODOT spacing standard. Table 11 shows the number of existing approaches for each segment of 99W and compares it to the approximate number of driveway or public street approaches that would be allowed under full compliance with the spacing standards. As shown, all segments of 99W have more driveway and public street approaches than allowed under the standard, and the stretch of 99W from 7<sup>th</sup> Street to Niederberger Road is particularly dense with driveways. It is expected that, as properties along 99W are redeveloped, accesses will be removed or consolidated in order to move towards the standard.

**Table 11: Highway 99W Access Spacing Inventory**

Highway 99W Roadway Segment	Segment Length	Allowed Approaches*	West Side	East Side
Fox Farm Road to 1 <sup>st</sup> Street	1000	1	1	3
1 <sup>st</sup> Street to 3 <sup>rd</sup> Street	720	0	1	1
3 <sup>rd</sup> Street to 5 <sup>th</sup> Street	720	0	1	0
5 <sup>th</sup> Street to 7 <sup>th</sup> Street	720	0	0	1
7 <sup>th</sup> Street to 9 <sup>th</sup> Street	720	0	6	6
9 <sup>th</sup> Street to 11 <sup>th</sup> Street	720	0	5	4
11 <sup>th</sup> Street to Niederberger Road	1200	1	3	3

\* Segment length divided by 500-foot access spacing standard, minus existing local street approach

## Appendix

## Seasonal Factors

ODOT's Analysis Procedures Manual (APM) calls for adjustment of raw traffic counts to 30<sup>th</sup> highest hour volumes to account for seasonal variation through the course of a year. Counts used in this analysis were collected in early February 2011 (for the Newberg-Dundee Bypass Phase 1 project) and early February 2012. Under normal circumstances the ATR Characteristic method would not be used for 99W, since there are no existing ATR locations that have characteristics acceptably similar to those found in the study area. However, to maintain reasonable consistency with the Bypass work, the Dundee TSP Update analysis uses the same seasonal factoring approach for counts on Highway 99W. This is the ATR Characteristic method, using ATR 36-004 (near Highway 99W/Springbrook Road in Newberg, MP 21.81) and ATR 36-006 (approximately five miles southwest of McMinnville on Highway 18, MP 41.00). Both ATRs are assumed to have similar seasonal fluctuations as Highway 99W through Dundee.

Table 1: Seasonal Adjustment Factor Calculations for 99W



















	2005	2006	2007	2008	2009
<b>ATR 36-004 (99W/Springbrook, MP 21.81)</b>					
February	100	99	102	106	100
Peak Month	108	109	109	109	109
Average Month	101	102	103	105	102
Seasonal Adjustment Factor	$109/100.7 = 1.08$				
Average Adjustment Factor	$102.3/100.7 = 1.02$				
<b>ATR 36-006 (OR 18, MP 41.00)</b>					
February	92	92	90	95	90
Peak Month	108	106	110	109	110
Average Month	93	95	95	97	94
Seasonal Adjustment Factor	$109/91.3 = 1.19$				
Average Adjustment Factor	$95.7/91.3 = 1.05$				
99W Seasonal Adjustment Factor	$109/96 = 1.14$				
99W Average Adjustment Factor	$99/96 = 1.03$				

For raw traffic counts on Dundee's local street system, the Seasonal Trend method was used. The Commuter trend was selected, with a February/peak month growth factor of  $1.0/0.90 = 1.11$ , and a February/average month factor of  $1.0/0.95 = 1.05$ .

# HCM Unsignalized Intersection Capacity Analysis

## 1: NE Fox Farm Rd & 99W

3/15/2012

												
Movement	EBL	EBT	EBR	WBL	WBT	WBR	NBL	NBT	NBR	SBL	SBT	SBR
Lane Configurations												
Volume (veh/h)	10	5	215	125	5	2	20	990	55	2	940	5
Sign Control		Stop			Stop			Free			Free	
Grade		0%			0%			0%			0%	
Peak Hour Factor	0.96	0.96	0.96	0.96	0.96	0.96	0.96	0.96	0.96	0.96	0.96	0.96
Hourly flow rate (vph)	10	5	224	130	5	2	21	1031	57	2	979	5
Pedestrians												
Lane Width (ft)												
Walking Speed (ft/s)												
Percent Blockage												
Right turn flare (veh)												
Median type								TWLTL			None	
Median storage (veh)								2				
Upstream signal (ft)												
pX, platoon unblocked												
vC, conflicting volume	2061	2114	979	2311	2090	1060	984			1089		
vC1, stage 1 conf vol	983	983		1102	1102							
vC2, stage 2 conf vol	1078	1130		1210	989							
vCu, unblocked vol	2061	2114	979	2311	2090	1060	984			1089		
tC, single (s)	7.1	6.5	6.2	7.1	6.5	6.7	4.1			4.1		
tC, 2 stage (s)	6.1	5.5		6.1	5.5							
tF (s)	3.5	4.0	3.3	3.5	4.0	3.8	2.2			2.2		
p0 queue free %	95	97	27	0	97	99	97			100		
cM capacity (veh/h)	189	208	305	36	207	221	690			649		
<b>Direction, Lane #</b>	<b>EB 1</b>	<b>WB 1</b>	<b>NB 1</b>	<b>NB 2</b>	<b>SB 1</b>	<b>SB 2</b>						
Volume Total	240	138	21	1089	981	5						
Volume Left	10	130	21	0	2	0						
Volume Right	224	2	0	57	0	5						
cSH	294	38	690	1700	649	1700						
Volume to Capacity	0.81	3.64	0.03	0.64	0.00	0.00						
Queue Length 95th (ft)	167	Err	2	0	0	0						
Control Delay (s)	54.5	Err	10.4	0.0	0.1	0.0						
Lane LOS	F	F	B		A							
Approach Delay (s)	54.5	Err	0.2		0.1							
Approach LOS	F	F										
<b>Intersection Summary</b>												
Average Delay			561.4									
Intersection Capacity Utilization			86.9%		ICU Level of Service				E			
Analysis Period (min)			15									

# HCM Unsignalized Intersection Capacity Analysis

## 2: SW 1st St & 99W

3/15/2012



Movement	EBL	EBT	EBR	WBL	WBT	WBR	NBL	NBT	NBR	SBL	SBT	SBR
Lane Configurations		↔			↔		↗	↑		↖	↑	↗
Volume (veh/h)	20	0	10	5	0	45	15	1000	10	20	1155	105
Sign Control		Stop			Stop			Free			Free	
Grade		0%			0%			0%			0%	
Peak Hour Factor	0.97	0.97	0.97	0.97	0.97	0.97	0.97	0.97	0.97	0.97	0.97	0.97
Hourly flow rate (vph)	21	0	10	5	0	46	15	1031	10	21	1191	108
Pedestrians					2							
Lane Width (ft)					12.0							
Walking Speed (ft/s)					4.0							
Percent Blockage					0							
Right turn flare (veh)												
Median type							TWLTL			TWLTL		
Median storage veh							2			2		
Upstream signal (ft)												
pX, platoon unblocked												
vC, conflicting volume	2340	2306	1191	2311	2409	1038	1299			1043		
vC1, stage 1 conf vol	1232	1232		1069	1069							
vC2, stage 2 conf vol	1108	1074		1242	1340							
vCu, unblocked vol	2340	2306	1191	2311	2409	1038	1299			1043		
tC, single (s)	7.1	6.5	6.2	7.1	6.5	6.2	4.1			4.1		
tC, 2 stage (s)	6.1	5.5		6.1	5.5							
tF (s)	3.5	4.0	3.3	3.5	4.0	3.3	2.2			2.2		
p0 queue free %	85	100	96	96	100	83	97			97		
cM capacity (veh/h)	136	178	231	147	162	276	540			673		

Direction, Lane #	EB 1	WB 1	NB 1	NB 2	SB 1	SB 2	SB 3
Volume Total	31	52	15	1041	21	1191	108
Volume Left	21	5	15	0	21	0	0
Volume Right	10	46	0	10	0	0	108
cSH	157	254	540	1700	673	1700	1700
Volume to Capacity	0.20	0.20	0.03	0.61	0.03	0.70	0.06
Queue Length 95th (ft)	18	19	2	0	2	0	0
Control Delay (s)	33.4	22.8	11.9	0.0	10.5	0.0	0.0
Lane LOS	D	C	B		B		
Approach Delay (s)	33.4	22.8	0.2		0.2		
Approach LOS	D	C					

Intersection Summary			
Average Delay		1.1	
Intersection Capacity Utilization	74.7%		ICU Level of Service D
Analysis Period (min)		15	

# HCM Signalized Intersection Capacity Analysis

## 3: SW 5th St & 99W

3/15/2012



Movement	EBL	EBT	EBR	WBL	WBT	WBR	NBL	NBT	NBR	SBL	SBT	SBR
Lane Configurations												
Volume (vph)	55	10	10	15	5	40	10	930	10	75	1070	25
Ideal Flow (vphpl)	1900	1900	1900	1900	1900	1900	1900	1900	1900	1900	1900	1900
Total Lost time (s)	4.5	4.5			4.5		4.5	5.5		4.5	5.5	
Lane Util. Factor	1.00	1.00			1.00		1.00	1.00		1.00	1.00	
Frbp, ped/bikes	1.00	0.99			0.98		1.00	1.00		1.00	1.00	
Flpb, ped/bikes	1.00	1.00			1.00		1.00	1.00		1.00	1.00	
Frt	1.00	0.93			0.91		1.00	1.00		1.00	1.00	
Flt Protected	0.95	1.00			0.99		0.95	1.00		0.95	1.00	
Satd. Flow (prot)	1730	1736			1639		1805	1842		1736	1856	
Flt Permitted	0.49	1.00			0.91		0.12	1.00		0.95	1.00	
Satd. Flow (perm)	889	1736			1509		221	1842		1736	1856	
Peak-hour factor, PHF	0.98	0.98	0.98	0.98	0.98	0.98	0.98	0.98	0.98	0.98	0.98	0.98
Adj. Flow (vph)	56	10	10	15	5	41	10	949	10	77	1092	26
RTOR Reduction (vph)	0	8	0	0	38	0	0	0	0	0	0	0
Lane Group Flow (vph)	56	12	0	0	23	0	10	959	0	77	1118	0
Confl. Peds. (#/hr)	4		2	2		4	2					2
Heavy Vehicles (%)	4%	0%	0%	0%	0%	3%	0%	3%	0%	4%	2%	0%
Turn Type	pm+pt			Perm			pm+pt			custom		
Protected Phases	3	8			4		1	6		5	2	
Permitted Phases	8			4			6			5		
Actuated Green, G (s)	18.7	18.7			7.5		76.6	75.0		10.5	83.9	
Effective Green, g (s)	18.7	18.7			7.5		76.6	75.0		10.5	83.9	
Actuated g/C Ratio	0.16	0.16			0.06		0.65	0.63		0.09	0.71	
Clearance Time (s)	4.5	4.5			4.5		4.5	5.5		4.5	5.5	
Vehicle Extension (s)	2.5	2.5			2.5		2.5	5.0		2.5	5.0	
Lane Grp Cap (vph)	188	273			95		164	1164		154	1312	
v/s Ratio Prot	c0.02	0.01					0.00	0.52		c0.04	c0.60	
v/s Ratio Perm	c0.03				0.01		0.04					
v/c Ratio	0.30	0.04			0.24		0.06	0.82		0.50	0.85	
Uniform Delay, d1	43.8	42.4			52.9		15.3	16.8		51.6	12.8	
Progression Factor	1.00	1.00			1.00		1.00	1.00		1.00	1.00	
Incremental Delay, d2	0.6	0.0			0.9		0.1	5.4		1.9	6.1	
Delay (s)	44.4	42.5			53.8		15.4	22.2		53.5	18.9	
Level of Service	D	D			D		B	C		D	B	
Approach Delay (s)		43.9			53.8			22.1			21.1	
Approach LOS		D			D			C			C	

### Intersection Summary

HCM Average Control Delay	23.2	HCM Level of Service	C
HCM Volume to Capacity ratio	0.75		
Actuated Cycle Length (s)	118.7	Sum of lost time (s)	14.5
Intersection Capacity Utilization	82.6%	ICU Level of Service	E
Analysis Period (min)	15		
c Critical Lane Group			



# HCM Unsignalized Intersection Capacity Analysis

## 4: SW 7th St & 99W

3/15/2012



Movement	EBL	EBR	NBL	NBT	SBT	SBR
Lane Configurations						
Volume (veh/h)	15	15	20	935	1070	25
Sign Control	Stop			Free	Free	
Grade	0%			0%	0%	
Peak Hour Factor	0.91	0.91	0.91	0.91	0.91	0.91
Hourly flow rate (vph)	16	16	22	1027	1176	27
Pedestrians						
Lane Width (ft)						
Walking Speed (ft/s)						
Percent Blockage						
Right turn flare (veh)						
Median type				TWLTL	TWLTL	
Median storage veh				2	2	
Upstream signal (ft)					717	
pX, platoon unblocked	0.32	0.32	0.32			
vC, conflicting volume	2261	1190	1203			
vC1, stage 1 conf vol	1190					
vC2, stage 2 conf vol	1071					
vCu, unblocked vol	3877	530	573			
tC, single (s)	6.4	6.2	4.1			
tC, 2 stage (s)	5.4					
tF (s)	3.5	3.3	2.2			
p0 queue free %	89	91	93			
cM capacity (veh/h)	150	176	320			

Direction, Lane #	EB 1	NB 1	NB 2	SB 1
Volume Total	33	22	1027	1203
Volume Left	16	22	0	0
Volume Right	16	0	0	27
cSH	162	320	1700	1700
Volume to Capacity	0.20	0.07	0.60	0.71
Queue Length 95th (ft)	18	5	0	0
Control Delay (s)	32.9	17.1	0.0	0.0
Lane LOS	D	C		
Approach Delay (s)	32.9	0.4		0.0
Approach LOS	D			

Intersection Summary			
Average Delay		0.6	
Intersection Capacity Utilization	67.8%		ICU Level of Service C
Analysis Period (min)	15		

# HCM Unsignalized Intersection Capacity Analysis

## 5: SW 9th St & 99W

3/15/2012



Movement	EBL	EBT	EBR	WBL	WBT	WBR	NBL	NBT	NBR	SBL	SBT	SBR
Lane Configurations		↕			↕		↗	↘		↗	↘	
Volume (veh/h)	30	0	20	0	0	0	30	925	0	2	1030	55
Sign Control		Stop			Stop			Free			Free	
Grade		0%			0%			0%			0%	
Peak Hour Factor	0.91	0.91	0.91	0.91	0.91	0.91	0.91	0.91	0.91	0.91	0.91	0.91
Hourly flow rate (vph)	33	0	22	0	0	0	33	1016	0	2	1132	60
Pedestrians												
Lane Width (ft)												
Walking Speed (ft/s)												
Percent Blockage												
Right turn flare (veh)												
Median type							TWLTL			TWLTL		
Median storage (veh)							2			2		
Upstream signal (ft)												
pX, platoon unblocked												
vC, conflicting volume	2249	2249	1162	2241	2279	1016	1192			1016		
vC1, stage 1 conf vol	1166	1166		1082	1082							
vC2, stage 2 conf vol	1082	1082		1158	1197							
vCu, unblocked vol	2249	2249	1162	2241	2279	1016	1192			1016		
tC, single (s)	7.1	6.5	6.2	7.1	6.5	6.2	4.1			4.1		
tC, 2 stage (s)	6.1	5.5		6.1	5.5							
tF (s)	3.5	4.0	3.3	3.5	4.0	3.3	2.2			2.2		
p0 queue free %	80	100	91	100	100	100	94			100		
cM capacity (veh/h)	166	189	237	144	173	289	585			682		

Direction, Lane #	EB 1	WB 1	NB 1	NB 2	SB 1	SB 2
Volume Total	55	0	33	1016	2	1192
Volume Left	33	0	33	0	2	0
Volume Right	22	0	0	0	0	60
cSH	189	1700	585	1700	682	1700
Volume to Capacity	0.29	0.00	0.06	0.60	0.00	0.70
Queue Length 95th (ft)	29	0	4	0	0	0
Control Delay (s)	31.8	0.0	11.5	0.0	10.3	0.0
Lane LOS	D	A	B		B	
Approach Delay (s)	31.8	0.0	0.4		0.0	
Approach LOS	D	A				

### Intersection Summary

Average Delay	0.9
Intersection Capacity Utilization	67.5%
ICU Level of Service	C
Analysis Period (min)	15

# HCM Unsignalized Intersection Capacity Analysis

## 6: SW 10th St & 99W

3/15/2012



Movement	EBL	EBT	EBR	WBL	WBT	WBR	NBL	NBT	NBR	SBL	SBT	SBR
Lane Configurations		↔			↔		↗	↘		↗	↘	
Volume (veh/h)	2	0	2	15	0	20	2	935	20	50	1000	0
Sign Control		Stop			Stop			Free			Free	
Grade		0%			0%			0%			0%	
Peak Hour Factor	0.93	0.93	0.93	0.93	0.93	0.93	0.93	0.93	0.93	0.93	0.93	0.93
Hourly flow rate (vph)	2	0	2	16	0	22	2	1005	22	54	1075	0
Pedestrians		6			2							10
Lane Width (ft)		12.0			12.0						12.0	
Walking Speed (ft/s)		4.0			4.0						4.0	
Percent Blockage		1			0						1	
Right turn flare (veh)												
Median type							TWLTL			TWLTL		
Median storage (veh)							2			2		
Upstream signal (ft)												
pX, platoon unblocked												
vC, conflicting volume	2230	2222	1081	2207	2211	1028	1081			1029		
vC1, stage 1 conf vol	1189	1189		1022	1022							
vC2, stage 2 conf vol	1041	1033		1185	1189							
vCu, unblocked vol	2230	2222	1081	2207	2211	1028	1081			1029		
tC, single (s)	7.6	6.5	6.2	7.1	6.5	6.4	4.1			4.2		
tC, 2 stage (s)	6.6	5.5		6.1	5.5							
tF (s)	4.0	4.0	3.3	3.5	4.0	3.5	2.2			2.3		
p0 queue free %	98	100	99	90	100	92	100			92		
cM capacity (veh/h)	110	175	266	165	188	263	649			659		

Direction, Lane #	EB 1	WB 1	NB 1	NB 2	SB 1	SB 2
Volume Total	4	38	2	1027	54	1075
Volume Left	2	16	2	0	54	0
Volume Right	2	22	0	22	0	0
cSH	156	210	649	1700	659	1700
Volume to Capacity	0.03	0.18	0.00	0.60	0.08	0.63
Queue Length 95th (ft)	2	16	0	0	7	0
Control Delay (s)	28.8	25.9	10.6	0.0	11.0	0.0
Lane LOS	D	D	B		B	
Approach Delay (s)	28.8	25.9	0.0		0.5	
Approach LOS	D	D				

Intersection Summary		
Average Delay		0.8
Intersection Capacity Utilization	65.5%	ICU Level of Service C
Analysis Period (min)		15

# HCM Unsignalized Intersection Capacity Analysis

## 7: SW Niederberger Dr & 99W

3/15/2012



Movement	EBL	EBT	EBR	WBL	WBT	WBR	NBL	NBT	NBR	SBL	SBT	SBR
Lane Configurations		↕			↕		↗	↘		↗	↘	
Volume (veh/h)	10	0	15	0	0	5	20	940	10	10	980	25
Sign Control		Stop			Stop			Free			Free	
Grade		0%			0%			0%			0%	
Peak Hour Factor	0.91	0.91	0.91	0.91	0.91	0.91	0.91	0.91	0.91	0.91	0.91	0.91
Hourly flow rate (vph)	11	0	16	0	0	5	22	1033	11	11	1077	27
Pedestrians												
Lane Width (ft)												
Walking Speed (ft/s)												
Percent Blockage												
Right turn flare (veh)												
Median type								None			TWLTL	
Median storage (veh)												2
Upstream signal (ft)												
pX, platoon unblocked												
vC, conflicting volume	2195	2201	1091	2198	2209	1038	1104			1044		
vC1, stage 1 conf vol	1113	1113		1082	1082							
vC2, stage 2 conf vol	1082	1088		1115	1126							
vCu, unblocked vol	2195	2201	1091	2198	2209	1038	1104			1044		
tC, single (s)	7.2	6.5	6.2	7.1	6.5	6.7	4.1			4.1		
tC, 2 stage (s)	6.2	5.5		6.1	5.5							
tF (s)	3.6	4.0	3.3	3.5	4.0	3.8	2.2			2.2		
p0 queue free %	93	100	94	100	100	98	97			98		
cM capacity (veh/h)	161	195	264	160	189	227	640			674		

















Direction, Lane #	EB 1	WB 1	NB 1	NB 2	SB 1	SB 2
Volume Total	27	5	22	1044	11	1104
Volume Left	11	0	22	0	11	0
Volume Right	16	5	0	11	0	27
cSH	210	227	640	1700	674	1700
Volume to Capacity	0.13	0.02	0.03	0.61	0.02	0.65
Queue Length 95th (ft)	11	2	3	0	1	0
Control Delay (s)	24.7	21.2	10.8	0.0	10.4	0.0
Lane LOS	C	C	B		B	
Approach Delay (s)	24.7	21.2	0.2		0.1	
Approach LOS	C	C				

Intersection Summary		
Average Delay		0.5
Intersection Capacity Utilization	67.9%	ICU Level of Service
Analysis Period (min)		15
		C

# HCM Unsignalized Intersection Capacity Analysis

## 8: SW Upland Dr & SW Alder St

3/15/2012

												
Movement	EBL	EBT	EBR	WBL	WBT	WBR	NBL	NBT	NBR	SBL	SBT	SBR
Lane Configurations												
Sign Control		Stop			Stop			Stop			Stop	
Volume (vph)	2	5	5	25	15	10	5	5	55	5	5	0
Peak Hour Factor	0.88	0.88	0.88	0.88	0.88	0.88	0.88	0.88	0.88	0.88	0.88	0.88
Hourly flow rate (vph)	2	6	6	28	17	11	6	6	62	6	6	0
Direction, Lane #	EB 1	WB 1	NB 1	SB 1								
Volume Total (vph)	14	57	74	11								
Volume Left (vph)	2	28	6	6								
Volume Right (vph)	6	11	63	0								
Hadj (s)	-0.18	0.01	-0.46	0.13								
Departure Headway (s)	3.9	4.1	3.6	4.2								
Degree Utilization, x	0.01	0.06	0.07	0.01								
Capacity (veh/h)	886	857	968	826								
Control Delay (s)	7.0	7.4	6.9	7.3								
Approach Delay (s)	7.0	7.4	6.9	7.3								
Approach LOS	A	A	A	A								
Intersection Summary												
Delay			7.1									
HCM Level of Service			A									
Intersection Capacity Utilization			17.3%	ICU Level of Service	A							
Analysis Period (min)			15									

HCM Unsignalized Intersection Capacity Analysis  
 9: SW 9th St & SW Alder St

3/15/2012



Movement	EBL	EBT	EBR	WBL	WBT	WBR	NBL	NBT	NBR	SBL	SBT	SBR
Lane Configurations		↕			↕			↕			↕	
Volume (veh/h)	20	50	5	10	60	15	5	20	5	5	5	15
Sign Control		Free			Free			Stop			Stop	
Grade		0%			0%			0%			0%	
Peak Hour Factor	0.82	0.82	0.82	0.82	0.82	0.82	0.82	0.82	0.82	0.82	0.82	0.82
Hourly flow rate (vph)	24	61	6	12	73	18	6	24	6	6	6	18
Pedestrians												
Lane Width (ft)												
Walking Speed (ft/s)												
Percent Blockage												
Right turn flare (veh)												
Median type		None			None							
Median storage (veh)												
Upstream signal (ft)												
pX, platoon unblocked												
vC, conflicting volume	91			67			241	229	64	238	223	82
vC1, stage 1 conf vol												
vC2, stage 2 conf vol												
vCu, unblocked vol	91			67			241	229	64	238	223	82
tC, single (s)	4.1			4.1			7.1	6.5	6.2	7.1	6.5	6.2
tC, 2 stage (s)												
tF (s)	2.2			2.2			3.5	4.0	3.3	3.5	4.0	3.3
p0 queue free %	98			99			99	96	99	99	99	98
cM capacity (veh/h)	1503			1534			682	655	1000	679	660	977

Direction, Lane #	EB 1	WB 1	NB 1	SB 1
Volume Total	91	104	37	30
Volume Left	24	12	6	6
Volume Right	6	18	6	18
cSH	1503	1534	700	825
Volume to Capacity	0.02	0.01	0.05	0.04
Queue Length 95th (ft)	1	1	4	3
Control Delay (s)	2.1	0.9	10.4	9.5
Lane LOS	A	A	B	A
Approach Delay (s)	2.1	0.9	10.4	9.5
Approach LOS			B	A

Intersection Summary			
Average Delay		3.7	
Intersection Capacity Utilization	17.6%		ICU Level of Service
Analysis Period (min)		15	A



# HCM Unsignalized Intersection Capacity Analysis

## 10: SW 5th St & SE Edwards Dr

3/15/2012



Movement	EBL	EBR	NBL	NBT	SBT	SBR
Lane Configurations						
Volume (veh/h)	2	45	35	5	2	5
Sign Control	Stop			Free	Free	
Grade	0%			0%	0%	
Peak Hour Factor	0.86	0.86	0.86	0.86	0.86	0.86
Hourly flow rate (vph)	2	52	41	6	2	6
Pedestrians						
Lane Width (ft)						
Walking Speed (ft/s)						
Percent Blockage						
Right turn flare (veh)						
Median type				None	None	
Median storage (veh)						
Upstream signal (ft)						
pX, platoon unblocked						
vC, conflicting volume	92	5	8			
vC1, stage 1 conf vol						
vC2, stage 2 conf vol						
vCu, unblocked vol	92	5	8			
tC, single (s)	6.4	6.2	4.1			
tC, 2 stage (s)						
tF (s)	3.5	3.3	2.2			
p0 queue free %	100	95	97			
cM capacity (veh/h)	885	1078	1612			
<b>Direction, Lane #</b>	<b>EB 1</b>	<b>NB 1</b>	<b>SB 1</b>			
Volume Total	55	47	8			
Volume Left	2	41	0			
Volume Right	52	0	6			
cSH	1068	1612	1700			
Volume to Capacity	0.05	0.03	0.00			
Queue Length 95th (ft)	4	2	0			
Control Delay (s)	8.6	6.4	0.0			
Lane LOS	A	A				
Approach Delay (s)	8.6	6.4	0.0			
Approach LOS	A					
<b>Intersection Summary</b>						
Average Delay			7.0			
Intersection Capacity Utilization		18.9%		ICU Level of Service		A
Analysis Period (min)			15			

# HCM Unsignalized Intersection Capacity Analysis

## 11: SE Parks Dr & SE Edwards Dr

3/15/2012





















Movement	EBL	EBR	NBL	NBT	SBT	SBR
Lane Configurations						
Volume (veh/h)	15	2	0	5	5	5
Sign Control	Stop			Free	Free	
Grade	0%			0%	0%	
Peak Hour Factor	0.73	0.73	0.73	0.73	0.73	0.73
Hourly flow rate (vph)	21	3	0	7	7	7
Pedestrians						
Lane Width (ft)						
Walking Speed (ft/s)						
Percent Blockage						
Right turn flare (veh)						
Median type				None	None	
Median storage (veh)						
Upstream signal (ft)						
pX, platoon unblocked						
vC, conflicting volume	17	10	14			
vC1, stage 1 conf vol						
vC2, stage 2 conf vol						
vCu, unblocked vol	17	10	14			
tC, single (s)	6.4	6.2	4.1			
tC, 2 stage (s)						
tF (s)	3.5	3.3	2.2			
p0 queue free %	98	100	100			
cM capacity (veh/h)	1001	1071	1605			
<b>Direction, Lane #</b>	<b>EB 1</b>	<b>NB 1</b>	<b>SB 1</b>			
Volume Total	23	7	14			
Volume Left	21	0	0			
Volume Right	3	0	7			
cSH	1009	1605	1700			
Volume to Capacity	0.02	0.00	0.01			
Queue Length 95th (ft)	2	0	0			
Control Delay (s)	8.7	0.0	0.0			
Lane LOS	A					
Approach Delay (s)	8.7	0.0	0.0			
Approach LOS	A					
<b>Intersection Summary</b>						
Average Delay			4.6			
Intersection Capacity Utilization		13.3%		ICU Level of Service		A
Analysis Period (min)			15			

# HCM Unsignalized Intersection Capacity Analysis

## 1: NE Fox Farm Rd & 99W

3/15/2012

												
Movement	EBL	EBT	EBR	WBL	WBT	WBR	NBL	NBT	NBR	SBL	SBT	SBR
Lane Configurations												
Volume (veh/h)	10	5	230	135	5	2	20	1060	55	2	1000	5
Sign Control		Stop			Stop			Free			Free	
Grade		0%			0%			0%			0%	
Peak Hour Factor	0.96	0.96	0.96	0.96	0.96	0.96	0.96	0.96	0.96	0.96	0.96	0.96
Hourly flow rate (vph)	10	5	240	141	5	2	21	1104	57	2	1042	5
Pedestrians												
Lane Width (ft)												
Walking Speed (ft/s)												
Percent Blockage												
Right turn flare (veh)												
Median type								TWLTL				None
Median storage (veh)								2				
Upstream signal (ft)												
pX, platoon unblocked												
vC, conflicting volume	2196	2249	1042	2462	2226	1133	1047			1161		
vC1, stage 1 conf vol	1046	1046		1174	1174							
vC2, stage 2 conf vol	1151	1203		1288	1051							
vCu, unblocked vol	2196	2249	1042	2462	2226	1133	1047			1161		
tC, single (s)	7.1	6.5	6.2	7.1	6.5	6.7	4.1			4.1		
tC, 2 stage (s)	6.1	5.5		6.1	5.5							
tF (s)	3.5	4.0	3.3	3.5	4.0	3.8	2.2			2.2		
p0 queue free %	94	97	15	0	97	99	97			100		
cM capacity (veh/h)	171	191	280	8	190	199	653			609		
<b>Direction, Lane #</b>	<b>EB 1</b>	<b>WB 1</b>	<b>NB 1</b>	<b>NB 2</b>	<b>SB 1</b>	<b>SB 2</b>						
Volume Total	255	148	21	1161	1044	5						
Volume Left	10	141	21	0	2	0						
Volume Right	240	2	0	57	0	5						
cSH	271	8	653	1700	609	1700						
Volume to Capacity	0.94	18.07	0.03	0.68	0.00	0.00						
Queue Length 95th (ft)	222	Err	2	0	0	0						
Control Delay (s)	81.6	Err	10.7	0.0	0.1	0.0						
Lane LOS	F	F	B		A							
Approach Delay (s)	81.6	Err	0.2		0.1							
Approach LOS	F	F										
<b>Intersection Summary</b>												
Average Delay			569.5									
Intersection Capacity Utilization			92.0%		ICU Level of Service				F			
Analysis Period (min)			15									

# HCM Unsignalized Intersection Capacity Analysis

## 2: SW 1st St & 99W

3/15/2012



Movement	EBL	EBT	EBR	WBL	WBT	WBR	NBL	NBT	NBR	SBL	SBT	SBR
Lane Configurations		↔			↔		↗	↑		↖	↑	↗
Volume (veh/h)	20	0	10	10	0	45	15	1070	10	25	1230	110
Sign Control		Stop			Stop			Free			Free	
Grade		0%			0%			0%			0%	
Peak Hour Factor	0.97	0.97	0.97	0.97	0.97	0.97	0.97	0.97	0.97	0.97	0.97	0.97
Hourly flow rate (vph)	21	0	10	10	0	46	15	1103	10	26	1268	113
Pedestrians					2							
Lane Width (ft)					12.0							
Walking Speed (ft/s)					4.0							
Percent Blockage					0							
Right turn flare (veh)												
Median type								TWLTL			TWLTL	
Median storage veh								2			2	
Upstream signal (ft)												
pX, platoon unblocked												
vC, conflicting volume	2500	2466	1268	2471	2574	1110	1381			1115		
vC1, stage 1 conf vol	1320	1320		1141	1141							
vC2, stage 2 conf vol	1180	1146		1330	1433							
vCu, unblocked vol	2500	2466	1268	2471	2574	1110	1381			1115		
tC, single (s)	7.1	6.5	6.2	7.1	6.5	6.2	4.1			4.1		
tC, 2 stage (s)	6.1	5.5		6.1	5.5							
tF (s)	3.5	4.0	3.3	3.5	4.0	3.3	2.2			2.2		
p0 queue free %	82	100	95	92	100	81	97			96		
cM capacity (veh/h)	117	159	208	128	144	251	502			633		

Direction, Lane #	EB 1	WB 1	NB 1	NB 2	SB 1	SB 2	SB 3
Volume Total	31	57	15	1113	26	1268	113
Volume Left	21	10	15	0	26	0	0
Volume Right	10	46	0	10	0	0	113
cSH	137	214	502	1700	633	1700	1700
Volume to Capacity	0.23	0.27	0.03	0.65	0.04	0.75	0.07
Queue Length 95th (ft)	21	26	2	0	3	0	0
Control Delay (s)	38.9	27.8	12.4	0.0	10.9	0.0	0.0
Lane LOS	E	D	B		B		
Approach Delay (s)	38.9	27.8	0.2		0.2		
Approach LOS	E	D					

Intersection Summary			
Average Delay		1.2	
Intersection Capacity Utilization	76.3%	ICU Level of Service	D
Analysis Period (min)	15		

# HCM Signalized Intersection Capacity Analysis

## 3: SW 5th St & 99W

3/15/2012



Movement	EBL	EBT	EBR	WBL	WBT	WBR	NBL	NBT	NBR	SBL	SBT	SBR
Lane Configurations												
Volume (vph)	60	10	10	15	5	40	10	995	10	80	1140	30
Ideal Flow (vphpl)	1900	1900	1900	1900	1900	1900	1900	1900	1900	1900	1900	1900
Total Lost time (s)	4.5	4.5			4.5		4.5	5.5		4.5	5.5	
Lane Util. Factor	1.00	1.00			1.00		1.00	1.00		1.00	1.00	
Frbp, ped/bikes	1.00	0.99			0.98		1.00	1.00		1.00	1.00	
Flpb, ped/bikes	1.00	1.00			1.00		1.00	1.00		1.00	1.00	
Frt	1.00	0.93			0.91		1.00	1.00		1.00	1.00	
Flt Protected	0.95	1.00			0.99		0.95	1.00		0.95	1.00	
Satd. Flow (prot)	1730	1735			1637		1805	1842		1736	1855	
Flt Permitted	0.46	1.00			0.91		0.09	1.00		0.14	1.00	
Satd. Flow (perm)	831	1735			1507		176	1842		253	1855	
Peak-hour factor, PHF	0.98	0.98	0.98	0.98	0.98	0.98	0.98	0.98	0.98	0.98	0.98	0.98
Adj. Flow (vph)	61	10	10	15	5	41	10	1015	10	82	1163	31
RTOR Reduction (vph)	0	9	0	0	39	0	0	0	0	0	1	0
Lane Group Flow (vph)	61	11	0	0	22	0	10	1025	0	82	1193	0
Confl. Peds. (#/hr)	4		2	2		4	2					2
Heavy Vehicles (%)	4%	0%	0%	0%	0%	3%	0%	3%	0%	4%	2%	0%
Turn Type	pm+pt			Perm			pm+pt			pm+pt		
Protected Phases	3	8			4		1	6		5	2	
Permitted Phases	8			4			6			2		
Actuated Green, G (s)	20.3	20.3			8.3		99.8	97.9		109.4	103.0	
Effective Green, g (s)	20.3	20.3			8.3		99.8	97.9		109.4	103.0	
Actuated g/C Ratio	0.15	0.15			0.06		0.71	0.70		0.78	0.74	
Clearance Time (s)	4.5	4.5			4.5		4.5	5.5		4.5	5.5	
Vehicle Extension (s)	2.5	2.5			2.5		2.5	5.0		2.5	5.0	
Lane Grp Cap (vph)	169	252			90		148	1291		272	1368	
v/s Ratio Prot	c0.02	0.01					0.00	0.56		c0.02	c0.64	
v/s Ratio Perm	c0.03				0.01		0.05			0.22		
v/c Ratio	0.36	0.05			0.25		0.07	0.79		0.30	0.87	
Uniform Delay, d1	53.2	51.4			62.7		19.7	14.1		15.9	13.5	
Progression Factor	1.00	1.00			1.00		1.00	1.00		1.00	1.00	
Incremental Delay, d2	1.0	0.1			1.1		0.1	4.0		0.5	6.9	
Delay (s)	54.1	51.4			63.8		19.8	18.1		16.4	20.4	
Level of Service	D	D			E		B	B		B	C	
Approach Delay (s)		53.5			63.8			18.1			20.2	
Approach LOS		D			E			B			C	

### Intersection Summary

HCM Average Control Delay	21.5	HCM Level of Service	C
HCM Volume to Capacity ratio	0.78		
Actuated Cycle Length (s)	139.7	Sum of lost time (s)	14.5
Intersection Capacity Utilization	86.7%	ICU Level of Service	E
Analysis Period (min)	15		
c Critical Lane Group			

# HCM Unsignalized Intersection Capacity Analysis

## 4: SW 7th St & 99W

3/15/2012



Movement	EBL	EBR	NBL	NBT	SBT	SBR
Lane Configurations						
Volume (veh/h)	15	15	20	1000	1140	25
Sign Control	Stop			Free	Free	
Grade	0%			0%	0%	
Peak Hour Factor	0.91	0.91	0.91	0.91	0.91	0.91
Hourly flow rate (vph)	16	16	22	1099	1253	27
Pedestrians						
Lane Width (ft)						
Walking Speed (ft/s)						
Percent Blockage						
Right turn flare (veh)						
Median type				TWLTL	TWLTL	
Median storage veh				2	2	
Upstream signal (ft)					717	
pX, platoon unblocked	0.28	0.28	0.28			
vC, conflicting volume	2409	1266	1280			
vC1, stage 1 conf vol	1266					
vC2, stage 2 conf vol	1143					
vCu, unblocked vol	4705	677	725			
tC, single (s)	6.4	6.2	4.1			
tC, 2 stage (s)	5.4					
tF (s)	3.5	3.3	2.2			
p0 queue free %	86	87	91			
cM capacity (veh/h)	119	128	249			

Direction, Lane #	EB 1	NB 1	NB 2	SB 1
Volume Total	33	22	1099	1280
Volume Left	16	22	0	0
Volume Right	16	0	0	27
cSH	124	249	1700	1700
Volume to Capacity	0.27	0.09	0.65	0.75
Queue Length 95th (ft)	25	7	0	0
Control Delay (s)	44.4	20.9	0.0	0.0
Lane LOS	E	C		
Approach Delay (s)	44.4	0.4		0.0
Approach LOS	E			



















Intersection Summary			
Average Delay		0.8	
Intersection Capacity Utilization		71.5%	ICU Level of Service C
Analysis Period (min)		15	



# HCM Unsignalized Intersection Capacity Analysis

## 5: SW 9th St & 99W

3/15/2012

												
Movement	EBL	EBT	EBR	WBL	WBT	WBR	NBL	NBT	NBR	SBL	SBT	SBR
Lane Configurations												
Volume (veh/h)	30	0	20	0	0	0	35	990	0	2	1095	60
Sign Control		Stop			Stop			Free			Free	
Grade		0%			0%			0%			0%	
Peak Hour Factor	0.91	0.91	0.91	0.91	0.91	0.91	0.91	0.91	0.91	0.91	0.91	0.91
Hourly flow rate (vph)	33	0	22	0	0	0	38	1088	0	2	1203	66
Pedestrians												
Lane Width (ft)												
Walking Speed (ft/s)												
Percent Blockage												
Right turn flare (veh)												
Median type							TWLTL			TWLTL		
Median storage (veh)							2			2		
Upstream signal (ft)												
pX, platoon unblocked												
vC, conflicting volume	2405	2405	1236	2395	2438	1088	1269			1088		
vC1, stage 1 conf vol	1241	1241		1165	1165							
vC2, stage 2 conf vol	1165	1165		1230	1274							
vCu, unblocked vol	2405	2405	1236	2395	2438	1088	1269			1088		
tC, single (s)	7.1	6.5	6.2	7.1	6.5	6.2	4.1			4.1		
tC, 2 stage (s)	6.1	5.5		6.1	5.5							
tF (s)	3.5	4.0	3.3	3.5	4.0	3.3	2.2			2.2		
p0 queue free %	78	100	90	100	100	100	93			100		
cM capacity (veh/h)	147	171	215	124	153	262	547			641		
Direction, Lane #	EB 1	WB 1	NB 1	NB 2	SB 1	SB 2						
Volume Total	55	0	38	1088	2	1269						
Volume Left	33	0	38	0	2	0						
Volume Right	22	0	0	0	0	66						
cSH	169	1700	547	1700	641	1700						
Volume to Capacity	0.33	0.00	0.07	0.64	0.00	0.75						
Queue Length 95th (ft)	33	0	6	0	0	0						
Control Delay (s)	36.4	0.0	12.1	0.0	10.6	0.0						
Lane LOS	E	A	B		B							
Approach Delay (s)	36.4	0.0	0.4		0.0							
Approach LOS	E	A										
Intersection Summary												
Average Delay			1.0									
Intersection Capacity Utilization			71.3%	ICU Level of Service	C							
Analysis Period (min)			15									

# HCM Unsignalized Intersection Capacity Analysis

## 6: SW 10th St & 99W

3/15/2012



Movement	EBL	EBT	EBR	WBL	WBT	WBR	NBL	NBT	NBR	SBL	SBT	SBR
Lane Configurations		↕			↕		↗	↘		↗	↘	
Volume (veh/h)	2	0	2	15	0	20	2	1005	20	55	1060	0
Sign Control		Stop			Stop			Free			Free	
Grade		0%			0%			0%			0%	
Peak Hour Factor	0.93	0.93	0.93	0.93	0.93	0.93	0.93	0.93	0.93	0.93	0.93	0.93
Hourly flow rate (vph)	2	0	2	16	0	22	2	1081	22	59	1140	0
Pedestrians		6			2							10
Lane Width (ft)		12.0			12.0						12.0	
Walking Speed (ft/s)		4.0			4.0						4.0	
Percent Blockage		1			0						1	
Right turn flare (veh)												
Median type								TWLTL			TWLTL	
Median storage (veh)								2			2	
Upstream signal (ft)												
pX, platoon unblocked												
vC, conflicting volume	2381	2373	1146	2358	2362	1103	1146			1104		
vC1, stage 1 conf vol	1264	1264		1098	1098							
vC2, stage 2 conf vol	1116	1108		1260	1264							
vCu, unblocked vol	2381	2373	1146	2358	2362	1103	1146			1104		
tC, single (s)	7.6	6.5	6.2	7.1	6.5	6.4	4.1			4.2		
tC, 2 stage (s)	6.6	5.5		6.1	5.5							
tF (s)	4.0	4.0	3.3	3.5	4.0	3.5	2.2			2.3		
p0 queue free %	98	100	99	89	100	91	100			90		
cM capacity (veh/h)	92	155	244	147	170	237	614			617		



















Direction, Lane #	EB 1	WB 1	NB 1	NB 2	SB 1	SB 2
Volume Total	4	38	2	1102	59	1140
Volume Left	2	16	2	0	59	0
Volume Right	2	22	0	22	0	0
cSH	134	188	614	1700	617	1700
Volume to Capacity	0.03	0.20	0.00	0.65	0.10	0.67
Queue Length 95th (ft)	2	18	0	0	8	0
Control Delay (s)	32.7	28.9	10.9	0.0	11.5	0.0
Lane LOS	D	D	B		B	
Approach Delay (s)	32.7	28.9	0.0		0.6	
Approach LOS	D	D				

### Intersection Summary

Average Delay	0.8
Intersection Capacity Utilization	68.6%
ICU Level of Service	C
Analysis Period (min)	15

HCM Unsignalized Intersection Capacity Analysis  
 7: SW Niederberger Dr & 99W

3/15/2012

												
Movement	EBL	EBT	EBR	WBL	WBT	WBR	NBL	NBT	NBR	SBL	SBT	SBR
Lane Configurations												
Volume (veh/h)	10	0	20	0	0	5	20	1010	10	10	1040	25
Sign Control		Stop			Stop			Free				Free
Grade		0%			0%			0%				0%
Peak Hour Factor	0.91	0.91	0.91	0.91	0.91	0.91	0.91	0.91	0.91	0.91	0.91	0.91
Hourly flow rate (vph)	11	0	22	0	0	5	22	1110	11	11	1143	27
Pedestrians												
Lane Width (ft)												
Walking Speed (ft/s)												
Percent Blockage												
Right turn flare (veh)												
Median type								None			TWLTL	
Median storage (veh)												2
Upstream signal (ft)												
pX, platoon unblocked												
vC, conflicting volume	2338	2343	1157	2346	2352	1115	1170			1121		
vC1, stage 1 conf vol	1179	1179		1159	1159							
vC2, stage 2 conf vol	1159	1165		1187	1192							
vCu, unblocked vol	2338	2343	1157	2346	2352	1115	1170			1121		
tC, single (s)	7.2	6.5	6.2	7.1	6.5	6.7	4.1			4.1		
tC, 2 stage (s)	6.2	5.5		6.1	5.5							
tF (s)	3.6	4.0	3.3	3.5	4.0	3.8	2.2			2.2		
p0 queue free %	92	100	91	100	100	97	96			98		
cM capacity (veh/h)	144	178	241	140	173	204	604			631		
<b>Direction, Lane #</b>	<b>EB 1</b>	<b>WB 1</b>	<b>NB 1</b>	<b>NB 2</b>	<b>SB 1</b>	<b>SB 2</b>						
Volume Total	33	5	22	1121	11	1170						
Volume Left	11	0	22	0	11	0						
Volume Right	22	5	0	11	0	27						
cSH	197	204	604	1700	631	1700						
Volume to Capacity	0.17	0.03	0.04	0.66	0.02	0.69						
Queue Length 95th (ft)	15	2	3	0	1	0						
Control Delay (s)	26.9	23.2	11.2	0.0	10.8	0.0						
Lane LOS	D	C	B		B							
Approach Delay (s)	26.9	23.2	0.2		0.1							
Approach LOS	D	C										
<b>Intersection Summary</b>												
Average Delay			0.6									
Intersection Capacity Utilization			71.4%		ICU Level of Service					C		
Analysis Period (min)			15									

# HCM Unsignalized Intersection Capacity Analysis

## 8: SW Upland Dr & SW Alder St

3/15/2012



Movement	EBL	EBT	EBR	WBL	WBT	WBR	NBL	NBT	NBR	SBL	SBT	SBR
Lane Configurations		↕			↕			↕			↕	
Sign Control		Stop			Stop			Stop			Stop	
Volume (vph)	2	10	5	30	20	10	10	5	55	10	5	0
Peak Hour Factor	0.88	0.88	0.88	0.88	0.88	0.88	0.88	0.88	0.88	0.88	0.88	0.88
Hourly flow rate (vph)	2	11	6	34	23	11	11	6	62	11	6	0
Direction, Lane #	EB 1	WB 1	NB 1	SB 1								
Volume Total (vph)	19	68	80	17								
Volume Left (vph)	2	34	11	11								
Volume Right (vph)	6	11	63	0								
Hadj (s)	-0.12	0.03	-0.41	0.17								
Departure Headway (s)	4.0	4.1	3.7	4.3								
Degree Utilization, x	0.02	0.08	0.08	0.02								
Capacity (veh/h)	861	845	940	808								
Control Delay (s)	7.1	7.5	7.0	7.4								
Approach Delay (s)	7.1	7.5	7.0	7.4								
Approach LOS	A	A	A	A								
Intersection Summary												
Delay			7.3									
HCM Level of Service			A									
Intersection Capacity Utilization			20.6%	ICU Level of Service	A							
Analysis Period (min)			15									

# HCM Unsignalized Intersection Capacity Analysis

## 9: SW 9th St & SW Alder St

3/15/2012



Movement	EBL	EBT	EBR	WBL	WBT	WBR	NBL	NBT	NBR	SBL	SBT	SBR
Lane Configurations		↕			↕			↕			↕	
Volume (veh/h)	20	55	5	10	60	15	5	20	5	5	5	20
Sign Control		Free			Free			Stop			Stop	
Grade		0%			0%			0%			0%	
Peak Hour Factor	0.82	0.82	0.82	0.82	0.82	0.82	0.82	0.82	0.82	0.82	0.82	0.82
Hourly flow rate (vph)	24	67	6	12	73	18	6	24	6	6	6	24
Pedestrians												
Lane Width (ft)												
Walking Speed (ft/s)												
Percent Blockage												
Right turn flare (veh)												
Median type		None			None							
Median storage (veh)												
Upstream signal (ft)												
pX, platoon unblocked												
vC, conflicting volume	91			73			253	235	70	244	229	82
vC1, stage 1 conf vol												
vC2, stage 2 conf vol												
vCu, unblocked vol	91			73			253	235	70	244	229	82
tC, single (s)	4.1			4.1			7.1	6.5	6.2	7.1	6.5	6.2
tC, 2 stage (s)												
tF (s)	2.2			2.2			3.5	4.0	3.3	3.5	4.0	3.3
p0 queue free %	98			99			99	96	99	99	99	98
cM capacity (veh/h)	1503			1527			665	650	993	673	655	977

Direction, Lane #	EB 1	WB 1	NB 1	SB 1
Volume Total	98	104	37	37
Volume Left	24	12	6	6
Volume Right	6	18	6	24
cSH	1503	1527	692	844
Volume to Capacity	0.02	0.01	0.05	0.04
Queue Length 95th (ft)	1	1	4	3
Control Delay (s)	2.0	0.9	10.5	9.5
Lane LOS	A	A	B	A
Approach Delay (s)	2.0	0.9	10.5	9.5
Approach LOS			B	A

Intersection Summary			
Average Delay		3.7	
Intersection Capacity Utilization	17.8%		ICU Level of Service
Analysis Period (min)		15	A

# HCM Unsignalized Intersection Capacity Analysis

## 10: SW 5th St & SE Edwards Dr

3/15/2012



Movement	EBL	EBR	NBL	NBT	SBT	SBR
Lane Configurations						
Volume (veh/h)	2	50	35	5	2	5
Sign Control	Stop			Free	Free	
Grade	0%			0%	0%	
Peak Hour Factor	0.86	0.86	0.86	0.86	0.86	0.86
Hourly flow rate (vph)	2	58	41	6	2	6
Pedestrians						
Lane Width (ft)						
Walking Speed (ft/s)						
Percent Blockage						
Right turn flare (veh)						
Median type				None	None	
Median storage (veh)						
Upstream signal (ft)						
pX, platoon unblocked						
vC, conflicting volume	92	5	8			
vC1, stage 1 conf vol						
vC2, stage 2 conf vol						
vCu, unblocked vol	92	5	8			
tC, single (s)	6.4	6.2	4.1			
tC, 2 stage (s)						
tF (s)	3.5	3.3	2.2			
p0 queue free %	100	95	97			
cM capacity (veh/h)	885	1078	1612			
<b>Direction, Lane #</b>	<b>EB 1</b>	<b>NB 1</b>	<b>SB 1</b>			
Volume Total	60	47	8			
Volume Left	2	41	0			
Volume Right	58	0	6			
cSH	1069	1612	1700			
Volume to Capacity	0.06	0.03	0.00			
Queue Length 95th (ft)	4	2	0			
Control Delay (s)	8.6	6.4	0.0			
Lane LOS	A	A				
Approach Delay (s)	8.6	6.4	0.0			
Approach LOS	A					
<b>Intersection Summary</b>						
Average Delay			7.1			
Intersection Capacity Utilization		18.9%		ICU Level of Service		A
Analysis Period (min)			15			



# HCM Unsignalized Intersection Capacity Analysis

## 11: SE Parks Dr & SE Edwards Dr

3/15/2012



Movement	EBL	EBR	NBL	NBT	SBT	SBR
Lane Configurations						
Volume (veh/h)	20	2	0	5	5	10
Sign Control	Stop			Free	Free	
Grade	0%			0%	0%	
Peak Hour Factor	0.73	0.73	0.73	0.73	0.73	0.73
Hourly flow rate (vph)	27	3	0	7	7	14
Pedestrians						
Lane Width (ft)						
Walking Speed (ft/s)						
Percent Blockage						
Right turn flare (veh)						
Median type				None	None	
Median storage (veh)						
Upstream signal (ft)						
pX, platoon unblocked						
vC, conflicting volume	21	14	21			
vC1, stage 1 conf vol						
vC2, stage 2 conf vol						
vCu, unblocked vol	21	14	21			
tC, single (s)	6.4	6.2	4.1			
tC, 2 stage (s)						
tF (s)	3.5	3.3	2.2			
p0 queue free %	97	100	100			
cM capacity (veh/h)	996	1066	1595			
Direction, Lane #	EB 1	NB 1	SB 1			
Volume Total	30	7	21			
Volume Left	27	0	0			
Volume Right	3	0	14			
cSH	1002	1595	1700			
Volume to Capacity	0.03	0.00	0.01			
Queue Length 95th (ft)	2	0	0			
Control Delay (s)	8.7	0.0	0.0			
Lane LOS	A					
Approach Delay (s)	8.7	0.0	0.0			
Approach LOS	A					
Intersection Summary						
Average Delay			4.6			
Intersection Capacity Utilization		13.3%		ICU Level of Service		A
Analysis Period (min)			15			





TABLE 3

Function	Key	Phase Number
Year	0	1 2 3 4 5 6 7 8
Month	1	
Date	2	
Day of Week	3	
Hour	4	
Minute	5	
Second	6	
1/10 Second	7	
Start Yellow	8	
EVA Phases	9	
EVB Phases	A	
EVC Phases	B	
EVD Phases	C	
Handicap Ped	D	
	E	

TABLE 6 (also see sheet 6)

Function	Code	Value	Notes
Floating Ped	2E		0 = Off, 1 = On (Ph. 7 & 8 Not permitted)
ID Number	2F	49	Range 0 to 253 (1)
Coordination	3E	1	0 = Recall, 1 = No. Recall
Ped Recalls	3F		0 = Off, 1 = ON
Rest in WALK	4E		Extend time for green after sign turns on (2) (5)
Advance Warning	4F		Delay time for sign after phase turns yellow (2) (5)
RR Red Clear	5E		Length of all red after RR red flash
RR Clear Color	5F		0 = Green, 1 = Flash Yellow, 2 = Flash Red
NEMA Inputs	66		Non zero value reassigns C1 inputs. (3)
Bus Delay	6D		Delay time before preemption (4)
Bus Timer # 1	6E		Extension of max green for phases 2 & 6 (Free operation)
Bus Timer # 3	6F		Force off time for Ph 4 & 8 (only in Free operation)
JHK Protocol	76		0 = no, 0.1 = yes
JHK Area No. & 1st digit local	7D		Area No. 0 - 7 and Local 001 - 510 (1)
EV minimum timed Start / end of call	7E		0 = at start of call, 1 = at end of call
EV On Indicators	7F		0 = Off, 1 = Flash, 5 = solid indication (5)

Notes

- (1) JHK ID no. is formed by Area no. (0 to 7) and 3 digit Local no. (001-510). Left most digit entered as xx in location 7D and rightmost as xx in location 2F
- (2) See Sheet 6, Location B+0+E
- (3) C1 pins 54, 63, 64, 75, 76, and 77. See sheet 6, Location B+0+D
- (4) Entering 25.5 in this location is the only way of disabling bus preempt.
- (5) Ped yellow outputs, C1-35, 36, 37, and 38 are used by Rt. Turn Overlaps, EV on indicators, TOD/DOW programmable outputs, Fiber Optic sign for RR flash yellow clearance, and Advance Warning sign operation.

Phase Rotation Diagram

T. E. O. S. Dwg. Nos:

NORMAL PHASE ROTATION DIAGRAM

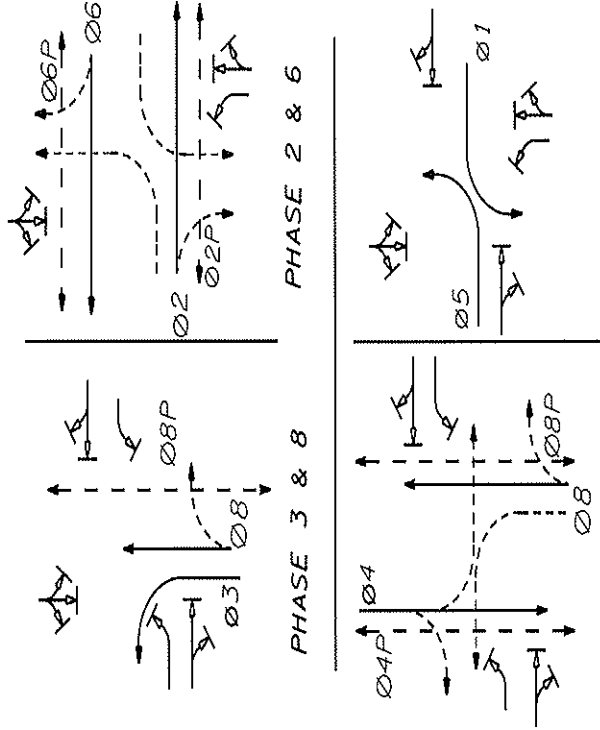

EMERGENCY PRE-EMPTION OPERATION

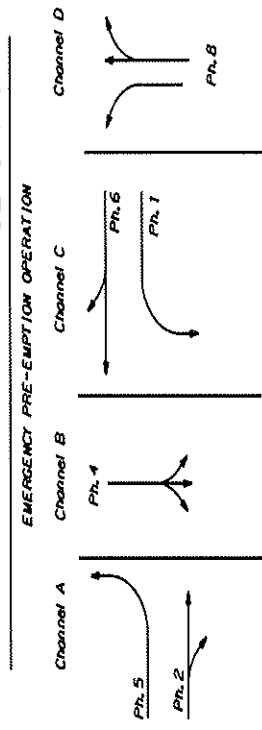

Table Numbers refer to Trafficview & Translink

**TABLE 1 Page 0**

Function	Key	Phase Number *							
		1	2	3	4	5	6	7	8
Veh Recall	0	X							
Ped Recall	1								
Red Lock	2								
Yellow Lock	3								
Permit Phase	4	X	X	X	X	X	X	X	X
Ped Phases	5	X	X	X	X	X	X	X	X
Lead Phases	6	X	X	X	X	X	X	X	X
Double Entry	7								
Sequential	8								
Start Green	9	X	X						
OLA=	A	X	X						
OLB=	B								
OLC=	C								
OLD=	D								
Exclusive	E								
Sim Gap	F								

**TABLE 1 Page 0**

Interval	Key	Phase Number							
		1	2	3	4	5	6	7	8
Max Green	0	20	70	20	20	20	70		20
Max2 / HFDW	1	20	100	20	20	20	100		20
Walk	2		7		7		7		7
Flashing DW	3		25		19		28		20
Max Initial	4	3	15	3	3	3	15		3
Min Green	5	3	10	3	3	3	10		3
TBR	6	5	10	5	5	5	10		5
TTR	7	10	20	10	10	10	20		10
Observe Gap	8								
Passage	9	2.5	5.0	2.5	2.5	2.5	5.0		2.5
Min Gap	A	1.5	4.0	1.5	1.5	1.5	4.0		1.5
Add per Act	B		1.4				1.4		
Yellow	C	4.0	5.0	4.0	3.5	4.0	5.0		3.5
Red Clear	D	0.5	0.5	0.5	1.0	0.5	0.5		1.0
Red Revert	E	5.0	5.0	5.0	5.0	5.0	5.0		5.0
Walk 2	F								

**TABLE 2 Page 0**

Parameter	Key	Value	Notes
Short Pwr Dn	0		Clock Correction Speed up 1 - 9 Slow down 11 - 19
Long Power Dn	1		
Delay Types Preemption	EVA	2	Preemption Delay Types:
	EVB	3	
	EVC	4	Hold 1 Latch 2
	EVD	5	Both 3 Neither 0
	RR	6	
	Ped Inhibit	7	
OLA	Green	8	
	Yellow	9	
	Green	A	Overlap Yellow Time should always be specified
OLB	Yellow	B	
	Green	C	
OLC	Yellow	D	
	Green	E	
OLD	Yellow	F	

Keyboard Entries when not in Free Display  
 A Advance D Column Advance  
 B Back E Enter and Advance  
 C Clear Display F Free Display

Remitilization  
 D + 1 + F + 1 + E  
 (Use only when in flash)

Phase Data Copy  
 C + x + C + y + D  
 x From Phase (x cannot be 3 or 8)  
 y To Phase(s) - up to 3 at a time

Phase Conditions as shown on Free Display

- 00 Initial Entry
- 02 WALK
- 03 Flashing DW
- 05 Min Green
- 08 Rest
- 09 Passage
- 0B Added Initial
- 0C Yellow
- 0D Red Clear
- 0E Red Revert
- 11 Gap Out
- 12 Force Off
- 14 Max Out
- 15 Red Revert Timed out

To observe timing for an individual phase:  
 Enter C + A + F for Ring A (Phase 1-4) or  
 enter C + B + F for Ring B (Phase 5-8)

**TABLE 2 Page 0**

Function	Key	Value	Phase Number							
			1	2	3	4	5	6	7	8
RT OLE	8									
RT OLF	9									
Red Rest	A									
Max Recall	B									
Flash Green	C									
Advance WALK	D									
Restrictive Ph	E									
	F									

\* Shown on Call/Active Display



Date sheet in effect:

Date sheet voided:

Location: 99W @ 5th St.

Dundee

TABLE 1 Page 1

Function	Phase Number *							
	1	2	3	4	5	6	7	8
Veh Recall		X						X
Ped Recall								
Red Lock								
Yellow Lock								
Permit Phase	X	X	X	X	X	X	X	X
Ped Phases	X	X	X	X	X	X	X	X
Lead Phases	X	X	X	X	X	X	X	X
Double Entry								
Sequential								
Start Green		X						X
OLA=		X	X					
OLB=								
OLC=								
OLD=								
Exclusive								
Sim Gap								

TABLE 1 Page 1

Interval	Key	Phase Number							
		1	2	3	4	5	6	7	8
Max Green	0	20	120	20	20	20	120		20
Max2 / HFDW	1	20	120	20	20	20	120		20
Walk	2		7		7		7		7
Flashing DW	3		25		19		28		20
Max Initial	4	3	15	3	3	3	15		3
Min Green	5	3	10	3	3	3	10		3
TBR	6	5	10	5	5	5	10		5
TTR	7	10	20	10	10	10	20		10
Observe Gap	8								
Passage	9	2.5	5.0	2.5	2.5	2.5	5.0		2.5
Min Gap	A	1.5	4.0	1.5	1.5	1.5	4.0		1.5
Add per Act	B		1.4				1.4		
Yellow	C	4.0	5.0	4.0	3.5	4.0	5.0		3.5
Red Clear	D		0.5		1.0		0.5		1.0
Red Revert	E	5.0	5.0	5.0	5.0	5.0	5.0		5.0
Walk 2	F								

To observe timing for an individual phase:  
 Enter C + A + F for Ring A (Phase 1-4) or  
 enter C + B + F for Ring B (Phase 5-8)

Phase Conditions as shown on Free Display

00	Initial Entry	0C	Yellow
02	WALK	0D	Red Clear
03	Flashing DW	0E	Red Revert
05	Min Green	11	Gap Out
08	Rest	12	Force Off
09	Passage	14	Max Out
0B	Added Initial	15	Red Revert Timed out

Page I.D. 1

TABLE 2 Page 1

Miscellaneous (D+C+9+Key)			
Parameter	Key	Value	Notes
Short Pwr Dn	0		Clock Correction Speed up 1 - 9 Slow down 11 - 19
Long Power Dn	EVA	2	Preemption
	EVB	3	Delay Types:
	EVC	4	Hold 1
	EVD	5	Latch 2
	RR	6	Both 3
			Neither 0
Ped Inhibit	7		Usually "0"
	8		
OLA	Green		
	Yellow		
OLB	Green		Overlap
	Yellow		Yellow
OLC	Green		Time
	Yellow		should
OLD	Green		always be
	Yellow		specified

Keyboard Entries when not in Free Display

A	Advance	D	Column Advance
B	Back	E	Enter and Advance
C	Clear Display	F	Free Display

Reinitialization  
 D + 1 + F + 1 + E  
 (Use only when in flash)

Phase Data Copy  
 C + X + C + Y + D  
 x From Phase (x cannot be 3 or 8)  
 y To Phase(s) - up to 3 at a time

TABLE 2 Page 1

Function	Value	Phase Number							
		1	2	3	4	5	6	7	8
Page ID	0								
1									
2									
3									
OLA Red									
OLB Red									
OLC Red									
OLD Red									
RT OLE	8								
RT OLF	9								
Red Rest	A								
Max Recall	B								
Flash Green	C								
Advance WALK	D								
Restrictive Ph	E								
	F								

\* Shown on Call/Active Display

**TABLE 1 Page 2**

Function	Phase Number *							
	1	2	3	4	5	6	7	8
Veh Recall		X						
Ped Recall								
Red Lock								
Yellow Lock								
Permit Phase		X	X	X	X	X	X	X
Ped Phases		X	X	X	X	X	X	X
Lead Phases		X	X	X	X	X	X	X
Double Entry								
Sequential								
Start Green			X					
OLA=		X	X					
OLB=								
OLC=								
OLD=								
Exclusive								
Sim Gap								

**TABLE 1 Page 2**

Interval	Key	Phase Number							
		1	2	3	4	5	6	7	8
Max Green	0	20	50	35	35	20	50		35
Max2 / HFDW	1	20	100	35	35	20	100		35
Walk	2		7		7		7		7
Flashing DW	3		25		19		28		20
Max Initial	4	3	15	3	3	3	15		3
Min Green	5	3	10	3	3	3	10		3
TBR	6	5	10	5	5	5	10		5
TTR	7	10	20	10	10	10	20		10
Observe Gap	8								
Passage	9	2.5	5.0	2.5	2.5	2.5	5.0		2.5
Min Gap	A	1.5	4.0	1.5	1.5	1.5	4.0		1.5
Add per Act	B		1.4				1.4		
Yellow	C	4.0	5.0	4.0	3.5	4.0	5.0		3.5
Red Clear	D		0.5		1.0		0.5		1.0
Red Revert	E	5.0	5.0	5.0	5.0	5.0	5.0		5.0
Walk 2	F								

**TABLE 2 Page 2**

Miscellaneous (D+D+9+Key)			
Parameter	Key	Value	Notes
Short Pwr Dn	0		Clock Correction Speed up 1 - 9 Slow down 11 - 19
Long Power Dn	1		Preemption Delay Types:
Preemption Delay Types	EVA	2	
	EVB	3	
	EVC	4	Hold 1 Latch 2
	EVD	5	Both 3 Neither 0
RR	6		
Ped Inhibit	7		Usually "0"
OLA	Green	8	
	Yellow	9	
OLB	Green	A	Overlap Yellow
	Yellow	B	Time should always be specified
OLC	Green	C	
	Yellow	D	
OLD	Green	E	
	Yellow	F	

Keyboard Entries when not in Free Display  
 A Advance D Column Advance  
 B Back E Enter and Advance  
 C Clear Display F Free Display

Phase Conditions as shown on Free Display

- 00 Initial Entry
- 01 Yellow
- 02 WALK
- 03 Red Clear
- 04 Flashing DW
- 05 Min Green
- 06 Rest
- 07 Passage
- 08 Added Initial
- 09 Red Revert Timed out
- 10 Yellow
- 11 Gap Out
- 12 Force Off
- 13 Max Out
- 14 Red Revert
- 15 Red Revert

To observe timing for an individual phase:  
 Enter C + A + F for Ring A (Phase 1-4) or  
 enter C + B + F for Ring B (Phase 5-8)

**TABLE 2 Page 2**

Function	Value	Phase Number							
		1	2	3	4	5	6	7	8
Page ID	0								
1									
2									
3									
OLA Red									
OLB Red									
OLC Red									
OLD Red									
RT OLE	8								
RT OLF	9								
Red Rest	A								
Max Recall	B								
Flash Green	C								
Advance WALK	D								
Restrictive Ph.	E								
	F								

\* Shown on Call/Active Display

TABLE 6 (Also see sheet 2)

Operation (B + 0 + Key)	Parameter	Value
0	Present Plan	
1	Time of Day Plan	
2	Hardwire Plan	
3	MODEM Plan	
4	Mode (0 - 4 see right)	
5	Master (0 - 4 see right)	
6	Master Cycle Clock	
7	Local Cycle Clock	
8	Local Timer	
9		
A		
B		

	Phase Number							
	1	2	3	4	5	6	7	8
C								
D								
E								
F	X	X	X	X	X	X	X	X

OSM ?  Y  N

OSM Location \_\_\_\_\_

0 = Free  
1 = TBC  
2 = Herowire

3 = Modem  
4 = TM System

0 = Off  
1 = Modem Master  
2 = Herowire Master

3 = 1 + 2  
4 = TM Master

Manual  
(D + 1 + E)

TABLE 13 (Also see Sheet 10)

Miscellaneous (E + F + Key)	Function	Time
	Railroad Max 2	0
	Ped Permissive Plan 1	1
	Ped Permissive Plan 2	2
	Ped Permissive Plan 3	3
	Ped Permissive Plan 4	4
	Ped Permissive Plan 5	5
	Ped Permissive Plan 6	6
	Ped Permissive Plan 7	7
	Ped Permissive Plan 8	8
	Ped Permissive Plan 9	9
	Number of Long Powerouts	A
	Number of Short Powerouts	B
	Failed Detector Number	C
	Max 2 On	D
	No Daylight Savings	E 1
	Revision Level	F

TABLE 10 (Also see Sheet 12)

Function	Time Clock On	Time Clock Off	Manual On	Manual Off
Outputs	71	81		
A	72	82		
B	73	83		
C	74	84		
D	25	24		
TOD Red Rest	27	26		
TOD Max Recall	29	28		
TOD Ped Recall	55	54		
WALK 2	1 - 18	0	1 - 18	0
Plan No.	20		20	
Free	19 or 33	32	19 or 33	0
Flash	129	128	129	0
Max 2	131	130		
Det. Count 15	132	130		
Det. Count 60	133		133	
Clear Det. Cl.	136	135		
Det Diagnostic	137	135		
Det Diag Test	138		138	
Clear Det Diag.	199		199	
Send Real Time	100		100	
Time Transfer	101		101	
Page Copy	102		102	
Burn Memory			93	
Print Out			94	
			96	0

Sample Detectors (0 = off, 1 = on)  
Sampling detectors are assigned using extended input codes on Sheet 11

(A + 3 + 9)

Left Turn Type (0, 1, or 2)

0 = Off  
1 = Left turn places call on cross street  
2 = Left turn is omitted until cross street is serviced

TABLE 10 (Also see Sheet 12)

Page 1 (D+A+3+A)	Page 2 (D+A+A+A)
------------------	------------------

Note: This feature works only with leading left turn phases 1, 3, 5, or 7. It is used to prohibit a green arrow from immediately following a green ball.

Note (1) These C1 pins are used for other functions. See note (5) on Sheet 2.



Date sheet in effect:

Date sheet voided:

Location: **99W @ 5th St.**

**Dundee**

**TABLE 5 (2 of 2)**

Event Number	Time Clock Control (D+8+Code)							Hour	Min.	Func		
	S	M	T	W	T	F	S					
	1	2	3	4	5	6	7					
33								80		81	82	83
34								84		85	86	87
35								88		89	8A	8B
36								8C		8D	8E	8F
37								90		91	92	93
38								94		95	96	97
39								98		99	9A	9B
40								9C		9D	9E	9F
41								A0		A1	A2	A3
42								A4		A5	A6	A7
43								A8		A9	AA	AB
44								AC		AD	AE	AF
45								B0		B1	B2	B3
46								B4		B5	B6	B7
47								B8		B9	BA	BB
48								BC		BD	BE	BF

Event Number	Time Clock Control (A+Code)							Hour	Min.	Func		
	S	M	T	W	T	F	S					
	1	2	3	4	5	6	7					
17								C0		C1	C2	C3
18								C4		C5	C6	C7
19								C8		C9	CA	CB
20								CC		CD	CE	CF
21								D0		D1	D2	D3
22								D4		D5	D6	D7
23								D8		D9	DA	DB
24								DC		DD	DE	DF
25								E0		E1	E2	E3
26								E4		E5	E6	E7
27								E8		E9	EA	EB
28								EC		ED	EE	EF
29								F0		F1	F2	F3
30								F4		F5	F6	F7
31								F8		F9	FA	FB
32								FC		FD	FE	FF

**TABLE 5 (1 of 2)**

Event Number	Time Clock Control (A+Code)							Hour	Min.	Func		
	S	M	T	W	T	F	S					
	1	2	3	4	5	6	7					
1	X	X	X	X	X	X	X	80		81	82	83
2	X	X	X	X	X	X	X	84		85	86	87
3	X	X	X	X	X	X	X	88		89	8A	8B
4	X	X	X	X	X	X	X	8C		8D	8E	8F
5	X	X	X	X	X	X	X	90		91	92	93
6	X	X	X	X	X	X	X	94		95	96	97
7	X	X	X	X	X	X	X	98		99	9A	9B
8	X	X	X	X	X	X	X	9C		9D	9E	9F
9	X	X	X	X	X	X	X	A0		A1	A2	A3
10	X	X	X	X	X	X	X	A4		A5	A6	A7
11	X	X	X	X	X	X	X	A8		A9	AA	AB
12	X	X	X	X	X	X	X	AC		AD	AE	AF
13	X	X	X	X	X	X	X	B0		B1	B2	B3
14	X	X	X	X	X	X	X	B4		B5	B6	B7
15	X	X	X	X	X	X	X	B8		B9	BA	BB
16	X	X	X	X	X	X	X	BC		BD	BE	BF

Event Number	Time Clock Control (D+8+Code)							Hour	Min.	Func		
	S	M	T	W	T	F	S					
	1	2	3	4	5	6	7					
49								C0		C1	C2	C3
50								C4		C5	C6	C7
51								C8		C9	CA	CB
52								CC		CD	CE	CF
53								D0		D1	D2	D3
54								D4		D5	D6	D7
55								D8		D9	DA	DB
56								DC		DD	DE	DF
57								E0		E1	E2	E3
58								E4		E5	E6	E7
59								E8		E9	EA	EB
60								EC		ED	EE	EF
61								F0		F1	F2	F3
62								F4		F5	F6	F7
63								F8		F9	FA	FB
64								FC		FD	FE	FF

Event numbers are for reference only.  
Local TOD "Free" will override any plan received via an interconnect line.

**LOCATION:** OR 99W -- SW Niederberger Rd/SE Parks Dr  
**CITY/STATE:** Dundee, OR

**QC JOB #:** 10617213  
**DATE:** 2/2/2011

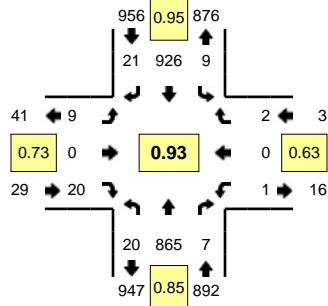

**Peak-Hour: 4:30 PM -- 5:30 PM**  
**Peak 15-Min: 5:15 PM -- 5:30 PM**

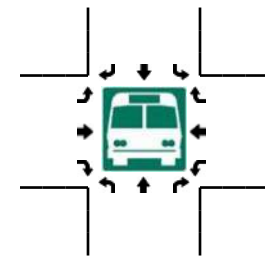
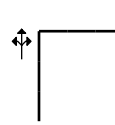
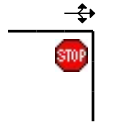
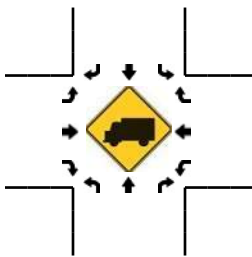
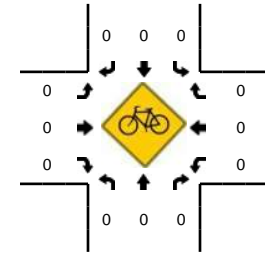
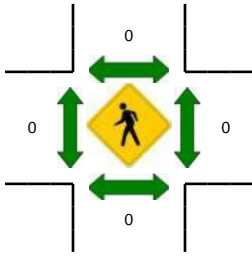
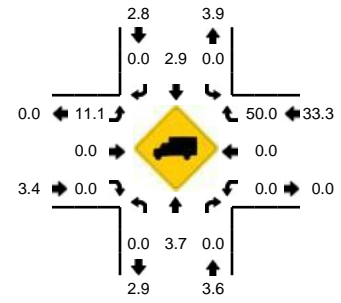

5-Min Count Period Beginning At	OR 99W (Northbound)				OR 99W (Southbound)				SW Niederberger Rd/SE Parks Dr (Eastbound)				SW Niederberger Rd/SE Parks Dr (Westbound)				Total	Hourly Totals
	Left	Thru	Right	U	Left	Thru	Right	U	Left	Thru	Right	U	Left	Thru	Right	U		
4:00 PM	2	59	0	0	0	66	3	0	2	0	3	0	0	0	0	0	135	
4:05 PM	0	66	0	0	0	62	3	0	1	0	2	0	0	0	0	0	134	
4:10 PM	2	73	1	0	0	74	3	0	1	0	2	0	0	0	0	0	156	
4:15 PM	1	82	0	0	0	65	2	0	1	0	0	0	1	1	0	0	153	
4:20 PM	2	80	1	0	0	84	2	0	1	0	1	0	0	0	0	0	171	
4:25 PM	0	80	0	0	2	72	0	0	0	0	4	0	0	0	0	0	158	
4:30 PM	1	65	0	0	1	75	0	0	1	0	2	0	1	0	0	0	146	
4:35 PM	1	64	0	0	0	78	1	0	1	0	2	0	0	0	0	0	147	
4:40 PM	4	64	0	0	1	89	2	0	1	0	1	0	0	0	0	0	162	
4:45 PM	3	89	1	0	1	68	2	0	0	0	1	0	0	0	1	0	166	
4:50 PM	2	63	0	0	4	84	1	0	1	0	0	0	0	0	0	0	155	
4:55 PM	0	61	2	0	0	72	0	0	1	0	3	0	0	0	0	0	139	1822
5:00 PM	0	58	1	0	0	87	2	0	0	0	0	0	0	0	1	0	149	1836
5:05 PM	0	66	0	0	0	78	3	0	0	0	3	0	0	0	0	0	150	1852
5:10 PM	1	84	1	0	0	70	2	0	0	0	2	0	0	0	0	0	160	1856
5:15 PM	1	76	2	0	0	70	3	0	2	0	3	0	0	0	0	0	157	1860
5:20 PM	3	97	0	0	1	78	4	0	1	0	1	0	0	0	0	0	185	1874
5:25 PM	4	78	0	0	1	77	1	0	1	0	2	0	0	0	0	0	164	1880
5:30 PM	1	67	0	0	1	62	2	0	3	0	1	0	0	0	0	0	137	1871
5:35 PM	3	62	2	0	1	82	2	0	0	0	0	0	0	0	1	0	153	1877
5:40 PM	1	71	0	0	1	59	2	0	1	0	0	0	0	0	1	0	136	1851
5:45 PM	0	63	1	0	2	80	2	0	3	0	0	0	0	0	0	0	151	1836
5:50 PM	1	67	0	0	0	75	1	0	3	0	1	0	1	0	0	0	149	1830
5:55 PM	0	56	2	0	0	63	0	0	4	0	1	0	0	0	1	0	127	1818
Peak 15-Min Flowrates	Northbound				Southbound				Eastbound				Westbound				Total	
	Left	Thru	Right	U	Left	Thru	Right	U	Left	Thru	Right	U	Left	Thru	Right	U		
All Vehicles	32	1004	8	0	8	900	32	0	16	0	24	0	0	0	0	0	2024	
Heavy Trucks	0	32	0	0	0	24	0	0	0	0	0	0	0	0	0	0	56	
Pedestrians		0				0					0				0		0	
Bicycles	0	0	0		0	0	0		0	0	0		0	0	0		0	
Railroad																		
Stopped Buses																		

Comments: Video Only

**LOCATION:** OR 99W -- SE 10th St  
**CITY/STATE:** Dundee, OR

**QC JOB #:** 10617212  
**DATE:** 2/2/2011

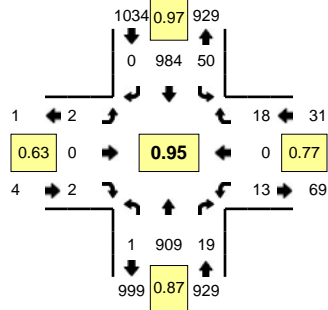

**Peak-Hour: 4:40 PM -- 5:40 PM**  
**Peak 15-Min: 5:15 PM -- 5:30 PM**

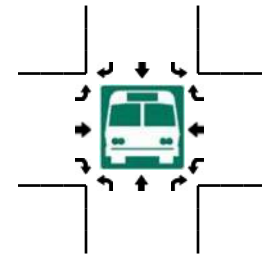
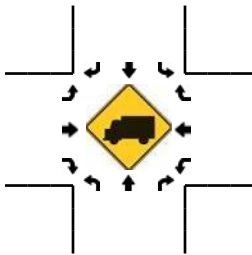
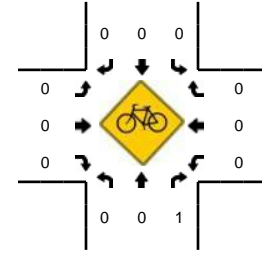
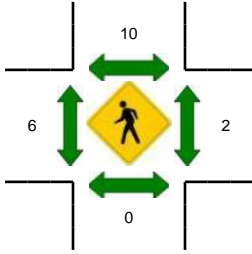
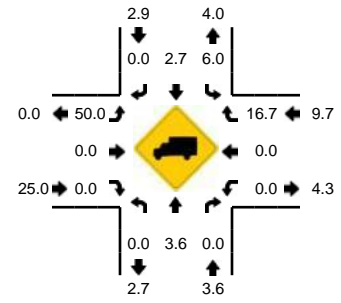

5-Min Count Period Beginning At	OR 99W (Northbound)				OR 99W (Southbound)				SE 10th St (Eastbound)				SE 10th St (Westbound)				Total	Hourly Totals
	Left	Thru	Right	U	Left	Thru	Right	U	Left	Thru	Right	U	Left	Thru	Right	U		
4:00 PM	0	72	0	0	2	69	0	0	0	0	0	0	0	0	0	0	143	
4:05 PM	0	55	1	0	2	72	0	0	1	0	0	0	0	0	3	0	134	
4:10 PM	0	70	1	0	0	89	0	0	0	0	0	0	1	0	3	0	164	
4:15 PM	0	90	1	0	1	68	0	0	0	0	0	0	0	0	0	0	160	
4:20 PM	0	78	1	0	0	94	0	0	1	0	0	0	0	0	2	0	176	
4:25 PM	0	84	1	0	5	70	0	0	0	0	0	0	2	0	0	0	162	
4:30 PM	0	74	0	0	3	81	0	0	0	0	0	0	0	0	1	0	159	
4:35 PM	0	55	1	0	3	94	0	0	0	0	0	0	1	0	4	0	158	
4:40 PM	0	87	1	0	4	86	0	0	0	0	0	0	1	0	3	0	182	
4:45 PM	1	77	2	0	8	77	0	0	0	0	0	0	0	0	2	0	167	
4:50 PM	0	70	1	0	5	89	0	0	1	0	0	0	1	0	2	0	169	
4:55 PM	0	72	0	0	0	85	0	0	1	0	0	0	2	0	1	0	161	1935
5:00 PM	0	53	0	0	7	85	0	0	0	0	0	0	2	0	2	0	149	1941
5:05 PM	0	76	2	0	3	87	0	0	0	0	0	0	1	0	0	0	169	1976
5:10 PM	0	70	3	0	1	77	0	0	0	0	1	0	2	0	1	0	155	1967
5:15 PM	0	82	2	0	9	77	0	0	0	0	0	0	0	0	0	0	170	1977
5:20 PM	0	96	1	0	1	80	0	0	0	0	0	0	0	0	3	0	181	1982
5:25 PM	0	83	3	0	6	80	0	0	0	0	0	0	1	0	2	0	175	1995
5:30 PM	0	77	2	0	2	75	0	0	0	0	1	0	2	0	1	0	160	1996
5:35 PM	0	66	2	0	4	86	0	0	0	0	0	0	1	0	1	0	160	1998
5:40 PM	0	65	0	0	3	69	0	0	0	0	0	0	1	0	2	0	140	1956
5:45 PM	0	68	1	0	3	83	0	0	0	0	1	0	1	0	4	0	161	1950
5:50 PM	0	80	0	0	4	81	0	0	0	0	0	0	1	0	2	0	168	1949
5:55 PM	0	59	0	0	4	69	0	0	0	0	0	0	1	0	2	0	135	1923
Peak 15-Min Flowrates	Northbound				Southbound				Eastbound				Westbound				Total	
	Left	Thru	Right	U	Left	Thru	Right	U	Left	Thru	Right	U	Left	Thru	Right	U		
All Vehicles	0	1044	24	0	64	948	0	0	0	0	0	0	4	0	20	0	2104	
Heavy Trucks	0	28	0	0	4	36	0	0	0	0	0	0	0	0	0	0	68	
Pedestrians		0				16								0			16	
Bicycles	0	0	0		0	0	0		0	0	0		0	0	0		0	
Railroad																		
Stopped Buses																		

Comments: Video Only

**LOCATION:** OR 99W -- SW 1st St  
**CITY/STATE:** Dundee, OR

**QC JOB #:** 10617211  
**DATE:** 2/2/2011

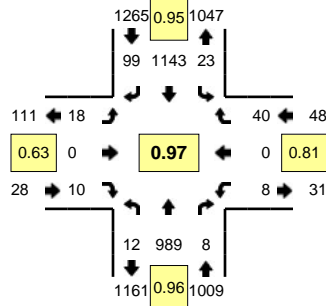

**Peak-Hour: 4:40 PM -- 5:40 PM**  
**Peak 15-Min: 4:40 PM -- 4:55 PM**

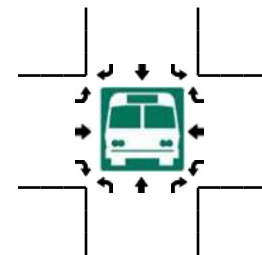
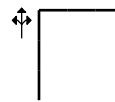
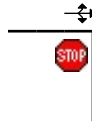
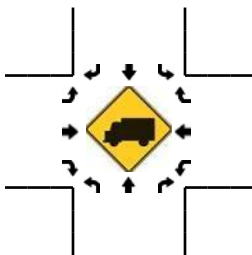
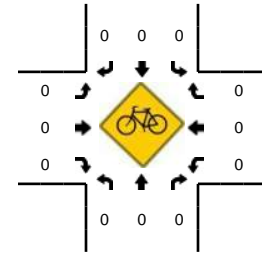
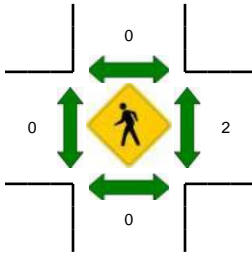
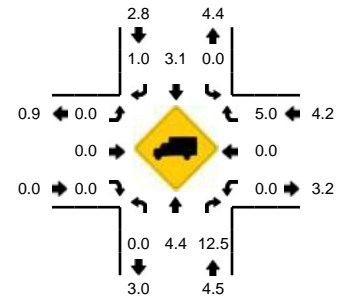

5-Min Count Period Beginning At	OR 99W (Northbound)				OR 99W (Southbound)				SW 1st St (Eastbound)				SW 1st St (Westbound)				Total	Hourly Totals
	Left	Thru	Right	U	Left	Thru	Right	U	Left	Thru	Right	U	Left	Thru	Right	U		
4:00 PM	0	96	3	0	1	71	7	0	2	0	1	0	2	0	5	0	188	
4:05 PM	0	68	2	0	2	79	6	0	1	0	0	0	1	0	3	0	162	
4:10 PM	0	66	2	0	2	97	4	0	3	0	0	0	1	0	2	0	177	
4:15 PM	1	83	0	0	1	87	8	0	1	0	0	0	0	0	2	0	183	
4:20 PM	0	91	0	0	1	92	6	0	1	0	0	0	1	0	6	0	198	
4:25 PM	0	77	1	0	3	88	3	0	1	0	1	0	1	0	4	0	179	
4:30 PM	0	94	3	0	0	91	5	0	1	0	1	0	0	0	1	0	196	
4:35 PM	1	54	3	0	2	96	10	0	1	0	0	0	0	0	7	0	174	
4:40 PM	1	84	0	0	2	105	9	0	0	0	0	0	1	0	2	0	204	
4:45 PM	1	90	2	0	5	97	12	0	0	0	1	0	0	0	2	0	210	
4:50 PM	0	76	0	0	2	96	6	0	1	0	0	0	2	0	7	0	190	
4:55 PM	0	85	0	0	0	96	9	0	2	0	0	0	0	0	2	0	194	2255
5:00 PM	0	71	0	0	2	103	10	0	3	0	0	0	1	0	5	0	195	2262
5:05 PM	2	84	1	0	0	91	7	0	0	0	1	0	1	0	2	0	189	2289
5:10 PM	2	76	1	0	1	81	8	0	2	0	3	0	1	0	4	0	179	2291
5:15 PM	1	90	0	0	1	105	8	0	1	0	1	0	0	0	1	0	208	2316
5:20 PM	1	77	2	0	3	86	7	0	2	0	0	0	0	0	4	0	182	2300
5:25 PM	1	90	1	0	0	83	7	0	0	0	0	0	1	0	5	0	188	2309
5:30 PM	3	83	0	0	6	99	7	0	3	0	3	0	0	0	3	0	207	2320
5:35 PM	0	83	1	0	1	101	9	0	4	0	1	0	1	0	3	0	204	2350
5:40 PM	1	69	3	0	0	93	11	0	1	0	0	0	0	0	4	0	182	2328
5:45 PM	1	80	1	0	3	82	11	0	1	0	0	0	1	0	7	0	187	2305
5:50 PM	1	80	3	0	1	94	5	0	1	0	1	0	0	0	3	0	189	2304
5:55 PM	0	60	3	0	2	85	8	0	2	0	0	0	1	0	5	0	166	2276
Peak 15-Min Flowrates	Northbound				Southbound				Eastbound				Westbound				Total	
	Left	Thru	Right	U	Left	Thru	Right	U	Left	Thru	Right	U	Left	Thru	Right	U		
All Vehicles	8	1000	8	0	36	1192	108	0	4	0	4	0	12	0	44	0	2416	
Heavy Trucks	0	40	0	0	0	40	0	0	0	0	0	0	0	0	0	0	80	
Pedestrians		0				0				0				4			4	
Bicycles	0	0	0	0	0	0	0	0	0	0	0	0	0	0	0	0	0	
Railroad																		
Stopped Buses																		

Comments: Video Only

**LOCATION:** OR 99W -- 5th St  
**CITY/STATE:** Dundee, OR

**QC JOB #:** 10577713  
**DATE:** 2/1/2011

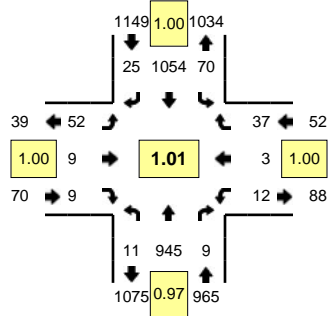

**Peak-Hour: 4:45 PM -- 5:45 PM**  
**Peak 15-Min: 5:15 PM -- 5:30 PM**

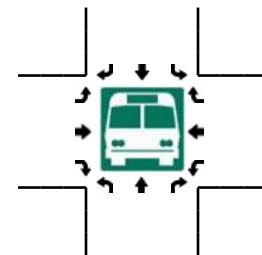
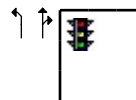
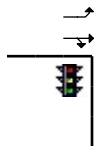
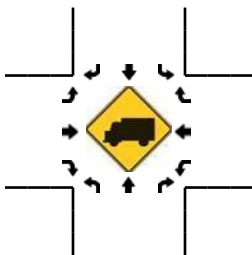
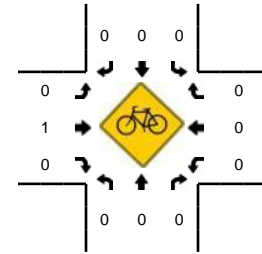
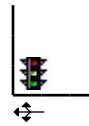
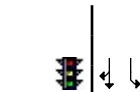
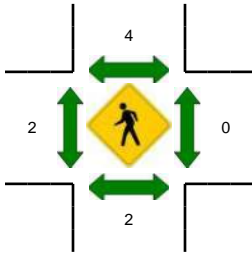
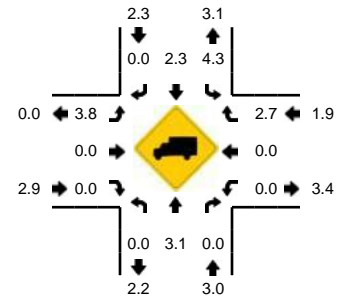

15-Min Count Period Beginning At	OR 99W (Northbound)				OR 99W (Southbound)				5th St (Eastbound)				5th St (Westbound)				Total	Hourly Totals
	Left	Thru	Right	U	Left	Thru	Right	U	Left	Thru	Right	U	Left	Thru	Right	U		
4:00 PM	2	227	2	0	14	246	9	0	18	3	3	0	0	0	6	0	530	
4:15 PM	0	248	1	0	18	247	3	0	7	0	0	0	3	1	11	0	539	
4:30 PM	2	202	4	0	18	269	3	0	10	0	1	0	4	0	18	0	531	
4:45 PM	5	216	3	0	18	273	1	0	13	1	3	0	4	0	15	0	552	2152
5:00 PM	4	237	2	0	14	256	9	0	16	5	2	0	4	0	9	0	558	2180
5:15 PM	0	248	1	0	18	256	8	0	13	1	1	0	1	0	9	0	556	2197
5:30 PM	2	244	3	0	20	269	7	0	10	2	3	0	3	3	4	0	570	2236
5:45 PM	1	206	1	0	10	279	8	0	9	1	3	0	1	0	9	0	528	2212
Peak 15-Min Flowrates	Northbound				Southbound				Eastbound				Westbound				Total	
All Vehicles	0	992	4	0	72	1024	32	0	52	4	4	0	4	0	36	0	2224	
Heavy Trucks	0	24	0	0	0	28	0	0	4	0	0	0	0	0	0	0	56	
Pedestrians	0	0	0	0	0	4	0	0	0	0	0	0	0	0	0	0	4	
Bicycles	0	0	0	0	0	0	0	0	0	0	0	0	0	0	0	0	0	
Railroad	0	0	0	0	0	0	0	0	0	0	0	0	0	0	0	0	0	
Stopped Buses	0	0	0	0	0	0	0	0	0	0	0	0	0	0	0	0	0	

Comments:

**LOCATION:** NE Fox Farm Rd -- OR 99W  
**CITY/STATE:** Dundee, OR

**QC JOB #:** 10577712  
**DATE:** 2/1/2011

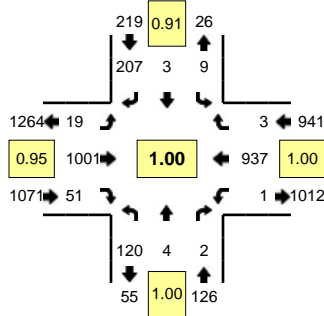

**Peak-Hour: 4:45 PM -- 5:45 PM**  
**Peak 15-Min: 5:15 PM -- 5:30 PM**

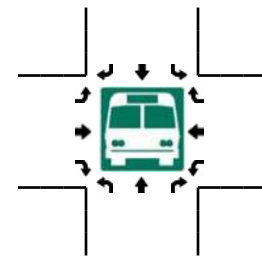
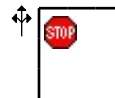
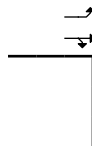
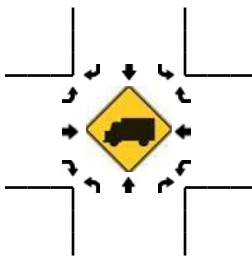
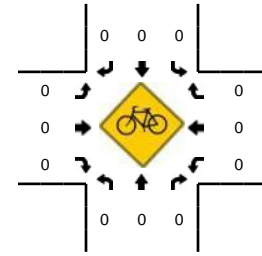
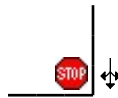
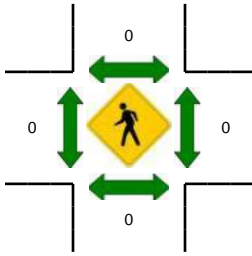
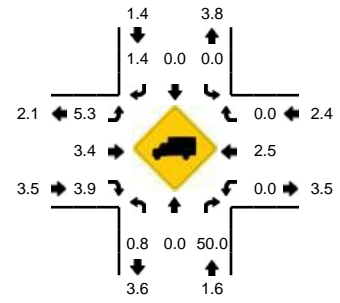

15-Min Count Period Beginning At	NE Fox Farm Rd (Northbound)				NE Fox Farm Rd (Southbound)				OR 99W (Eastbound)				OR 99W (Westbound)				Total	Hourly Totals
	Left	Thru	Right	U	Left	Thru	Right	U	Left	Thru	Right	U	Left	Thru	Right	U		
4:00 PM	25	0	2	0	0	1	20	0	6	249	12	0	0	259	0	0	574	
4:15 PM	24	1	0	0	0	1	39	0	10	245	10	0	0	220	0	0	550	
4:30 PM	34	0	0	0	1	0	55	0	3	214	7	0	0	219	1	0	534	
4:45 PM	25	1	1	0	0	1	57	0	5	242	13	0	1	231	0	0	577	2235
5:00 PM	28	1	0	0	2	0	53	0	4	235	17	0	0	238	0	0	578	2239
5:15 PM	30	1	0	0	3	1	56	0	3	270	8	0	0	214	3	0	589	2278
5:30 PM	37	1	1	0	4	1	41	0	7	254	13	0	0	254	0	0	613	2357
5:45 PM	24	1	1	0	1	0	40	0	7	202	6	0	1	245	2	1	531	2311
Peak 15-Min Flowrates	Northbound				Southbound				Eastbound				Westbound				Total	
All Vehicles	120	4	0	0	12	4	224	0	12	1080	32	0	0	856	12	0	2356	
Heavy Trucks	0	0	0	0	0	0	0	0	0	36	0	0	0	28	0	0	64	
Pedestrians	0	0	0	0	0	0	0	0	0	0	0	0	0	0	0	0	0	
Bicycles	0	0	0	0	0	0	0	0	0	0	0	0	0	0	0	0	0	
Railroad	0	0	0	0	0	0	0	0	0	0	0	0	0	0	0	0	0	
Stopped Buses	0	0	0	0	0	0	0	0	0	0	0	0	0	0	0	0	0	

Comments:



**LOCATION:** SE Edwards Dr -- SE Parks Dr  
**CITY/STATE:** Dundee, OR

**QC JOB #:** 10709006  
**DATE:** Tue, Feb 07 2012

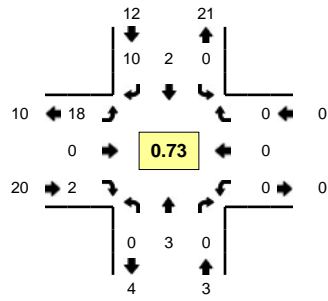

**Peak-Hour: 4:55 PM -- 5:55 PM**  
**Peak 15-Min: 5:40 PM -- 5:55 PM**

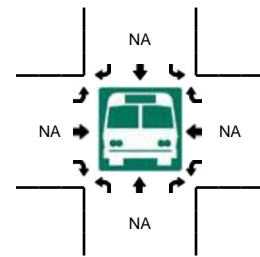
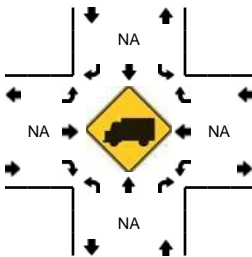
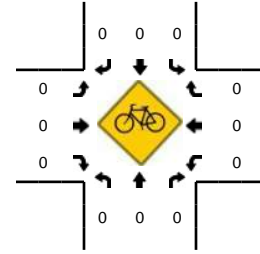
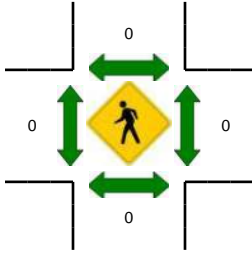
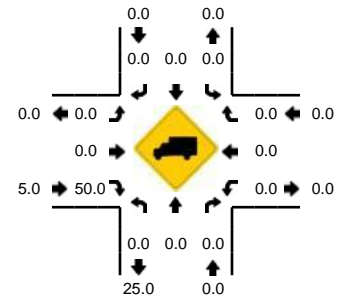

5-Min Count Period Beginning At	SE Edwards Dr (Northbound)				SE Edwards Dr (Southbound)				SE Parks Dr (Eastbound)				SE Parks Dr (Westbound)				Total	Hourly Totals
	Left	Thru	Right	U	Left	Thru	Right	U	Left	Thru	Right	U	Left	Thru	Right	U		
4:00 PM	0	0	0	0	0	0	0	0	0	0	0	0	0	0	0	0	0	23
4:05 PM	0	0	0	0	0	0	1	0	1	0	0	0	0	0	0	0	0	23
4:10 PM	0	1	0	0	0	1	1	0	1	0	0	0	0	0	0	0	0	26
4:15 PM	0	1	0	0	0	0	0	0	0	0	0	0	0	0	0	0	1	27
4:20 PM	0	2	0	0	0	1	1	0	0	0	0	0	0	0	0	0	4	30
4:25 PM	0	2	0	0	0	0	0	0	1	0	1	0	0	0	0	0	4	34
4:30 PM	0	0	0	0	0	0	0	0	0	0	0	0	0	0	0	0	0	34
4:35 PM	0	0	0	0	0	0	2	0	1	0	0	0	0	0	0	0	3	34
4:40 PM	0	1	0	0	0	0	0	0	0	0	0	0	0	0	0	0	1	26
4:45 PM	0	0	0	0	0	0	1	0	1	0	0	0	0	0	0	0	2	27
4:50 PM	0	0	0	0	0	1	1	0	1	0	0	0	0	0	0	0	3	28
4:55 PM	0	0	0	0	0	0	1	0	1	0	1	0	0	0	0	0	3	27
5:00 PM	0	0	0	0	0	0	0	0	1	0	0	0	0	0	0	0	1	28
5:05 PM	0	1	0	0	0	0	1	0	0	0	0	0	0	0	0	0	2	28
5:10 PM	0	0	0	0	0	1	0	0	1	0	0	0	0	0	0	0	2	26
5:15 PM	0	0	0	0	0	0	3	0	1	0	0	0	0	0	0	0	4	29
5:20 PM	0	0	0	0	0	1	0	0	3	0	0	0	0	0	0	0	4	29
5:25 PM	0	1	0	0	0	0	0	0	2	0	0	0	0	0	0	0	3	28
5:30 PM	0	0	0	0	0	0	0	0	3	0	0	0	0	0	0	0	3	31
5:35 PM	0	0	0	0	0	0	0	0	1	0	0	0	0	0	0	0	1	29
5:40 PM	0	1	0	0	0	0	0	0	1	0	0	0	0	0	0	0	2	30
5:45 PM	0	0	0	0	0	0	1	0	2	0	1	0	0	0	0	0	4	32
5:50 PM	0	0	0	0	0	0	4	0	2	0	0	0	0	0	0	0	6	35
5:55 PM	1	0	0	0	0	1	0	0	0	0	0	0	0	0	0	0	2	34
Peak 15-Min Flowrates	Northbound				Southbound				Eastbound				Westbound				Total	
	Left	Thru	Right	U	Left	Thru	Right	U	Left	Thru	Right	U	Left	Thru	Right	U		
All Vehicles	0	4	0	0	0	0	20	0	20	0	4	0	0	0	0	0	48	
Heavy Trucks	0	0	0	0	0	0	0	0	0	0	0	0	0	0	0	0	0	
Pedestrians	0	0	0	0	0	0	0	0	0	0	0	0	0	0	0	0	0	
Bicycles	0	0	0	0	0	0	0	0	0	0	0	0	0	0	0	0	0	
Railroad	0	0	0	0	0	0	0	0	0	0	0	0	0	0	0	0	0	
Stopped Buses	0	0	0	0	0	0	0	0	0	0	0	0	0	0	0	0	0	

Comments:

**LOCATION:** SW Alder St -- SW 9th St  
**CITY/STATE:** Dundee, OR

**QC JOB #:** 10709005  
**DATE:** Tue, Feb 07 2012

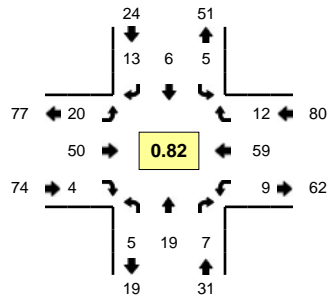

**Peak-Hour: 4:50 PM -- 5:50 PM**  
**Peak 15-Min: 5:05 PM -- 5:20 PM**

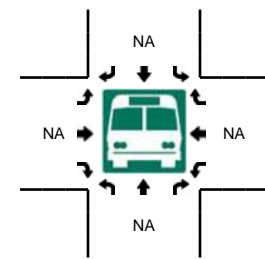
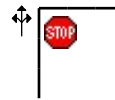
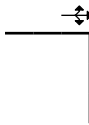
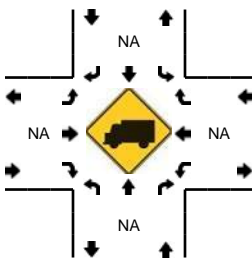
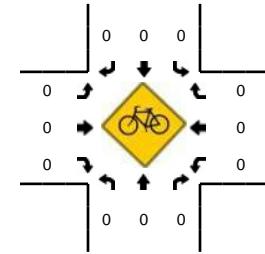
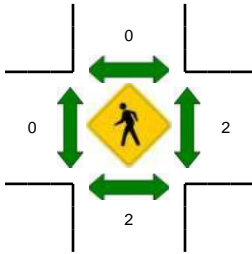
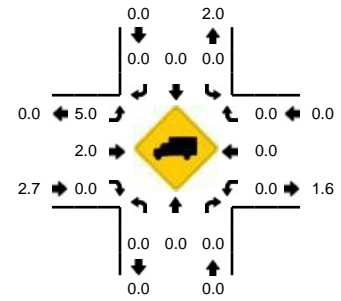

5-Min Count Period Beginning At	SW Alder St (Northbound)				SW Alder St (Southbound)				SW 9th St (Eastbound)				SW 9th St (Westbound)				Total	Hourly Totals
	Left	Thru	Right	U	Left	Thru	Right	U	Left	Thru	Right	U	Left	Thru	Right	U		
4:00 PM	1	2	0	0	0	0	1	0	2	4	0	0	3	4	1	0	18	164
4:05 PM	0	1	2	0	0	0	1	0	4	9	1	0	1	4	0	0	23	173
4:10 PM	0	0	0	0	0	2	1	0	4	8	0	0	1	2	0	0	18	181
4:15 PM	0	1	1	0	1	2	2	0	1	1	1	0	0	2	0	0	12	176
4:20 PM	0	0	0	0	0	1	1	0	5	6	0	0	0	1	1	0	15	175
4:25 PM	0	2	0	0	0	0	0	0	3	5	0	0	1	2	2	0	15	183
4:30 PM	0	0	0	0	0	1	2	0	1	4	0	0	2	5	1	0	16	188
4:35 PM	0	1	0	0	0	0	0	0	1	3	2	0	1	7	1	0	16	186
4:40 PM	0	1	1	0	0	0	2	0	2	4	1	0	0	6	0	0	17	187
4:45 PM	0	0	0	0	1	0	3	0	1	3	0	0	2	2	0	0	12	189
4:50 PM	0	1	0	0	0	0	2	0	3	2	0	0	1	3	1	0	13	188
4:55 PM	1	2	2	0	0	0	0	0	2	0	0	0	0	5	2	0	14	189
5:00 PM	0	1	1	0	0	2	0	0	1	3	0	0	1	9	0	0	18	189
5:05 PM	1	4	1	0	0	1	2	0	3	7	1	0	2	4	0	0	26	192
5:10 PM	0	1	0	0	1	0	1	0	3	2	0	0	1	5	1	0	15	189
5:15 PM	1	3	0	0	2	0	0	0	2	6	2	0	1	5	1	0	23	200
5:20 PM	0	2	0	0	0	1	4	0	0	5	0	0	2	6	0	0	20	205
5:25 PM	1	1	0	0	1	0	1	0	1	2	0	0	0	5	3	0	15	205
5:30 PM	0	2	0	0	0	1	0	0	2	5	0	0	0	4	3	0	17	206
5:35 PM	0	2	1	0	0	1	2	0	1	6	0	0	0	4	0	0	17	207
5:40 PM	1	0	1	0	0	0	1	0	1	8	0	0	0	4	1	0	17	207
5:45 PM	0	0	1	0	1	0	0	0	1	4	1	0	1	5	0	0	14	209
5:50 PM	0	1	1	0	0	0	1	0	1	2	0	0	0	5	1	0	12	208
5:55 PM	0	1	1	0	0	0	0	0	0	2	0	0	3	4	0	0	11	205
Peak 15-Min Flowrates	Northbound				Southbound				Eastbound				Westbound				Total	
	Left	Thru	Right	U	Left	Thru	Right	U	Left	Thru	Right	U	Left	Thru	Right	U		
All Vehicles	8	32	4	0	12	4	12	0	32	60	12	0	16	56	8	0	256	
Heavy Trucks	0	0	0	0	0	0	0	0	0	4	0	0	0	0	0	0	4	
Pedestrians		8				0				0				0			8	
Bicycles	0	0	0	0	0	0	0	0	0	0	0	0	0	0	0	0	0	
Railroad																		
Stopped Buses																		

Comments:

**LOCATION:** SW Alder St -- SW Upland Dr  
**CITY/STATE:** Dundee, OR

**QC JOB #:** 10709004  
**DATE:** Tue, Feb 07 2012

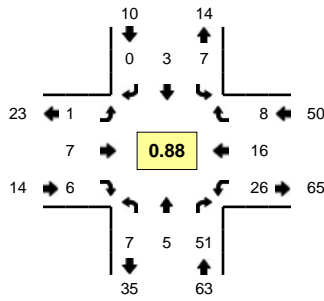

**Peak-Hour: 4:45 PM -- 5:45 PM**  
**Peak 15-Min: 4:55 PM -- 5:10 PM**

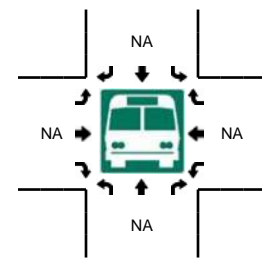
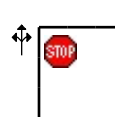
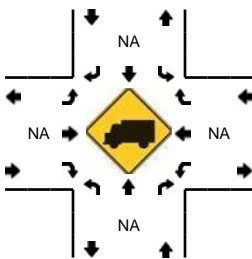
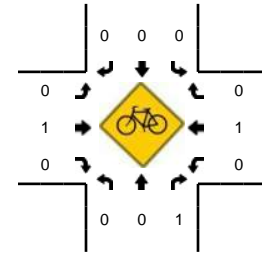
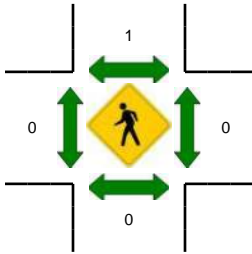
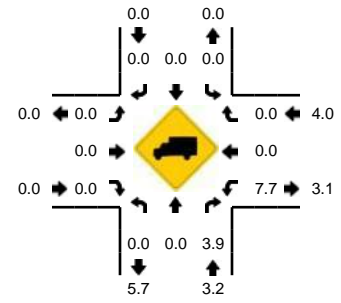

5-Min Count Period Beginning At	SW Alder St (Northbound)				SW Alder St (Southbound)				SW Upland Dr (Eastbound)				SW Upland Dr (Westbound)				Total	Hourly Totals
	Left	Thru	Right	U	Left	Thru	Right	U	Left	Thru	Right	U	Left	Thru	Right	U		
4:00 PM	0	0	3	0	0	0	0	0	0	2	0	0	0	2	0	0	7	118
4:05 PM	0	0	8	0	1	0	0	0	0	1	0	0	0	1	1	0	12	118
4:10 PM	0	0	3	0	0	0	0	0	0	0	0	0	0	2	0	0	5	114
4:15 PM	0	1	4	0	2	1	0	0	0	1	1	0	0	4	3	1	18	113
4:20 PM	0	1	3	0	1	1	0	0	0	0	0	0	0	1	0	0	7	103
4:25 PM	2	0	7	0	0	0	0	0	0	2	1	0	0	1	1	0	14	110
4:30 PM	0	0	3	0	0	0	0	0	0	0	0	0	0	2	0	0	5	108
4:35 PM	0	1	2	0	1	0	0	0	0	1	0	0	0	0	0	0	5	100
4:40 PM	0	0	2	0	1	0	0	0	0	0	0	0	0	2	0	1	6	100
4:45 PM	0	1	0	0	0	1	0	0	0	0	0	0	0	5	0	1	8	101
4:50 PM	1	0	5	0	2	0	0	0	0	1	1	0	0	3	0	1	14	110
4:55 PM	2	1	6	0	0	0	0	0	0	0	1	0	0	1	1	0	12	113
5:00 PM	1	0	3	0	1	0	0	0	0	1	1	0	0	2	2	0	11	117
5:05 PM	0	0	7	0	1	1	0	0	0	0	1	0	0	3	3	0	16	121
5:10 PM	0	1	5	0	0	0	0	0	0	1	1	0	0	1	2	0	11	127
5:15 PM	1	0	6	0	0	0	0	0	0	0	1	0	0	0	3	0	11	120
5:20 PM	0	0	4	0	1	0	0	0	0	1	0	0	0	4	0	1	11	124
5:25 PM	1	0	5	0	0	1	0	0	0	1	1	0	0	1	2	1	13	123
5:30 PM	1	1	7	0	0	0	0	0	0	0	0	0	0	2	1	3	15	133
5:35 PM	0	0	1	0	1	0	0	0	0	2	0	0	0	2	1	0	7	135
5:40 PM	0	1	2	0	1	0	0	0	0	0	0	0	0	2	1	1	8	137
5:45 PM	1	0	1	0	1	0	0	0	0	1	1	0	0	0	1	0	6	135
5:50 PM	1	2	1	0	0	0	0	0	0	0	0	0	0	1	2	0	7	128
5:55 PM	0	0	1	0	1	0	0	0	0	0	2	0	0	0	2	2	6	122
Peak 15-Min Flowrates	Northbound				Southbound				Eastbound				Westbound				Total	
	Left	Thru	Right	U	Left	Thru	Right	U	Left	Thru	Right	U	Left	Thru	Right	U		
All Vehicles	12	4	64	0	8	4	0	0	4	4	8	0	24	24	0	0	156	
Heavy Trucks	0	0	4	0	0	0	0	0	0	0	0	0	0	0	0	0	4	
Pedestrians	0	0	0	0	0	4	0	0	0	0	0	0	0	0	0	0	4	
Bicycles	0	0	0	0	0	0	0	0	0	1	0	0	0	0	0	0	1	
Railroad	0	0	0	0	0	0	0	0	0	0	0	0	0	0	0	0	0	
Stopped Buses	0	0	0	0	0	0	0	0	0	0	0	0	0	0	0	0	0	

Comments:

**LOCATION:** SE Edwards Dr -- SE 5th St  
**CITY/STATE:** Dundee, OR

**QC JOB #:** 10709003  
**DATE:** Tue, Feb 07 2012

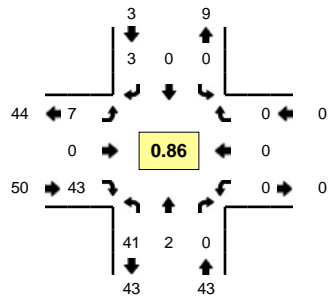

**Peak-Hour: 3:30 PM -- 4:30 PM**  
**Peak 15-Min: 3:45 PM -- 4:00 PM**

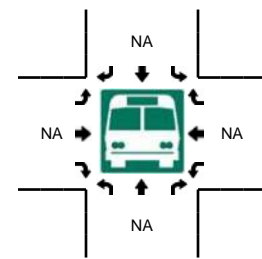
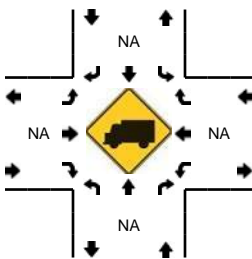
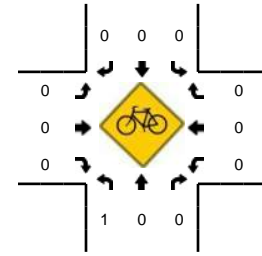
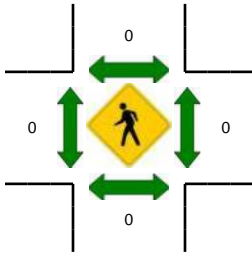
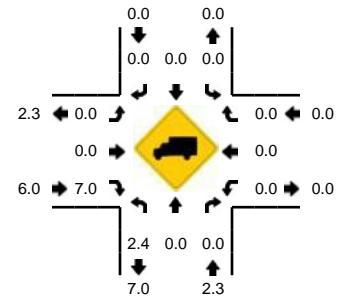

5-Min Count Period Beginning At	SE Edwards Dr (Northbound)				SE Edwards Dr (Southbound)				SE 5th St (Eastbound)				SE 5th St (Westbound)				Total	Hourly Totals
	Left	Thru	Right	U	Left	Thru	Right	U	Left	Thru	Right	U	Left	Thru	Right	U		
3:00 PM	2	0	0	0	0	0	0	0	1	0	0	0	0	0	0	0	3	
3:05 PM	0	0	0	0	0	0	2	0	0	0	0	0	0	0	0	0	2	
3:10 PM	1	0	0	0	0	0	0	0	0	0	3	0	0	0	0	0	4	
3:15 PM	0	0	0	0	0	0	2	0	1	0	3	0	0	0	0	0	6	
3:20 PM	2	0	0	0	0	0	0	0	0	0	2	0	0	0	0	0	4	
3:25 PM	0	0	0	0	0	0	1	0	0	0	2	0	0	0	0	0	3	
3:30 PM	3	0	0	0	0	0	1	0	1	0	4	0	0	0	0	0	9	
3:35 PM	5	0	0	0	0	0	0	0	0	0	4	0	0	0	0	0	9	
3:40 PM	5	0	0	0	0	0	0	0	0	0	4	0	0	0	0	0	9	
3:45 PM	3	0	0	0	0	0	0	0	1	0	5	0	0	0	0	0	9	
3:50 PM	2	0	0	0	0	0	0	0	0	0	5	0	0	0	0	0	7	
3:55 PM	4	1	0	0	0	0	1	0	0	0	6	0	0	0	0	0	12	77
4:00 PM	2	0	0	0	0	0	0	0	3	0	2	0	0	0	0	0	7	81
4:05 PM	3	0	0	0	0	0	0	0	0	0	3	0	0	0	0	0	6	85
4:10 PM	3	0	0	0	0	0	0	0	0	0	3	0	0	0	0	0	6	87
4:15 PM	2	1	0	0	0	0	0	0	1	0	3	0	0	0	0	0	7	88
4:20 PM	4	0	0	0	0	0	1	0	0	0	0	0	0	0	0	0	5	89
4:25 PM	5	0	0	0	0	0	0	0	1	0	4	0	0	0	0	0	10	96
4:30 PM	0	0	0	0	0	0	0	0	0	0	2	0	0	0	0	0	2	89
4:35 PM	1	0	0	0	0	0	5	0	1	0	9	0	0	0	0	0	16	96
4:40 PM	3	1	0	0	0	0	1	0	0	0	4	0	0	0	0	0	9	96
4:45 PM	1	1	0	0	0	0	0	0	0	0	5	0	0	0	0	0	7	94
4:50 PM	4	0	0	0	0	1	1	0	0	0	3	0	0	0	0	0	9	96
4:55 PM	0	0	0	0	0	0	0	0	1	0	5	0	0	0	0	0	6	90
Peak 15-Min Flowrates	Northbound				Southbound				Eastbound				Westbound				Total	
All Vehicles	36	4	0	0	0	0	4	0	4	0	64	0	0	0	0	0	112	
Heavy Trucks	0	0	0	0	0	0	0	0	0	0	0	0	0	0	0	0	0	
Pedestrians	0	0	0	0	0	0	0	0	0	0	0	0	0	0	0	0	0	
Bicycles	0	0	0	0	0	0	0	0	0	0	0	0	0	0	0	0	0	
Railroad																		
Stopped Buses																		

Comments:

**LOCATION:** 99W -- 9th St  
**CITY/STATE:** Dundee, OR

**QC JOB #:** 10709002  
**DATE:** Tue, Feb 07 2012

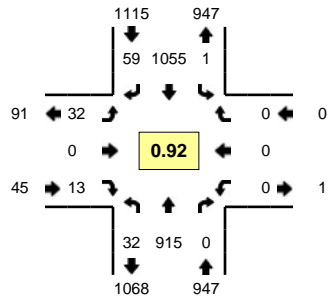

**Peak-Hour: 4:35 PM -- 5:35 PM**  
**Peak 15-Min: 5:15 PM -- 5:30 PM**

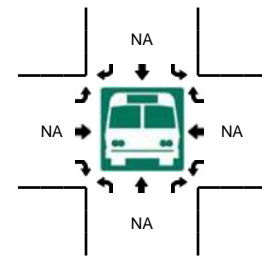
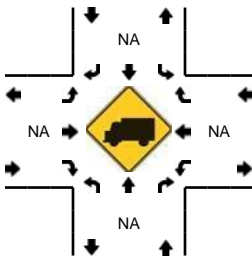
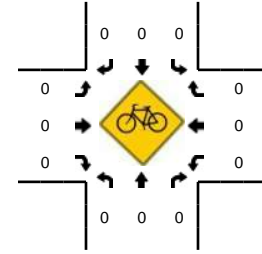
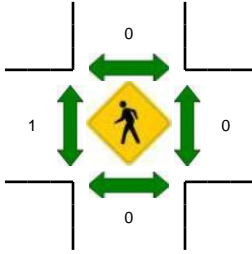
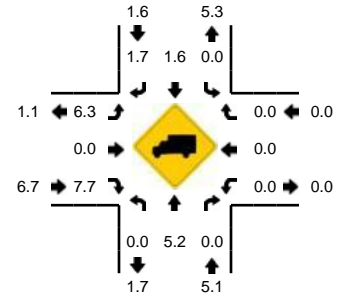

5-Min Count Period Beginning At	99W (Northbound)				99W (Southbound)				9th St (Eastbound)				9th St (Westbound)				Total	Hourly Totals
	Left	Thru	Right	U	Left	Thru	Right	U	Left	Thru	Right	U	Left	Thru	Right	U		
4:00 PM	3	77	0	0	0	70	3	0	1	0	2	0	0	0	0	0	156	1782
4:05 PM	0	72	0	0	0	73	5	0	5	0	4	0	0	0	0	0	159	1816
4:10 PM	0	71	0	0	0	94	5	0	5	0	3	0	0	0	0	0	178	1870
4:15 PM	0	82	0	0	0	94	1	0	2	0	1	0	0	0	0	0	180	1910
4:20 PM	0	71	0	0	0	72	4	0	2	0	0	0	0	0	0	0	149	1919
4:25 PM	2	76	0	0	0	76	5	0	3	0	1	0	0	0	0	0	163	1951
4:30 PM	1	81	0	0	0	79	6	0	3	0	2	0	0	0	0	0	172	1976
4:35 PM	0	64	0	0	0	88	9	0	2	0	2	0	0	0	0	0	165	1991
4:40 PM	3	62	0	0	0	88	5	0	5	0	1	0	0	0	0	0	164	1978
4:45 PM	1	70	0	0	0	89	3	0	1	0	0	0	0	0	0	0	164	1968
4:50 PM	2	86	0	0	0	74	4	0	0	0	4	0	0	0	0	0	170	1986
4:55 PM	3	76	0	0	0	88	5	0	0	0	0	0	0	0	0	0	172	1992
5:00 PM	2	65	0	0	0	89	6	0	3	0	1	0	0	0	0	0	166	2002
5:05 PM	1	65	0	0	0	88	8	0	7	0	0	0	0	0	0	0	169	2012
5:10 PM	7	76	0	0	0	92	1	0	0	0	0	0	0	0	0	0	176	2010
5:15 PM	3	89	0	0	0	99	7	0	4	0	0	0	0	0	0	0	202	2032
5:20 PM	6	91	0	0	0	84	5	0	4	0	2	0	0	0	0	0	192	2075
5:25 PM	3	85	0	0	0	85	1	0	4	0	1	0	0	0	0	0	179	2091
5:30 PM	1	86	0	0	1	91	5	0	2	0	2	0	0	0	0	0	188	2107
5:35 PM	0	77	0	0	0	78	4	0	0	0	6	0	0	0	0	0	165	2107
5:40 PM	1	58	0	0	0	72	4	0	3	0	3	0	0	0	0	0	141	2084
5:45 PM	2	70	0	0	0	79	6	0	7	0	1	0	0	0	0	0	165	2085
5:50 PM	3	72	0	0	0	93	2	0	1	0	3	0	0	0	0	0	174	2089
5:55 PM	2	63	0	0	0	89	3	0	0	0	1	0	0	0	0	0	158	2075
Peak 15-Min Flowrates	Northbound				Southbound				Eastbound				Westbound				Total	
All Vehicles	48	1060	0	0	0	1072	52	0	48	0	12	0	0	0	0	0	2292	
Heavy Trucks	0	48	0	0	0	28	0	0	0	0	0	0	0	0	0	0	76	
Pedestrians		0				0				4			0	0	0	0	4	
Bicycles	0	0	0		0	0	0		0	0	0		0	0	0	0	0	
Railroad																		
Stopped Buses																		

Comments:

**LOCATION:** 99W -- SW 7th St  
**CITY/STATE:** Dundee, OR

**QC JOB #:** 10709001  
**DATE:** Tue, Feb 07 2012

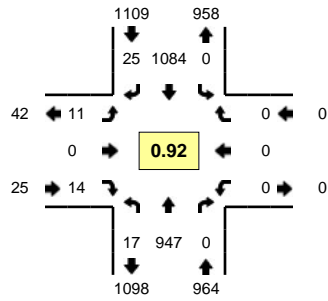

**Peak-Hour: 4:40 PM -- 5:40 PM**  
**Peak 15-Min: 5:15 PM -- 5:30 PM**

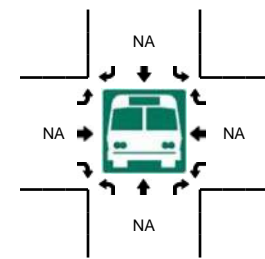
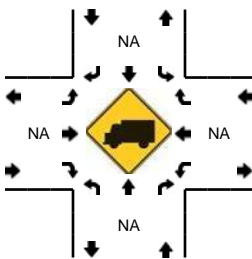
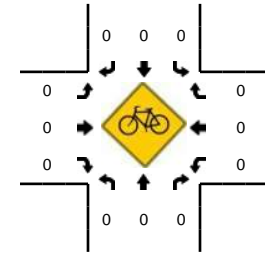
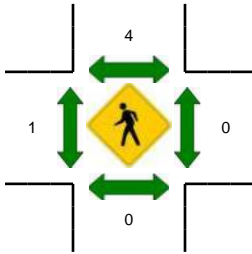
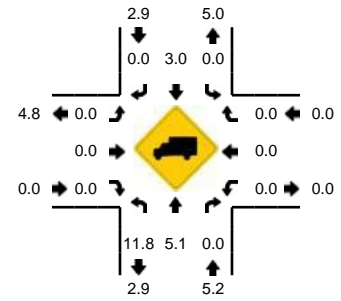

5-Min Count Period Beginning At	99W (Northbound)				99W (Southbound)				SW 7th St (Eastbound)				SW 7th St (Westbound)				Total	Hourly Totals
	Left	Thru	Right	U	Left	Thru	Right	U	Left	Thru	Right	U	Left	Thru	Right	U		
4:00 PM	0	81	0	0	0	68	2	0	2	0	1	0	0	0	0	0	154	1777
4:05 PM	2	67	0	0	0	86	0	0	1	0	0	0	0	0	0	0	156	1813
4:10 PM	1	80	0	0	0	99	2	0	2	0	0	0	0	0	0	0	184	1868
4:15 PM	0	93	0	0	0	95	1	0	2	0	0	0	0	0	0	0	191	1913
4:20 PM	0	76	0	0	0	72	3	0	5	0	0	0	0	0	0	0	156	1928
4:25 PM	1	71	0	0	0	80	2	0	0	0	0	0	0	0	0	0	154	1952
4:30 PM	1	84	0	0	0	84	4	0	0	0	2	0	0	0	0	0	175	1976
4:35 PM	0	69	0	0	0	95	2	0	0	0	1	0	0	0	0	0	167	1991
4:40 PM	0	72	0	0	0	90	3	0	0	0	1	0	0	0	0	0	166	1987
4:45 PM	0	58	0	0	0	89	1	0	1	0	0	0	0	0	0	0	149	1955
4:50 PM	3	88	0	0	0	76	2	0	2	0	1	0	0	0	0	0	172	1979
4:55 PM	0	85	0	0	0	99	2	0	0	0	1	0	0	0	0	0	187	2011
5:00 PM	1	61	0	0	0	99	0	0	1	0	2	0	0	0	0	0	164	2021
5:05 PM	2	67	0	0	0	88	0	0	3	0	3	0	0	0	0	0	163	2028
5:10 PM	1	75	0	0	0	87	2	0	0	0	3	0	0	0	0	0	168	2012
5:15 PM	3	93	0	0	0	104	3	0	0	0	0	0	0	0	0	0	203	2024
5:20 PM	1	92	0	0	0	90	4	0	2	0	1	0	0	0	0	0	190	2058
5:25 PM	2	87	0	0	0	85	2	0	0	0	0	0	0	0	0	0	176	2080
5:30 PM	3	84	0	0	0	95	4	0	1	0	1	0	0	0	0	0	188	2093
5:35 PM	1	85	0	0	0	82	2	0	1	0	1	0	0	0	0	0	172	2098
5:40 PM	0	61	0	0	0	77	1	0	1	0	1	0	0	0	0	0	141	2073
5:45 PM	1	75	0	0	0	89	0	0	1	0	0	0	0	0	0	0	166	2090
5:50 PM	3	69	0	0	0	90	4	0	1	0	3	0	0	0	0	0	170	2088
5:55 PM	3	61	0	0	0	90	2	0	1	0	1	0	0	0	0	0	158	2059
Peak 15-Min Flowrates	Northbound				Southbound				Eastbound				Westbound				Total	
	Left	Thru	Right	U	Left	Thru	Right	U	Left	Thru	Right	U	Left	Thru	Right	U		
All Vehicles	24	1088	0	0	0	1116	36	0	8	0	4	0	0	0	0	0	2276	
Heavy Trucks	8	40	0	0	0	52	0	0	0	0	0	0	0	0	0	0	100	
Pedestrians		0				0				4			0	0	0	0	4	
Bicycles	0	0	0		0	0	0		0	0	0		0	0	0		0	
Railroad																		
Stopped Buses																		

Comments:



# MEMORANDUM #5

**DATE:** August 20, 2013

**TO:** Dundee TSP Update Project Management Team

**FROM:** Carl Springer, P.E., DKS Associates  
Ray Delahanty, AICP, DKS Associates

**SUBJECT: Dundee Transportation System Plan Update  
Future Forecasting**

P11086-003-004

---

The purpose of this memorandum is to present traffic forecasts for Year 2035 for the Dundee Transportation System Plan (TSP) Update and summarize the forecasting methodology. The forecasts are key to identifying future roadway deficiencies and for evaluating potential circulation improvements. The following elements of the forecasting process are discussed:

- **Newberg-Dundee Travel Demand Model**, which estimates average weekday vehicular traffic based on future growth and changing development patterns within Newberg and Dundee, as well as future growth in traffic passing through the region.
- **Projected Land Use Changes** in the areas covered by the model.
- **Trip Generation** based on the projected land use.
- **Trip Distribution**, which estimates the origins and destinations of all the trips generated in the model.
- **Traffic Assignment**, which estimates how trips will be routed on the transportation network.
- **Model Application** to the forecasting process, which uses existing traffic volumes and patterns as a basis.

Traffic volumes were forecast for both the 30<sup>th</sup> highest hour of 2035 (generally representative of a p.m. peak hour from the peak travel month of the year), and for an average weekday p.m. peak hour. These forecast volumes are shown in Figure 1 and Figure 2.



NO SCALE

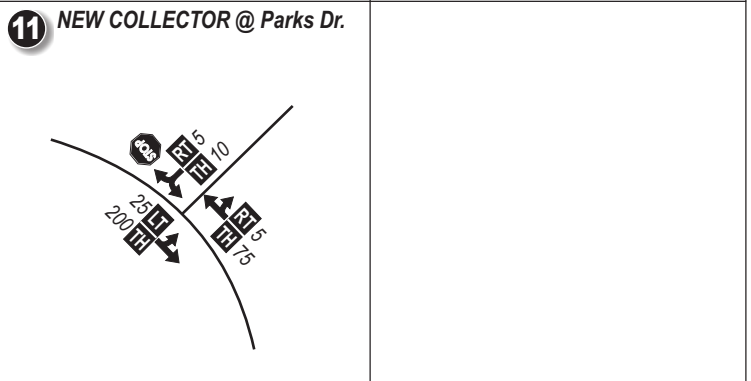
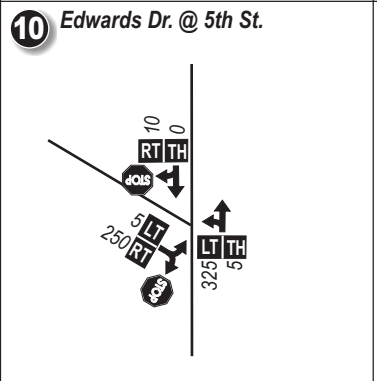
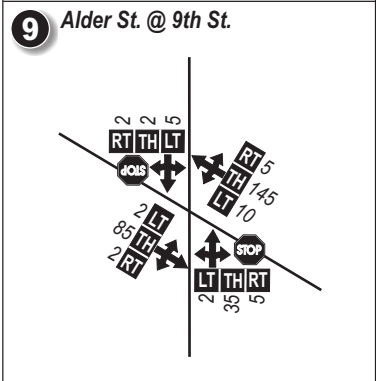
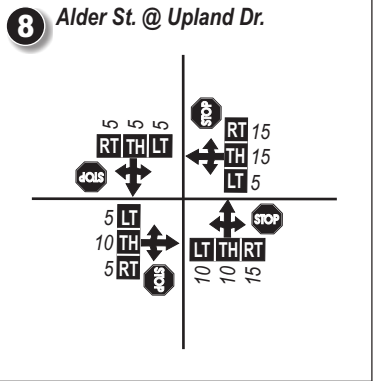
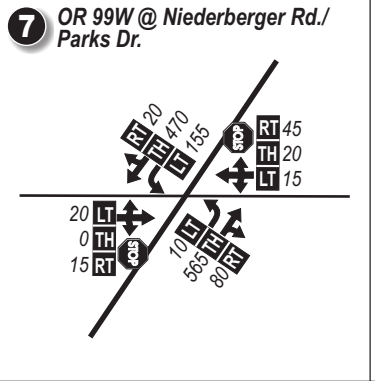
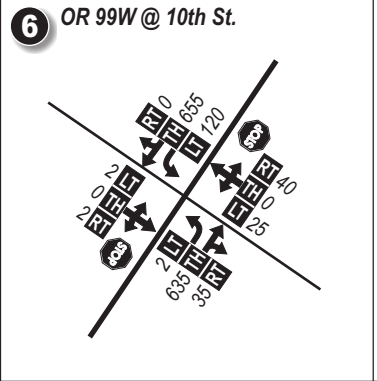
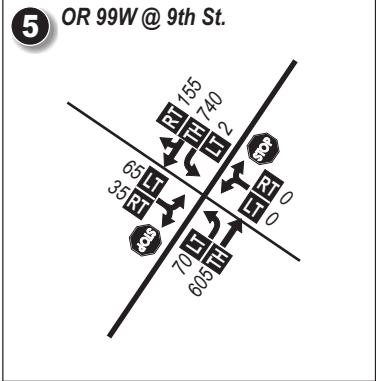
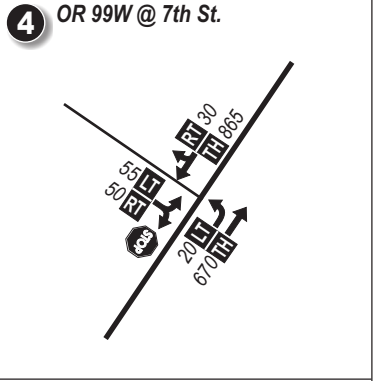
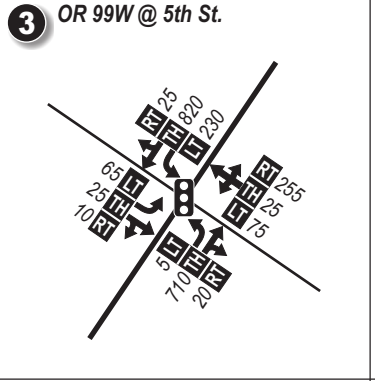
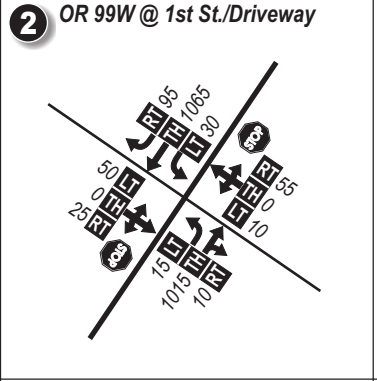
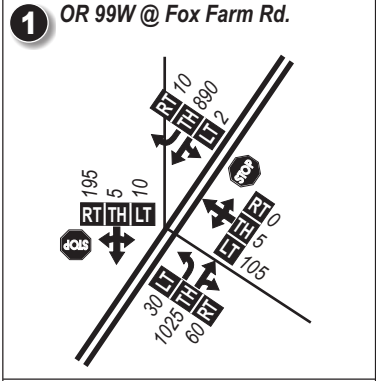
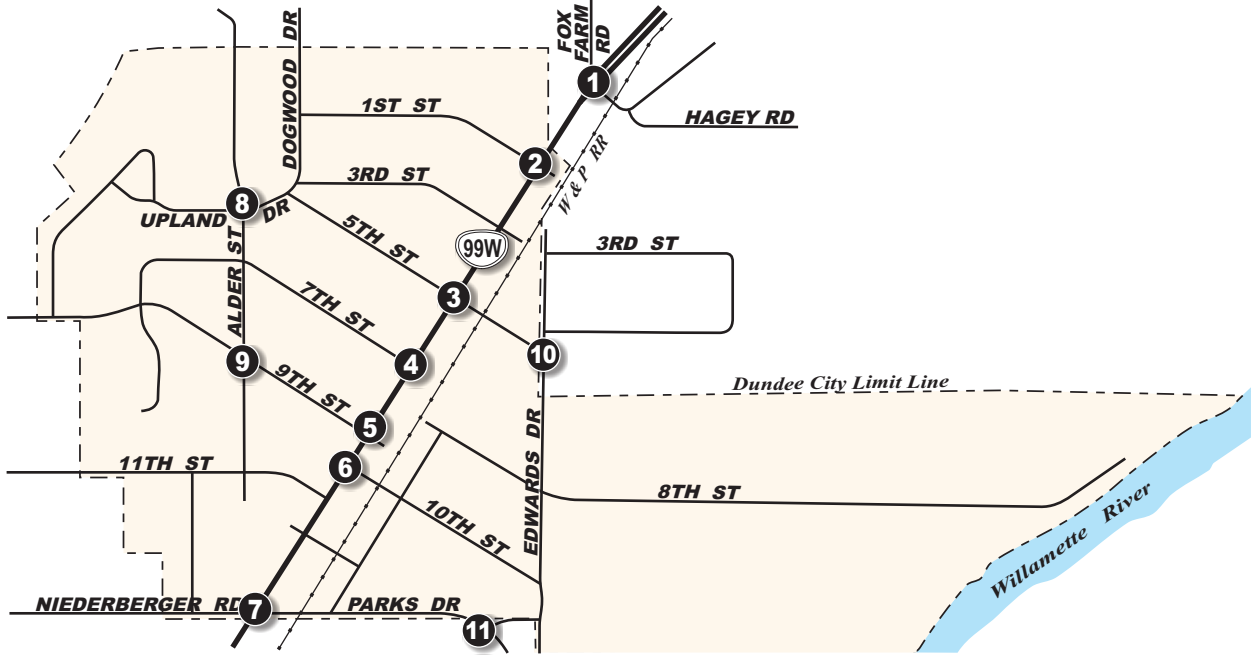

**LEGEND**

- 1** - Study Intersection
- Stop Sign
- Traffic Signal
- Lane Configuration
- 000 - PM Peak Hour Traffic Volumes
- LT TH RT** - Volume Turn Movement  
Left • Thru • Right

**DKS**

**Figure 1**

**YEAR 2035 30HV**  
**PM PEAK HOUR TRAFFIC VOLUMES**



NO SCALE

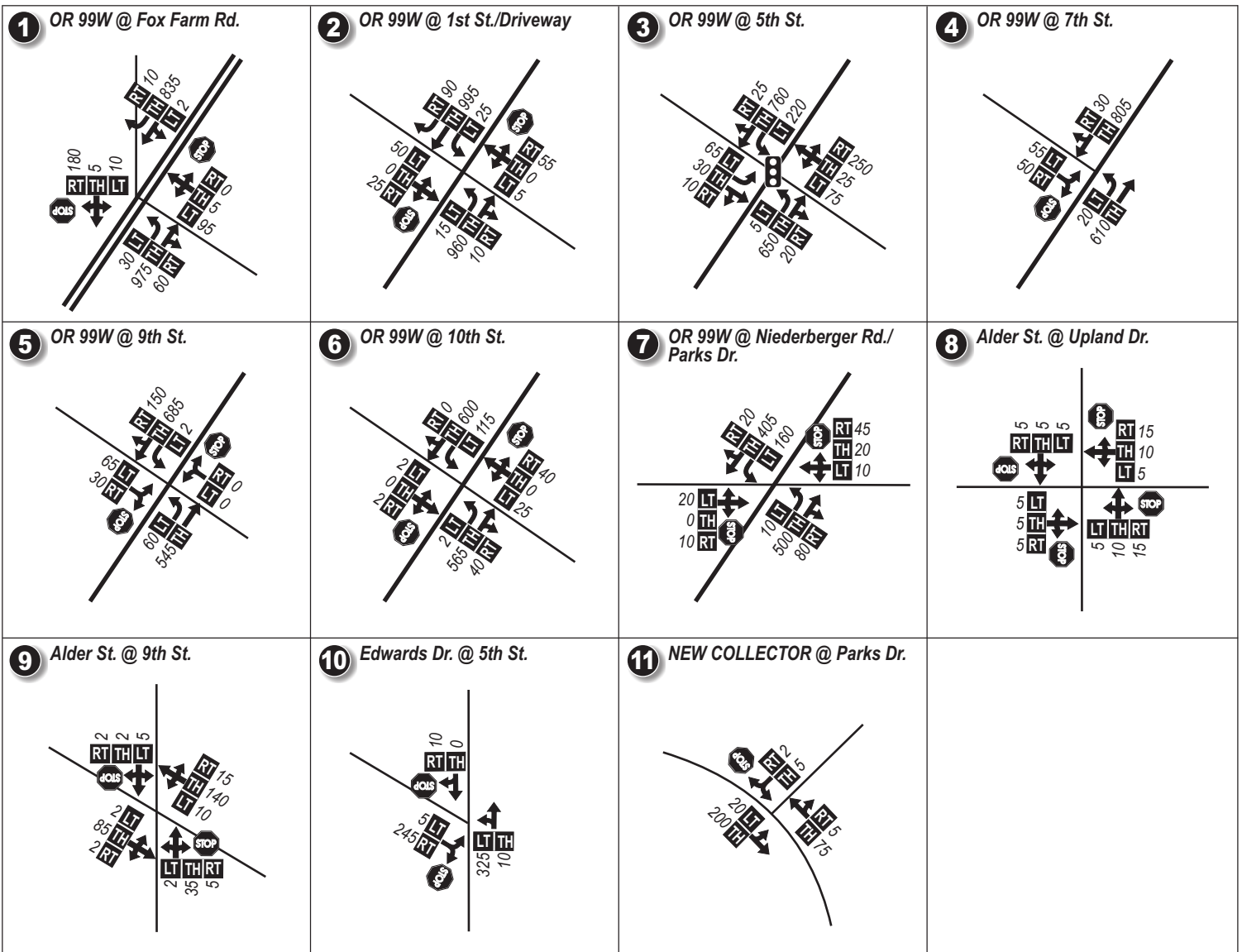
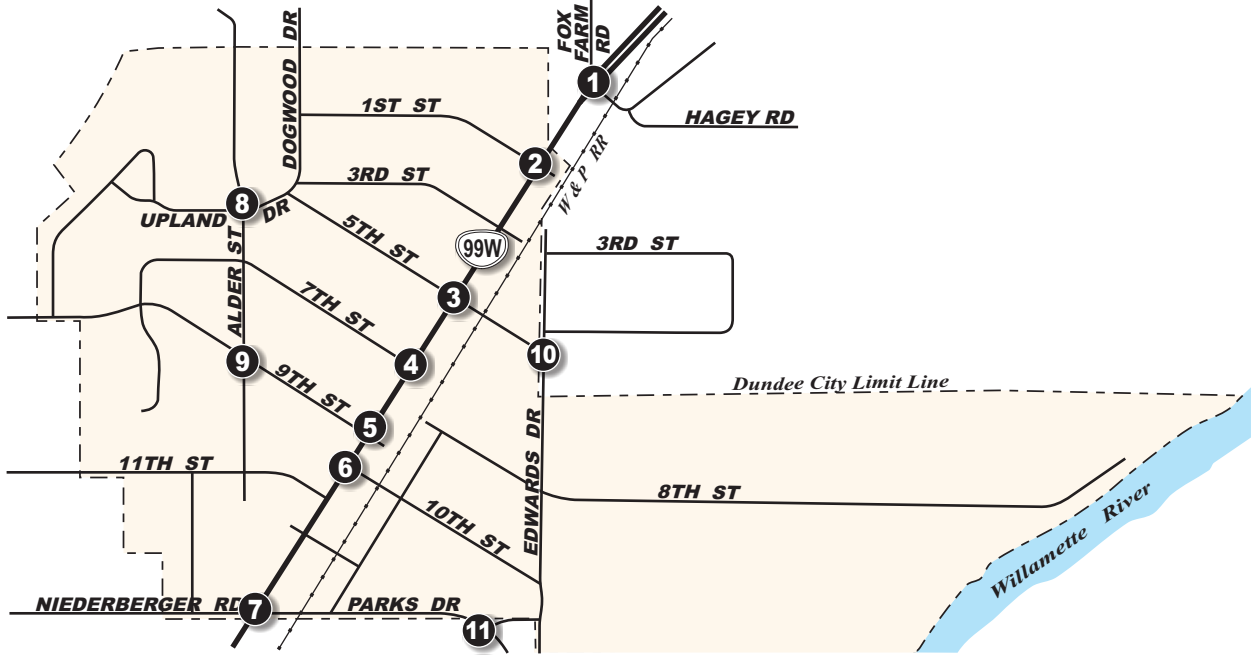

**LEGEND**

- 1** - Study Intersection
- Lane Configuration
- Stop Sign
- Traffic Signal
- 000 - PM Peak Hour Traffic Volumes
- Volume Turn Movement  
Left • Thru • Right

**DKS** Figure **2**

**YEAR 2035 AVERAGE WEEKDAY  
PM PEAK HOUR TRAFFIC VOLUMES**

Turning movement volumes were forecast for the 11 intersections that were analyzed in the Existing Conditions phase of this project. Other potentially important intersections, such as SE 8th Street/SE Edwards Drive and Highway 99W/SW 11<sup>th</sup> Street, may still be assessed using the detailed model developed for this forecasting process. For more information, see the section on model application to Dundee later in this memo.

### Newberg-Dundee Travel Demand Model

The Oregon Department of Transportation (ODOT) maintains a travel demand model that estimates daily and p.m. peak hour demand for the existing year and future year transportation system based on existing and forecast land uses, as well as other data and assumptions. The forecasting process for the Dundee TSP Update uses base year (2000) and future year (2035) models to estimate future traffic volumes. As part of the TSP update, the future model was updated from its previous 2025 horizon year to include projected 2035 land use. These models include two key elements that help estimate future traffic:

- **Transportation Analysis Zones (TAZs).** The model area is split into 131 TAZs. Each TAZ represent a small subarea of the model, and each has unique land use attributes that represent the number of households and the number and type of employees within the zone. These land use attributes determine the intensity and directionality of trips generated by the zone. The TAZ structure is shown in Figure 3.
- **Transportation Network.** The model maintained by TPAU includes a network of links that generally represent the major transportation system (collector road and above) in the model area. Each link is coded with attributes (e.g., speed and capacity) that approximate the function of existing roadways (for the base year and future year) and programmed roadway improvements (for the future year). Each TAZ is connected to links in the model at points that approximate where vehicles are expected to enter the network.

For the Dundee TSP forecasting, the significant programmed network change is the Phase 1 Newberg-Dundee Bypass, which provides a major alternate route for through traffic on Highway 99W that is not originating from or destined for areas in Dundee or central/western Newberg. Other network differences between the 2000 and 2035 models exist in the Newberg side of the model, and do not affect traffic volumes entering or exiting Dundee. Land use changes between the base year and future year are discussed in the next section.

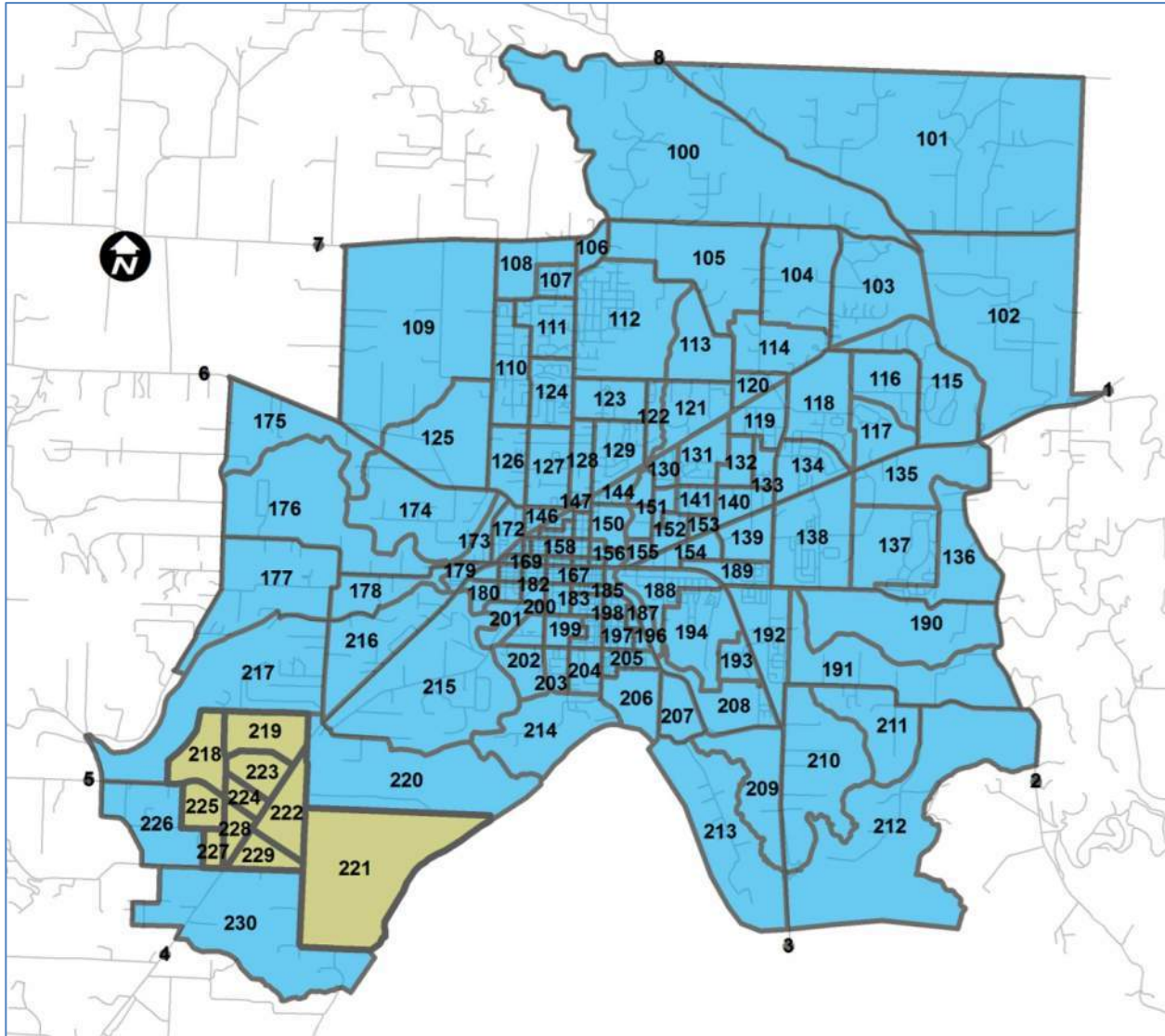

Figure 3: Newberg-Dundee Model TAZ Structure (Dundee TAZs in green)

## Projected Land Use Changes

Land use is a crucial factor in forecasting future transportation demand. The amount of land that is to be developed, the type and density of land uses, and how the land uses are arranged within the model area has a direct impact on the future system.

Projected land uses were developed for the model area, with the general development patterns based on the Comprehensive Plan designations for the Cities of Dundee and Newberg. The following resources were key in developing overall population and employment totals for the two cities as well as the unincorporated portions of Yamhill County that are included in the model:

- Yamhill County 20-year (2035) coordinated population projections (2012)
- Newberg Economic Opportunities Analysis (2012)
- Southeast Dundee Riverside Master Plan Market Study (2010)

These population and employment assumptions form the basis for the two travel demand model scenarios used for forecasting:

- **Base Year (2000):** The base year scenario, maintained by ODOT's Transportation Planning and Analysis Unit (TPAU), represents calibrated conditions for the year 2000.
- **Future Year (2035):** The previous future year scenario for Newberg-Dundee was 2025. This scenario was refined for this project to reflect anticipated 2035 land uses and growth within and outside the model area.

The next section summarizes the anticipated changes and growth within Newberg, Dundee, and the surrounding unincorporated areas that influence travel.

## Growth Within the Model Area

The Newberg-Dundee models generally use households and employment as a basis for estimating future transportation activity. Different types of employment are associated with different types of origin-destination intensities and patterns in the p.m. peak hour. For example, TAZs with large numbers of Service Employees may generate a heavy outbound travel movement, sending trips toward TAZs with more households. Conversely, TAZs with a lot of retail employees may attract trips in the p.m. peak hour. Table 1 summarizes how households and employment are assumed to change between the 2000 base year and 2035.

Table 1: Model Land Use Changes, 2000-2035

Land Use	2000	2035	% Increase
<b>Population</b>	23,062	44,289	92%
<b>Households</b>	8,313	16,397	97%
<b>Total Employment</b>	7,310	15,632	114%

Source: Newberg-Dundee Travel Demand Model



The land use changes between the base model year and the 2035 projections reflect efforts on the parts of both cities to improve the jobs-housing balance by increasing industrial and service (office, for example) employment locally. This means that more work trips may begin and end within the respective cities rather than would be expected without this improvement in the land use mix. Table 2, below, shows changes only within the model TAZs that fall within the Dundee urban growth boundary.

Table 2: Model Land Use Changes in Dundee, 2000-2035

Land Use	2000	2035	% Increase
<b>Population</b>	2,980	4,985	67%
<b>Households</b>	1,043	1,793	72%
<b>Total Employment</b>	180	1,049	483%

Source: Newberg-Dundee Travel Demand Model

This table reflects the City of Dundee’s recent effort to create more employment lands in the Riverside growth area between Highway 99W and the Willamette River. Development of the area as planned will likely lead to a significant improvement in the City’s jobs-housing balance. Figure 4 shows the relative growth of households and employment projected for Dundee TAZs. The majority of growth is projected to occur in the Riverside area (TAZ 221).

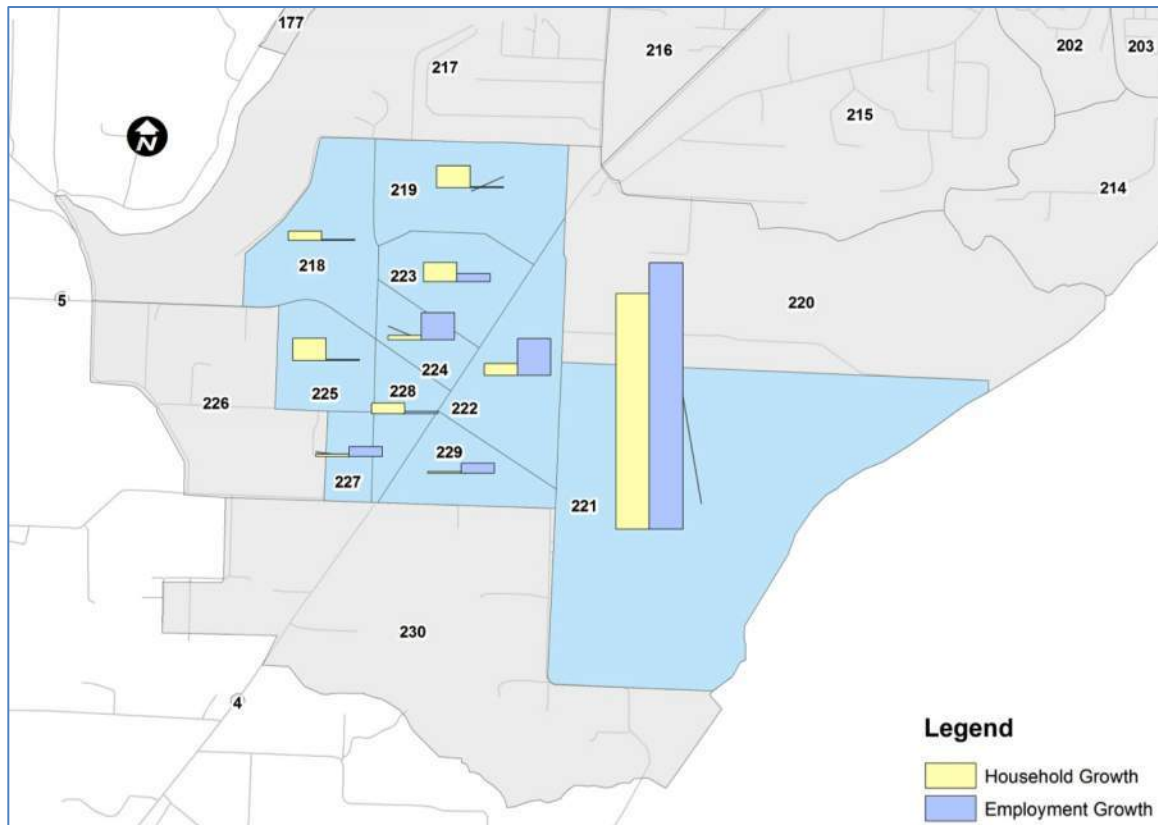

Figure 4: Relative growth and employment in Dundee TAZs

Table 1 and Table 2 show that the number of households in the model area nearly doubles and the number of employees more than doubles. Therefore, while the jobs-housing balance improves in the forecast year, the overall intensity of land use indicates that the transportation infrastructure needed to support this growth is significant. The programmed Phase 1 Newberg-Dundee Bypass is significant improvement that will help alleviate issues on the local transportation system. The TSP update processes for Dundee and Newberg will identify additional needs and help determine strategies and improvements for all modes based on the 2035 forecasts.

The overall growth in land uses was applied to individual TAZs with detailed input and review from staff at the cities of Newberg and Dundee.<sup>1</sup>

### Trip Generation

The model's trip generation process calculates the total number of productions (person-vehicle trips), per TAZ, by household attributes such as size, income, and number of workers. The Oregon Small Urban Model (OSUM) trip generation process is elaborate, entailing detailed trip characteristics for various types of housing, employment, and special activities. The model process is tailored to variations in travel characteristics and trip purposes in the region, including estimation of the likelihood for trip potential to be achieved for a particular land area.

The increase in households and employees in the model area mean an increase in the overall number of trips generated. Table 3 summarizes the total modeled 2000 and 2035 motor vehicle trips both model-wide, as well as the trips that begin or end in Dundee. The table shows that vehicle trips are expected to grow at a faster rate in Dundee than in the rest of the model area between 2000 and 2035 if the land develops according to the modeled land use assumptions. This relatively high expected increase in Dundee is the result of the significant future employment growth shown in Table 2. The employment growth is generally centered on the Riverside area (TAZ 221), and tends to result in outbound trips from the area that are mostly routed west on SE 5<sup>th</sup> Street and then north on Highway 99W.

**Table 3: Vehicle Trip Generation (PM Peak Hour)**

	2000 Trips	2035 Trips	% Increase
<b>Newberg-Dundee Model Area</b>	12,709	22,336	76%
<b>Dundee TAZs Only</b>	1,217	2,665	119%

Source: Newberg-Dundee Travel Demand Model

<sup>1</sup> Memoranda available upon request: *Buildable Lands, Population, and Employment Forecast for Dundee* (July 5, 2012) and *Population and Employment Capacity in UGB for the TSP* (August 2, 2012).

## Trip Distribution

This step estimates how many trips travel from one TAZ in the model to any other TAZ.

Distribution is based on the number of trip ends generated in each TAZ zone pair, and on factors that estimate the likelihood of travel between any two TAZs, such as travel time between the zones.

In projecting future traffic volumes, it is important to consider potential changes in regional travel patterns. Although the locations and amount of traffic generation in the Newberg-Dundee area are essentially a function of future land use in the city, the distribution of trips is influenced by expected congestion on roadways and regional growth, particularly in neighboring areas such as McMinnville, the Oregon Coast, and the Portland metropolitan area. The model and trip distribution can also be used to help define the number of internal, external and through trips for the model area. These types of trips are as follows:

- **Internal trips** (“i-i”) are trips that start and end within the model area
- **External trips** (“e-i” or “i-e”) are trips that either start in the model area and end outside it, or vice versa.
- **Through trips** (“e-e”) are trips that pass through the model area and have neither an origin nor a destination within it

Table 4 shows these three trip types for all modeled roadways in the Newberg-Dundee area as forecast in the model for 2000 and 2035.

Table 4: Model Vehicle Trip Distribution (PM peak hour)

Trip Type	2000	2035	Change
<b>Internal (i-i)</b>	55%	57%	+2%
<b>External (e-i or i-e)</b>	34%	33%	-1%
<b>Through (e-e)</b>	11%	10%	-1%

Source: Newberg-Dundee Travel Demand Model (trip matrices)

Modeling results show a slight increase in the proportion of trips both originating and ending within the model area. This is accompanied by a slight decrease in the proportion of trips beginning and/or ending outside the model area.

## Traffic Assignment

In this modeling process, trips from one zone to another are assigned to specific travel routes in the network, and resulting trip volumes are accumulated on links of the network until all trips are assigned. The route on which a trip is assigned generally depends on whether it offers the shortest travel time among all possible routes, given all the other trips on the network. Figure 5 provides an example of how the model applies trips traveling northbound and southbound between Newberg and Dundee in the base year and future year.

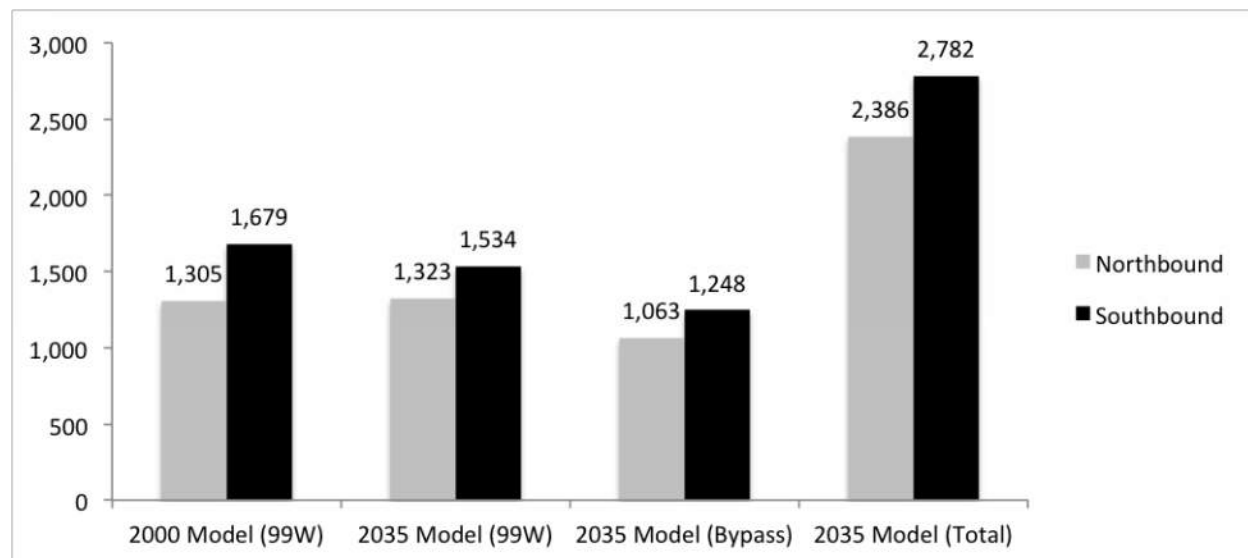

Figure 5: Traffic Volumes between Fox Farm Road and 1st Street, 2000 and 2035 (PM peak hour)

The figure shows that while there is significant growth in the number of trips passing between the two cities, each facility (Highway 99W and the bypass) carries a similar share. Significantly, the addition of the bypass results in lower demand on Highway 99W southbound in 2035 than exists in the base year, even though overall southbound demand is 55% higher (2,595 trips in 2035 compared to 1,679 trips in 2000).

### Model Application to Dundee

The 2000 and 2035 model and assignments were prepared and provided by TPAU. For the Dundee forecast, it was necessary to provide greater network detail in order to represent study intersections and key facilities that were not included in the base model through a “focus area” exercise. Adding the new network detail helps refine local circulation in Dundee without affecting routing in the overall regional model. This is because the network provides only one gateway into Dundee from the north (Highway 99W south of Fox Farm Road) and one gateway out of Dundee from the south (99W south of Niederberger Road). Links added to the network include:

- SW 3<sup>rd</sup> Street
- SW 7<sup>th</sup> Street
- SW 11<sup>th</sup> Street
- SE 8<sup>th</sup> Street
- SE Maple Street

The existing network in Dundee and the new links added are shown in the appendix to this memorandum.

Adding network detail also necessitated more detailed land use assumptions. Some TAZs in the Dundee side of the model were disaggregated (i.e., split into smaller zones). Trips (origin-destination pairs) generated by the original (“parent”) TAZs were reallocated to the smaller, disaggregated (“child”) TAZs. This reallocation was based on refined assumptions about how households and employees would be split among the smaller TAZs based on aerial photography and the developable land previously reviewed in the development of the updated 2035 scenario. A regression analysis was used to estimate the relative intensity and directionality of trips generated by these land uses. The equation generated by this analysis is shown below.

*Inbound trips*

$$= (.508 \times \text{households}) + (.643 \times \text{retail employees}) \\ + (.133 \times \text{all other employees})$$

*Outbound trips*

$$= (.160 \times \text{households}) + (.623 \times \text{retail employees}) \\ + (.312 \times \text{all other employees}) =$$

The total trips generated by the parent TAZs were used as a control, and kept consistent when reallocating to child TAZs (i.e., the number of trips estimated by the regression equations would be factored up or down TAZ-wide in order to match the parent TAZ total). A table showing the trips for both the parent TAZs and child TAZs is shown at the end of this memo.

As parent TAZs were split into child TAZs, connections from the new TAZs to the model network were determined through a review of aerial photography. This review took into account where existing land uses currently access the transportation network, and where future land uses are likely to access the network. This exercise was performed for both the 2000 and 2035 scenarios, and new traffic assignments were run for the two scenarios, providing base and future volumes for the forecasting process. The assignments for the focus area exercise were compared to the assignments provided by TPAU in order to ensure consistency of traffic volumes entering and exiting the focus area at two key locations on Highway 99W: (1) just north of 1<sup>st</sup> Street, and (2) just south of Niederberger Road. These volumes are shown in Table 5.

Table 5: Control gateway volumes for focus area

Location and Direction	2000 Scenario (Original regional model)	2000 Scenario (Focus Area model)	2035 Scenario (Original regional model)	2035 Scenario (Focus Area model)
<b>99W between Fox Farm and 1<sup>st</sup>, northbound</b>	1,304	1,304	1,339	1,339
<b>99W between Fox Farm and 1<sup>st</sup>, southbound</b>	1,679	1,679	1,531	1,531
<b>99W south of Niederberger, northbound</b>	992	992	558	558
<b>99W south of Niederberger, southbound</b>	991	991	358	358

Source: Newberg-Dundee Travel Demand Model, Focus Area Model

PM peak hour volumes were extracted from the model for both the base year (2000) and forecast year (2035) scenarios. A “post processing” technique following NCHRP 255 Methodology<sup>2</sup> was utilized to refine model travel forecasts to the volume forecasts presented in Figures 1 and 2. Post processing is a methodology that uses existing traffic volumes<sup>3</sup>, base year model data, and future year model data to help determine future volumes.

Because the increment between the model base year and future year (35 years) is larger than the increment between the base count year (2012) and planning horizon year (2035) (23 years), this analysis considered using an increment smaller than the full 35 year model growth. However, a comparison of base year model volumes and 2012 traffic volumes showed that in most cases the volumes are either very similar, or the 2000 model shows higher volumes. A sample of this comparison for Dundee is shown in Table 6.

Table 6: Comparison of 2000 model and 2012 existing volumes (PM peak hour)

Location and Direction	2000 Base Scenario	2012 Peak Seasonal
<b>99W between Fox Farm and 1<sup>st</sup>, northbound</b>	1,304	1,135
<b>99W between Fox Farm and 1<sup>st</sup>, southbound</b>	1,679	1,365
<b>99W south of Niederberger, northbound</b>	992	1,040
<b>99W south of Niederberger, southbound</b>	991	1,060

Source: Newberg-Dundee Travel Demand Model, Dundee TSP Update Existing Conditions Memo

<sup>2</sup> Highway Traffic Data for Urbanized Area Project Planning and Design - National Cooperative Highway Research Program Report 255, Transportation Research Board, Washington D.C., 1982.

<sup>3</sup> See the Existing Conditions project memo for more information on existing year (2012) traffic counts and the seasonal adjustment done to create peak seasonal and average annual volume sets.



This overall flat trend in travel patterns is typical of many planning studies done in recent years, and most likely reflects the effects of the recession on economic development and employment-related travel. Therefore, the traffic volumes observed under existing conditions are assumed to be a close match to the volumes modeled in the 2000 base year. However, because the future volume forecasts are still intended to reflect the projected land uses for 2035, this analysis assumes the full growth increment between the base year and future year models.

### Appendix: Focus Area Method

This appendix provides additional detail on how the Newberg-Dundee travel demand model was refined for the Focus Area exercise. Included are figures showing enhancements to the model network and TAZ structure, and a table showing how trips were reallocated from the original, larger model (parent) TAZs to the smaller, disaggregated (child) TAZs.

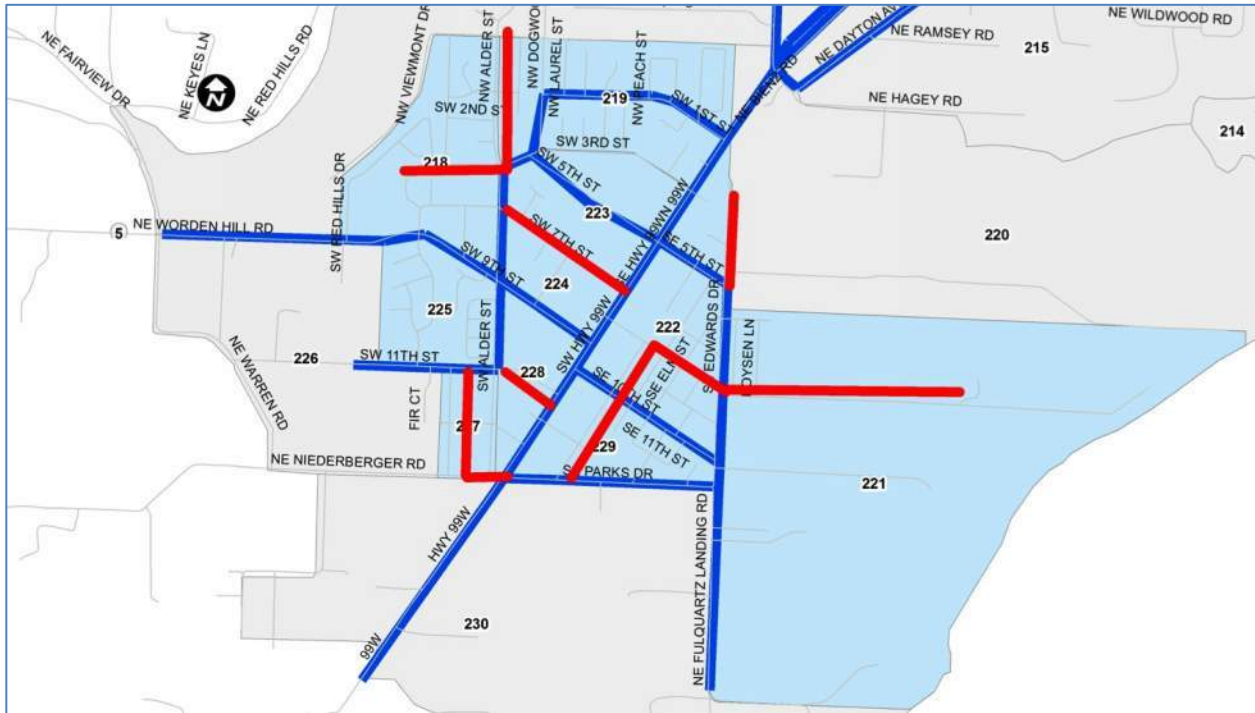

Figure 6: Refined network for Focus Area exercise (network refinements in red)

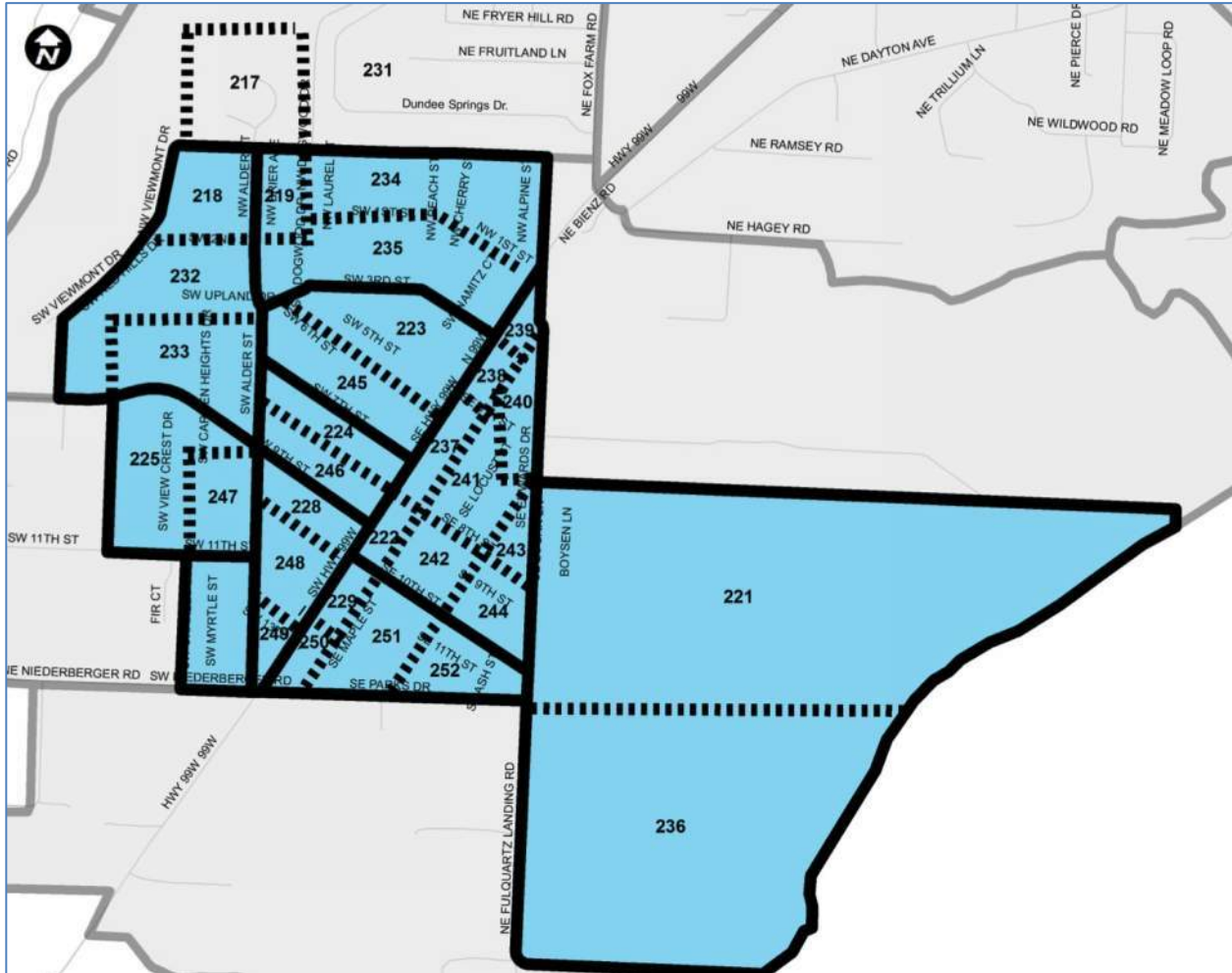

Figure 7: Refined TAZ structure used for Focus Area exercise (TAZs refined from original model shown by dashed lines)

Table 7: Land use and trips for Focus Area TAZs (2000 PM peak hour)

New TAZ	HH	EMPBASE	Factored Trips In	Factored Trips Out
<b>217</b>	<b>40</b>	<b>3</b>	<b>28.8</b>	<b>8.9</b>
217	17		12.0	3.3
231	23	3	16.8	5.6
<b>218</b>	<b>142</b>	<b>3</b>	<b>97.4</b>	<b>24.3</b>
218	47		32.1	7.7
232	47		32.1	7.7
233	48	3	33.3	8.8
<b>219</b>	<b>187</b>	<b>3</b>	<b>129.8</b>	<b>32.8</b>
219	22		15.2	3.7
234	65		44.9	11.1
235	100	3	69.7	18.0
<b>220</b>	<b>18</b>	<b>7</b>	<b>15.8</b>	<b>8.6</b>
<b>221</b>	<b>54</b>	<b>0</b>	<b>36.2</b>	<b>7.9</b>
221	50		33.5	7.3
236	4		2.7	0.6
<b>222</b>	<b>149</b>	<b>18</b>	<b>111.2</b>	<b>38.8</b>
222	0	3	0.6	1.2
237	0	3	0.6	1.2
238	0	3	0.6	1.2
239	0	3	0.6	1.2
240	10	2	7.6	2.9
241	20	2	14.8	5.0
242	20	2	14.8	5.0
243	35	0	25.3	7.4
244	64	0	46.3	13.5

New TAZ	HH	EMPBASE	Factored Trips In	Factored Trips Out
<b>223</b>	<b>33</b>	<b>42</b>	<b>41.2</b>	<b>128.2</b>
223	10	37	33.9	123.0
245	23	5	7.2	5.1
<b>224</b>	<b>72</b>	<b>15</b>	<b>59.8</b>	<b>25.7</b>
224	48	10	39.9	17.1
246	24	5	19.9	8.6
<b>225</b>	<b>120</b>	<b>5</b>	<b>84.9</b>	<b>22.7</b>
225	90	5	63.9	17.4
247	30	0	21.0	5.2
<b>226</b>	<b>34</b>	<b>39</b>	<b>40.1</b>	<b>34.8</b>
227	58	3	41.6	11.5
<b>228</b>	<b>40</b>	<b>5</b>	<b>29.9</b>	<b>11.0</b>
228	10	0	7.2	2.2
248	30	0	21.7	6.7
249	0	5	0.9	2.2
<b>229</b>	<b>65</b>	<b>53</b>	<b>67.4</b>	<b>52.0</b>
229	0	12	2.7	7.2
250	0	12	2.7	7.2
251	10	29	15.0	20.5
252	55	0	47.0	17.0
<b>230</b>	<b>31</b>	<b>0</b>	<b>21.2</b>	<b>4.4</b>

**Shaded, bold** TAZs are “parent” TAZs from the original regional model

“Child” TAZs are listed below each parent TAZ, with land use and calculated trips adding up to match the parent TAZ’s control total.

Table 8: Land use and trips for Focus Area TAZs (2035 PM peak hour)

New TAZ	HH	EMPBASE	Factored Trips In	Factored Trips Out
<b>217</b>	<b>78</b>	<b>48</b>	<b>63.0</b>	<b>39.9</b>
217	35		24.3	8.1
231	43	48	38.7	31.8
<b>218</b>	<b>162</b>	<b>5</b>	<b>100.7</b>	<b>26.3</b>
218	54		33.3	8.3
232	54		33.3	8.3
233	54	5	34.1	9.8
<b>219</b>	<b>236</b>	<b>5</b>	<b>148.4</b>	<b>39.1</b>
219	60		37.5	9.5
234	70		43.8	11.1
235	106	5	67.1	18.4
<b>220</b>	<b>24</b>	<b>8</b>	<b>17.8</b>	<b>8.4</b>
<b>221</b>	<b>578</b>	<b>592</b>	<b>576.6</b>	<b>465.8</b>
221	295	592	400.0	403.0
236	283		176.6	62.8
<b>222</b>	<b>175</b>	<b>100</b>	<b>140.6</b>	<b>86.2</b>
222	0	15	2.7	6.8
237	0	20	3.7	9.1
238	0	15	2.7	6.8
239	0	20	3.7	9.1
240	10	10	8.8	6.9
241	40	10	29.8	13.9
242	25	10	19.3	10.4
243	35	0	24.5	8.2
244	65	0	45.4	15.2



New TAZ	HH	EMPBASE	Factored Trips In	Factored Trips Out
<b>223</b>	<b>76</b>	<b>60</b>	<b>66.4</b>	<b>218.0</b>
223	20	53	24.5	139.3
245	56	7	41.9	78.7
<b>224</b>	<b>82</b>	<b>75</b>	<b>86.3</b>	<b>66.0</b>
224	52	40	53.0	37.6
246	30	35	33.3	28.4
<b>225</b>	<b>170</b>	<b>8</b>	<b>108.9</b>	<b>29.5</b>
225	125	8	80.4	22.3
247	45	0	28.5	7.2
<b>226</b>	<b>40</b>	<b>46</b>	<b>38.6</b>	<b>31.3</b>
<b>227</b>	<b>64</b>	<b>25</b>	<b>50.9</b>	<b>26.1</b>
<b>228</b>	<b>63</b>	<b>10</b>	<b>42.9</b>	<b>16.5</b>
228	20	0	13.1	4.0
248	43	0	28.1	8.6
249	0	10	1.7	3.9
<b>229</b>	<b>69</b>	<b>75</b>	<b>65.7</b>	<b>53.3</b>
229	0	15	2.9	7.2
250	0	15	2.9	7.2
251	10	45	16.1	24.2
252	59	0	43.7	14.6
<b>230</b>	<b>41</b>	<b>25</b>	<b>32.8</b>	<b>18.6</b>

**Shaded, bold** TAZs are “parent” TAZs from the original regional model

“Child” TAZs are listed below each parent TAZ, with land use and calculated trips adding up to match the parent TAZ’s control total.

# MEMORANDUM #6

**DATE:** October 1, 2013

**TO:** Dundee TSP Update Project Management Team

**FROM:** Carl Springer, P.E., DKS Associates  
Ray Delahanty, AICP, DKS Associates  
Anastasia Roeszler, E.I., DKS Associates

**SUBJECT: Dundee Transportation System Plan Update  
Future Needs Analysis**

---

This memorandum describes transportation conditions in Dundee in 2035 if no new investments, other than those already funded, are made to the existing transportation system. Included is a summary of how future transportation demand is determined, a depiction of what travel in 2035 is projected to look like in Dundee, and a discussion of where transportation investments are needed. This memo also includes an outline of potential improvements to consider as alternatives are developed for the next phase of the Transportation System Plan (TSP).

## Estimating Future Travel

A determination of future transportation system needs in Dundee requires the ability to accurately forecast travel demand from estimates of future population and employment, and forecast travel patterns based on decisions and preferences demonstrated by existing residents and travelers through the region. Travel demand models help forecast future commuter, school, and other travel patterns, including estimates of the length and time of day a trip will be made. Comparing model outputs with counts and patterns observed on the existing system helps to refine model forecasts. This refinement step is completed before any evaluation of system performance is made. Once the traffic forecasting process is complete, the 2035 volumes are analyzed to determine the areas of the street network that are expected to be congested and that may need future investments to accommodate growth.

This process takes into account the existing network as well as any programmed future improvements. For the Dundee TSP forecasting, the significant programmed network change is the Phase I Newberg-Dundee Bypass (shown in Figure 1), which provides a major alternate route for through traffic on Highway 99W that is not originating from or destined for areas in Dundee or central/western Newberg.



Figure 1: The Phase 1 Newberg Dundee Bypass is the only programmed capacity improvement in the Dundee area

## How Do We Determine Future Transportation System Demand?

The first step in identifying future needs is to estimate future demand on the transportation system. The Oregon Department of Transportation (ODOT) maintains a travel demand model that estimates daily and p.m. peak hour demand for the existing year and future year transportation system in the Newberg-Dundee area based on existing and forecast land uses, as well as other data and assumptions.<sup>1</sup> The forecasting process for the Dundee TSP Update uses base year (2000) and future year (2035) models to estimate future traffic volumes. As part of the TSP update, the future model was updated from its previous 2025 horizon year to include projected 2035 land use. These models include two key elements that help estimate future traffic:

- **Transportation Analysis Zones (TAZs).** The Newberg-Dundee model area is split into 131 TAZs. Each TAZ is described by the number of households and the number and type of employees within the zone. The type and intensity of the land uses determines the scale and directionality of trips generated by the zone.
- **Transportation Network.** The model includes a network of links that generally represent the major transportation system (City and County collector and arterial roads and the state highway facilities) in the model area. Each link is coded with attributes (e.g., speed and capacity) that approximate the function of existing roadways and programmed roadway improvements (for the future year). Each TAZ is connected to links in the model at points that approximate where vehicles are expected to enter the network.

<sup>1</sup> For more detail on the forecasting process, see this project's Technical Memorandum #5, Future Forecasting.

The following sections explain where growth is expected, how the transportation system may be affected, and where solutions will be needed. Alternatives for addressing the transportation system needs will be explored in Technical Memorandum #7.

### Dundee in 2035

Today, Dundee is home to over 3,100 residents but only around 200 jobs. Between now and 2035, population is expected to grow significantly, and employment growth is expected to increase dramatically. By 2035, Dundee is expected to be home to about 5,000 residents and 1,050 jobs, an increase of 61% and 425% respectively from today. With more people and more jobs in Dundee, the transportation network will face increased local demand through 2035.

### Growing Population and Employment

As shown in Figure 2, much of the population and employment growth is expected to occur in the Riverside area (TAZ 221). This is the result of the City of Dundee’s recent effort to create more employment lands in the Riverside growth area between Highway 99W and the Willamette River. Development of the area as planned will likely lead to a significant improvement in the City’s jobs-housing balance.

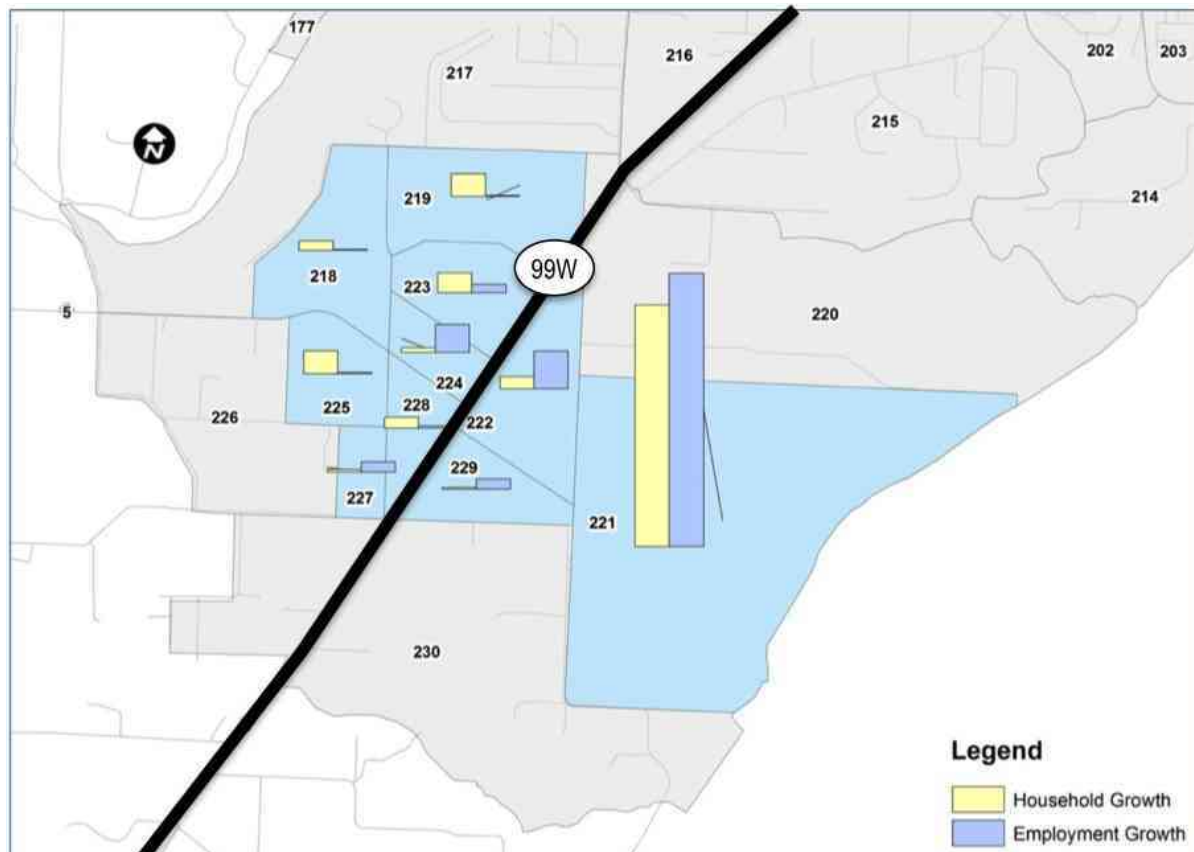

Figure 2: Relative Growth and Employment in Dundee TAZs

### Change in Travel Patterns

With the forecast increase in population and employment in Dundee, the transportation infrastructure needed to support growth is significant. The programmed Phase 1 Newberg-Dundee Bypass is a key improvement that will generally serve traffic passing through the Newberg-Dundee area, likely alleviating issues on the local transportation system. The 2035 model shows that about 80-90% of this “through” traffic, which currently uses Highway 99W, will use the Bypass instead.

The increase in households and employees through 2035 mean an increase in the overall number of trips generated. Table 1 shows the change in PM peak hour trips estimated by the Newberg-Dundee model within Dundee, and within the entire model area. The table shows that trips are expected to grow at a faster rate in Dundee than in the rest of the model area between 2000 and 2035 if the land develops according to the model’s land use assumptions.

**Table 1: Vehicle Trip Generation (PM Peak Hour)**

	2000 Trips	2035 Trips	% Increase
<b>Newberg-Dundee Model Area</b>	12,709	22,336	76%
<b>Dundee TAZs Only</b>	1,217	2,665	119%

Source: Newberg-Dundee Travel Demand Model

Forecast 2035 p.m. peak hour volumes representing the 30<sup>th</sup> highest hour (or design hour) and the average weekday are shown in Figures 3 and 4.



NO SCALE

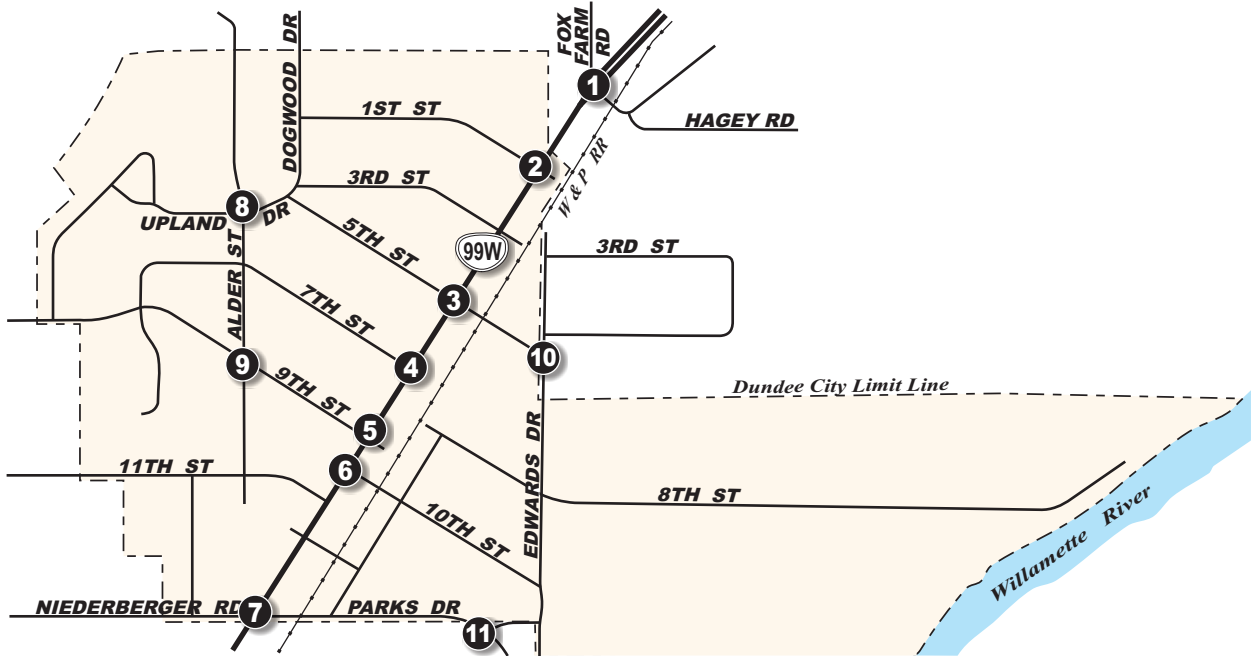

1 OR 99W @ Fox Farm Rd.

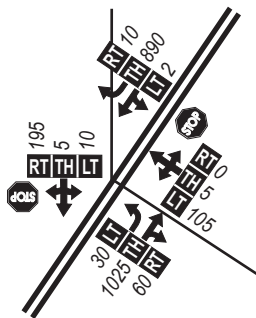

2 OR 99W @ 1st St./Driveway

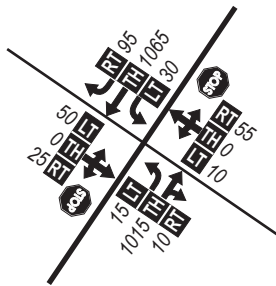

3 OR 99W @ 5th St.

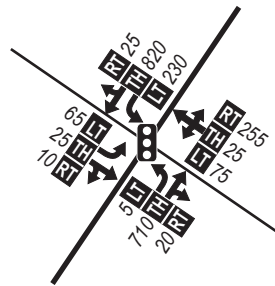

4 OR 99W @ 7th St.

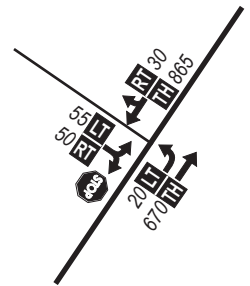

5 OR 99W @ 9th St.

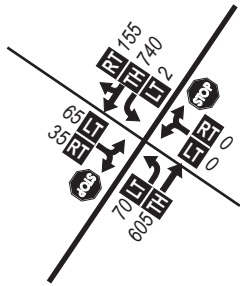

6 OR 99W @ 10th St.

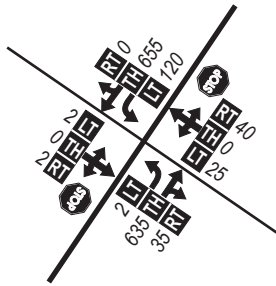

7 OR 99W @ Niederberger Rd./ Parks Dr.

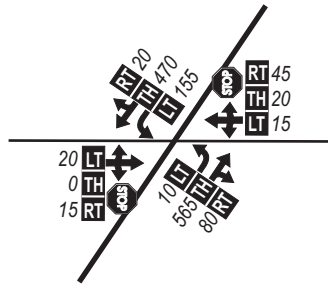

8 Alder St. @ Upland Dr.

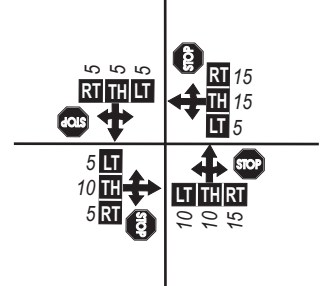

9 Alder St. @ 9th St.

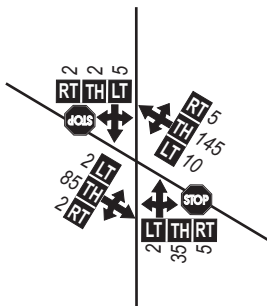

10 Edwards Dr. @ 5th St.

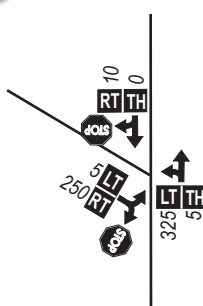

11 NEW COLLECTOR @ Parks Dr.

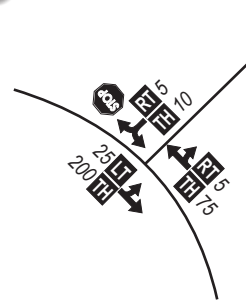

**LEGEND**

- 1 - Study Intersection
- STOP - Stop Sign
- Traffic Signal
- ← - Lane Configuration
- 000 - PM Peak Hour Traffic Volumes
- LT TH RT - Volume Turn Movement (Left-Thru-Right)

**DKS**

Figure **3**

**YEAR 2035 30HV  
PM PEAK HOUR TRAFFIC VOLUMES**





NO SCALE

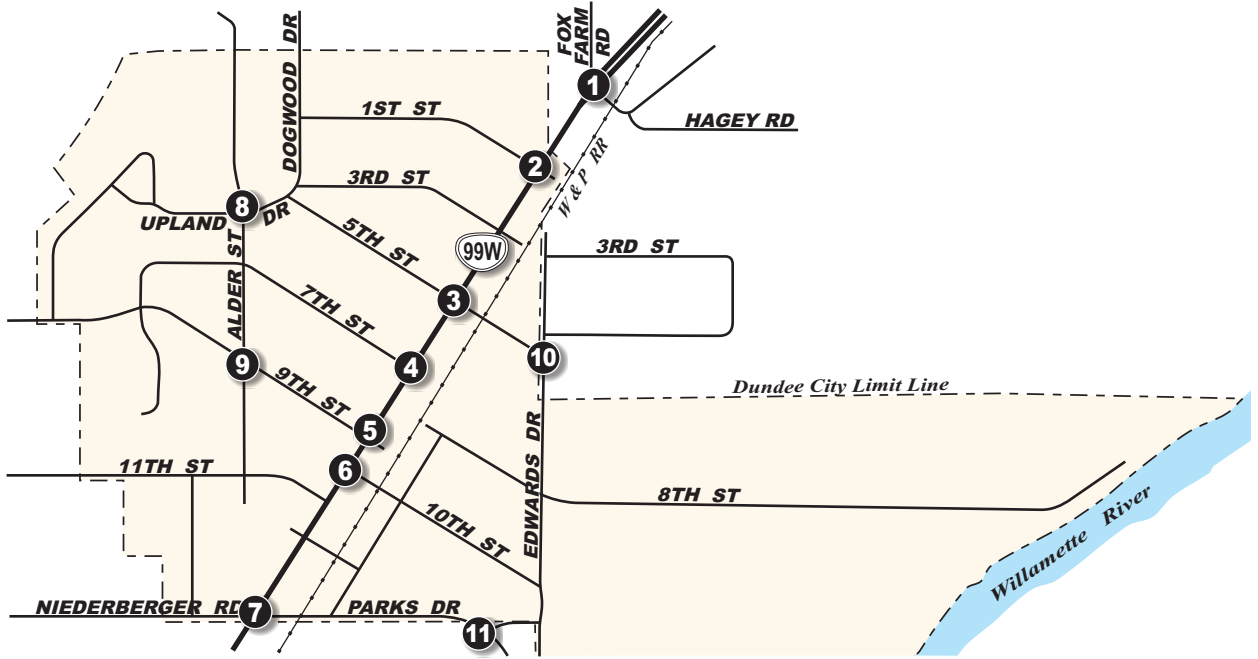

**1** OR 99W @ Fox Farm Rd.

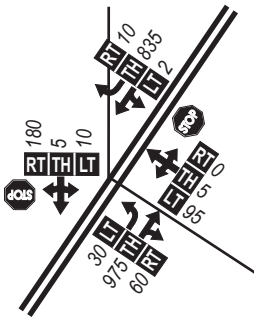

**2** OR 99W @ 1st St./Driveway

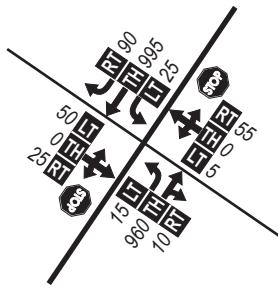

**3** OR 99W @ 5th St.

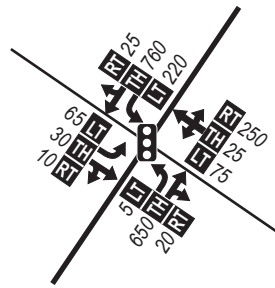

**4** OR 99W @ 7th St.

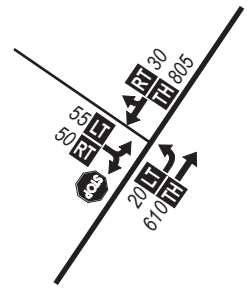

**5** OR 99W @ 9th St.

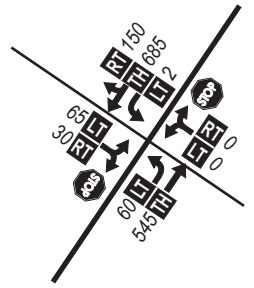

**6** OR 99W @ 10th St.

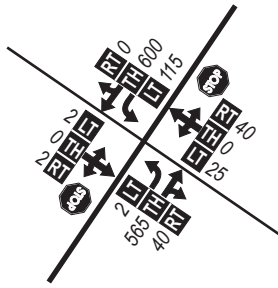

**7** OR 99W @ Niederberger Rd./Parks Dr.

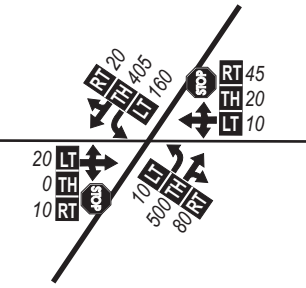

**8** Alder St. @ Upland Dr.

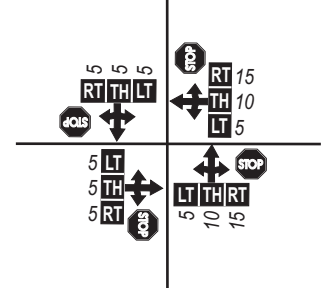

**9** Alder St. @ 9th St.

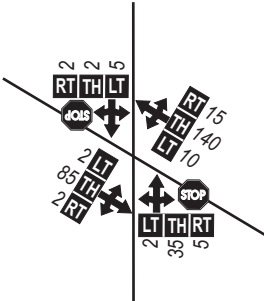

**10** Edwards Dr. @ 5th St.

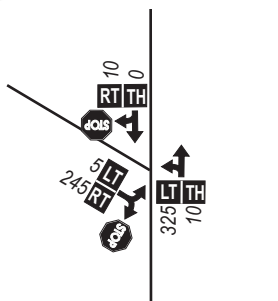

**11** NEW COLLECTOR @ Parks Dr.

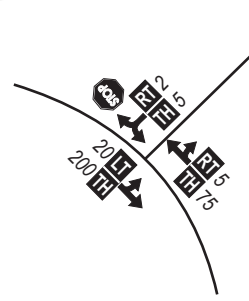

**LEGEND**

- 1** - Study Intersection
- Lane Configuration
- Stop Sign
- Traffic Signal
- 000 - PM Peak Hour Traffic Volumes
- LT TH RT** - Volume Turn Movement  
Left • Thru • Right



## How Will Changes Affect Traffic Congestion in Dundee?

Existing conditions analysis showed that significant traffic congestion and vehicle queuing exist in Dundee today.<sup>2</sup> While traffic is expected to increase in the Dundee area over the planning horizon, the Newberg-Dundee bypass is expected to divert much of the through traffic away from Highway 99W. Therefore, the overall effect of the increased local traffic resulting from higher population and employment in Dundee is largely offset by the decrease in through traffic due to the

bypass. Figure 5 shows the overall percent change in traffic along 99W between 2012 and 2035, considering the total entering volume (TEV) at each study intersection.

The reduction in volumes is small (5-8%) on Highway 99W at 5th Street and intersections to the north, while the reduction is much more significant (23-35%) south of 5th Street. This is due to the strong connection between new development (households and employment) in the Riverside area and likely commute-related destinations to the north, in Newberg and the Portland metropolitan area. Trips between the Riverside area and points north are most likely to use 5th Street intersection, although some may use 10th Street or Parks Drive.

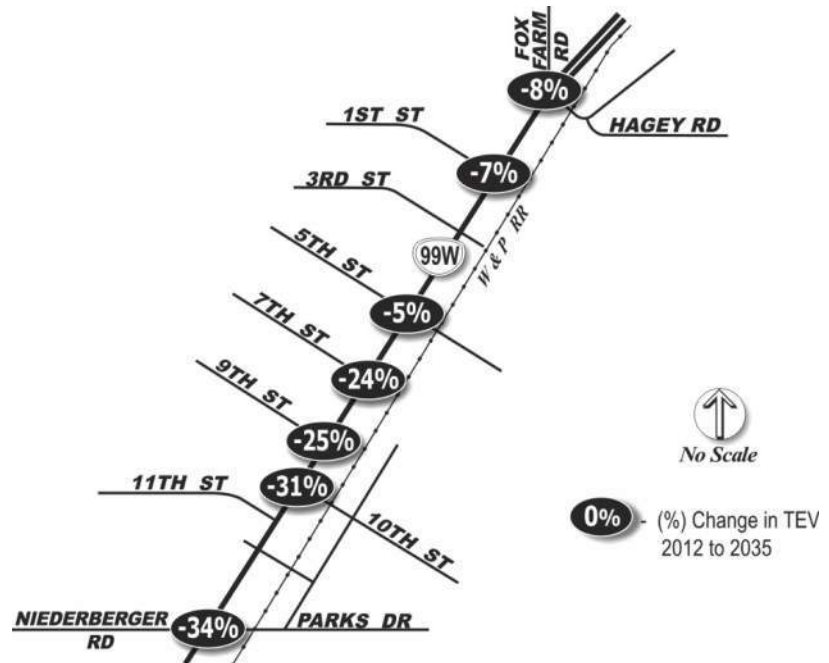

**Figure 5: Forecast reduction in traffic volumes on Highway 99W (30<sup>th</sup> highest hour) between 2012 and 2035, after the Phase 1 Bypass is operational.**

<sup>2</sup> See this project's Technical Memorandum #4, Existing Conditions.

## Motor Vehicle Operations

Intersections in Dundee are evaluated according to mobility targets, helping to identify and maintain a minimum level of efficiency for motor vehicle travel.<sup>3</sup> Two methods to gauge intersection operations include volume-to-capacity (v/c) ratios and level of service (LOS).

**Volume-to-capacity (V/C) ratio:** A decimal representation (with 1.00 representing saturated condition) of the proportion of capacity that is being used at a turn movement, approach leg, or intersection. It is determined by dividing the peak hour traffic volume by the hourly capacity of a given intersection or movement. A lower ratio indicates smooth operations and minimal delays. As the ratio approaches 1.00, congestion increases and performance is reduced. If the ratio is greater than 1.00, the turn movement, approach leg, or intersection is oversaturated and usually results in excessive queues and long delays. ODOT mobility targets for intersections along Highway 99W are based on v/c ratios. For a Freight Route on a Statewide Highway with a posted speed of 30 mph inside the Dundee UGB, the v/c standard is 0.85.<sup>4</sup>

**Level of service (LOS):** A “report card” rating (A through F) based on the average delay experienced by vehicles at the intersection. LOS A, B, and C indicate conditions where traffic moves without significant delays over periods of peak hour travel demand. LOS D and E are progressively worse operating conditions. LOS F represents conditions where average vehicle delay has become excessive and traffic is highly congested. LOS is used to designate minimum performance standards for intersections under City of Dundee and Yamhill County jurisdictions.

The motor vehicle conditions in Dundee vary based on the time of year. Operations at the 11 study intersections, shown in Table 2, were evaluated for the p.m. peak hour using the 2035 volume forecasts for both the peak seasonal period and average weekday. Mobility targets for each intersection are shown as well.

---

<sup>3</sup> For more information on mobility targets and operational analysis, see this project’s Technical Memorandum #4, Existing Conditions.

<sup>4</sup> See Oregon Highway Plan Policy 1F Revisions adopted December 21, 2011 (<http://www.oregon.gov/ODOT/TD/TP/docs/ohp11/policyadopted.pdf>)

Table 2: Intersection Operations (2035 PM peak)

Intersection	Mobility Target	Approach	Peak Seasonal		Average Weekday	
			V/C Ratio	LOS	V/C Ratio	LOS
<b>Signalized Intersections</b>						
Highway 99W/5 <sup>th</sup> Street	0.85	-	<b>0.91</b>	D	<b>0.86</b>	D
<b>Unsignalized Intersections*</b>						
Highway 99W/Fox Farm Road	0.85	WBL NBT	<b>&gt; 1.0</b> <i>0.66</i>	<b>F</b> -	<b>&gt; 1.0</b> <i>0.63</i>	<b>F</b> -
Highway 99W/1 <sup>st</sup> Street	0.85	EBL SBT	0.50 <i>0.65</i>	<b>E</b> -	0.44 <i>0.60</i>	<b>E</b> -
Highway 99W/7 <sup>th</sup> Street	0.85	EBL SBT	0.38 <i>0.55</i>	C -	0.34 <i>0.52</i>	C -
Highway 99W/9 <sup>th</sup> Street	0.85	EBL SBT	0.38 <i>0.55</i>	D -	0.33 <i>0.52</i>	C -
Highway 99W/10 <sup>th</sup> Street	0.85	WBL NBT	0.22 <i>0.41</i>	C -	0.19 <i>0.37</i>	C -
Highway 99W/Niederberger Road	0.85	WBL NBT	0.26 <i>0.40</i>	C -	0.22 <i>0.36</i>	C -
Upland Drive/Alder Street	D	NBT	0.04	A	0.04	A
9 <sup>th</sup> Street/Alder Street	D	NBT	0.08	B	0.08	B
5 <sup>th</sup> Street/Edwards Street**	D	EBR	0.28	A	0.27	A
Parks Drive/Edwards Street	D	WBL	0.02	B	0.01	A

Intersections not meeting the mobility standard are shaded in **black**.

\* V/C ratio reported for worst minor street approach and *worst Highway 99W approach (in italics)*, where applicable. LOS reported for worst minor street approach only.

\*\* Intersection configuration not allowed in HCM analysis, therefore intersection configuration was modified to allow for capacity analysis.

## Where Are Transportation Solutions Needed?

This section describes where transportation system deficiencies have been identified through future analysis as well the previous existing conditions work. Areas addressed include motor vehicle, walking, biking, transit, and other potential areas of transportation deficiency.

### Motor Vehicle Capacity Needs

Operational analysis shows that two intersections on Highway 99W fail to meet the ODOT mobility target in the future under both peak seasonal and average weekday conditions.

- **5<sup>th</sup> Street/Highway 99W.** While this intersection sees a reduction in total entering volume compared to 2012 conditions (see Figure 2), it still fails to meet the mobility target under forecast 2035 conditions, both for peak season and average weekday. This is primarily due to a significantly higher southbound left turn volume from 99W, bound for the Riverside area. This higher left turn volume means the protected left turn phase (solid green arrow) lasts longer, and there is less green time available for other signal phases.
  - **Potential Southbound Queuing.** Significantly more vehicles are expected to make a southbound left turn in 2035 than do today. At the same time, northbound through traffic is project to decline, so there may be more gaps in traffic for permitted southbound left turns. As the Riverside area develops, the intersection should be monitored for adequacy of vehicle storage for this movement.
  - **Potential Westbound Queuing.** Significantly more vehicles are expected to make a westbound right turn in the future, due to growth in the Riverside area. Queues that extend back to the railroad tracks (about 200 feet, or eight vehicles) will become more frequent if no improvements are made to the approach.
- **1<sup>st</sup> Street/Highway 99W.** This intersection meets the ODOT mobility target for Highway 99W, but does not meet the City LOS standard at its eastbound approach for either peak seasonal or average weekday conditions. In the future, about 50 vehicles are forecast to turn left onto Highway 99W from the west side of the highway, but similar to today, there are forecast to be few gaps in traffic for these left turning vehicles. This is projected to result in average delays of 40-50 seconds for left turning vehicles.
- **Fox Farm Road/Highway 99W.** This intersection is forecast to operate similarly to existing conditions. The westbound approach (from NE Dayton Avenue) is likely to experience significant delay, with around 100 vehicles attempting a left turn onto Highway 99W in the PM peak hour.

No operational issues were identified at local street intersections. See the Connectivity Needs and Safety Needs sections below for more discussion of local intersections.

### Alternative Mobility Targets

Mobility targets are typically based on 30<sup>th</sup> highest hour traffic volumes, in this case represented in the peak seasonal analysis shown in Table 2. ODOT also provides avenues for exploring alternative mobility targets, which are typically less difficult to meet. One approach to alternative targets is to analyze operations under traffic conditions that are less intense than the 30<sup>th</sup> highest hour, such as the average weekday p.m. peak hour.

While future traffic analysis shows somewhat better operations under average weekday conditions, the difference is not significant enough to allow the Fox Farm Road or 5<sup>th</sup> Street intersections to meet the 0.85 v/c target. Therefore, using average weekday operations to inform potential alternative mobility targets does not appear beneficial.

### Connectivity Needs

The ability to travel between different parts of the city conveniently is an important part of system planning as well. The following issues have been identified for Dundee under future conditions:

- The connection/route from Highway 99W to the Riverside area, including the Bypass overcrossing, will need to be determined in more detail as part of this TSP. It will be important to provide a relatively direct route that minimizes traffic impacts on local residential streets.
- Currently, Highway 99W is the only facility that serves trips between Dundee and points north. There may be options for creating additional connections, particularly for non-motorized travel. A potential Edwards Drive-Dayton Avenue connection is an example.
- 5<sup>th</sup> Street and Niederberger Road/Parks Drive are the only streets that offer a direct connection between the east and west sides of Dundee. All other streets have “T” connections with Highway 99W, requiring vehicles to turn onto the highway and then turn off in order to connect to the other side of the city.

### Safety Needs

As noted in the existing conditions phase, Highway 99W through Dundee (mile points 25.53 to 26.46) has a higher collision rate than the statewide average for similar facilities, with intersections at 1<sup>st</sup> Street, 5<sup>th</sup> Street, and 9<sup>th</sup> Street having the highest collision rates on the segment. 2035 traffic volumes on 99W are expected to drop compared to 2012 volumes due to the Bypass, while traffic volumes on the intersecting streets are expected to increase. It is possible that decreased traffic volumes on 99W may lead to larger and more frequent gaps in traffic and improved flow, improving safety conditions and reducing the likelihood of rear-end collisions. Increased demand on the intersecting side streets may negate this effect.

One intersection not on 99W, Alder Street/9<sup>th</sup> Street, was identified as a high collision location with potential geometric and sight distance issues. Traffic volumes at this intersection are expected to increase by 2035, increasing vehicle exposure to these safety issues.

## Walking Needs

Dundee is compact and walkable. Its center (measured from about 7<sup>th</sup> Street/Highway 99W) is around a half mile or less from just about any location in the city, and the streets generally form a well-connected, low-traffic grid. The 99W 1<sup>st</sup> Street to Parks Drive Streetscape Project is expected to provide a more comfortable pedestrian environment in downtown Dundee. The streetscape project is likely to encourage more pedestrian activity along Highway 99W and connecting streets. By 2035, pedestrian activity is likely to increase significantly as population and employment grows, and non-local traffic is diverted to the Bypass. This means that correcting deficiencies in the pedestrian network becomes even more important.



**Crosswalk at 10<sup>th</sup> Street is signed but not signaled**

- With more pedestrians in downtown Dundee, there will be more demand for comfortable crossings on 99W. Existing crosswalks at 7<sup>th</sup>, 8<sup>th</sup>, and 10<sup>th</sup> do not have signals or other treatments to increase visibility, and field observations showed that motor vehicles do not often yield to pedestrians. Providing a high quality crossing near the pair of bus stops on either side of Highway 99W near 10<sup>th</sup> Street will be especially important.
- No marked pedestrian crossings of Highway 99W are currently provided north of 5<sup>th</sup> Street.
- The local pedestrian network should have clear connections with the future Chehalem Heritage Trail being planned by the Chehalem Park and Recreation District (CPRD).<sup>5</sup> This trail system will likely have key facilities north along Dayton Avenue and west along NE Worden Hill Road (NE 9<sup>th</sup> Street) and NE Red Hills Road.

### **Highway 99W: Calmer After the Bypass**

Note that pedestrian crossing conditions and the pedestrian environment in general along Highway 99W will feel safer and more comfortable after the Newberg-Dundee Bypass is complete, particularly south of 5<sup>th</sup> Street. This improved environment is a key benefit of the Bypass investment. When leveraged with improvements like the current 1<sup>st</sup> Street to Parks Drive project, the City will likely see improved livability and stronger tourism.

<sup>5</sup> See the *Chehalem Heritage Trail Strategic Plan*, Chehalem Park and Recreation District, 2010.



## Biking Needs

As both population and employment increase in the Dundee area, more Dundee residents are expected to live closer to work. This may spur an increase in the number of commuters biking and walking to work.

Existing conditions analysis showed that around one in four Dundee residents who commute to another city for work are headed to Newberg. This is about a 2-to-4 mile one-way trip (depending on original and destination) – a distance that is ideal for bicycle commuting. A potential regional trail system connecting Newberg and Dundee (as well as other areas of Yamhill County) would make bicycling between the cities more comfortable and accessible, and may increase the number of bike commuters and recreational riders between the cities.

This means that Dundee has excellent potential to increase the number of people who travel by bike. It also highlights the importance of identifying and improving key bike connections into and out of the city.

- Highway 99W is the only street in Dundee with striped bike lanes. The bike lanes are relatively narrow (4-5 feet) and are often covered with gravel or other debris. As the number of cyclists increases, services such as better street sweeping to clear the bike lanes will become more important.
- A shared-use path connection are between Dundee and Newberg (such as on the Edwards Drive-Dayton Avenue alignment) would provide a more comfortable, lower-stress bicycle environment, reducing demand on Highway 99W.
- Dundee’s local street system (away from Highway 99W) generally features low volumes of motor vehicle traffic, and is suitable for shared use by cyclists, but is not marked or signed as such. Designated bike routes can provide continuity to other bicycle facilities such as roads with bike lanes and shared use paths. Including wayfinding signs will direct cyclists to key destinations such as shopping, employment centers, and schools. Wayfinding signs can also provide directions and distances to key connections to the bike network such as the trail connecting Newberg and Dundee.
- Parking is another important aspect of supporting increased biking. If safe and secure bike parking is not available, potential cyclists will be less likely to ride even if the trip is short and roadway facilities are comfortable. Bike parking should be considered at key destinations such as the commercial area on 99W in downtown Dundee, and in the future Riverside area. It is also important for businesses to provide long term bike parking for their employees.



**Cyclist on 99W avoiding debris in bike lane**



## Transit Needs

Transit service is currently provided in Dundee by Yamhill County Transit Area (YCTA), which provides two fixed bus routes connecting Dundee to destinations along the 99W corridor, including McMinnville, Newberg, Sherwood, and Tigard. YCTA also provides Americans with Disabilities Act (ADA) dial-a-ride service. The following are future considerations as Dundee grows:

- Route 44, a commuter service with limited stops along Highway 99W between McMinnville and Tigard, stops only on 9<sup>th</sup> Street (northbound) and 10<sup>th</sup> Street (southbound). As streetscape improvements and crossing locations on Highway 99W are contemplated, the location of these stops and proximity to comfortable pedestrian crossings should be considered in coordination with YCTA.
- Bus stops should be clearly identifiable, with amenities such as shelters and information where appropriate. Prominent stops help increase local awareness of transit options, and can enhance the street environment.
- Route 4 connects Newberg and Dundee, currently providing service at the 9<sup>th</sup> Street/10<sup>th</sup> Street stops on Highway 99W, and also service to two stops on the northern side of the City, along 5<sup>th</sup> Street on either side of the highway. Expansion of the transit network, and potentially this route in particular, should be considered for new urban growth areas. Connections to transit will be vitally important in Riverside where both households and employment are expected to grow significantly.
- Both routes provide infrequent service with one to two-hour headways between 6:00 a.m. and 7:00 p.m. Monday through Friday. Route 44 also makes four trips between 8:00 a.m. and 7:00 p.m. Saturday.



**Southbound bus stop at 99W/10<sup>th</sup> is not clearly marked**

## Freight Needs

ODOT classifies Highway 99W as a freight route through the City of Dundee. Currently, truck freight movements in Dundee involve shipments both to and from locations in the City, and shipments that pass through the City, mainly on 99W. With the construction of the Newberg-Dundee bypass, most of the through truck trips will likely be diverted onto the bypass rather than using 99W. However, the Riverside area is expected to attract commercial and industrial development, so local truck traffic may increase in Dundee over the planning horizon.

Development in the Riverside area should be designed to accommodate significant freight traffic. Turning radii and pavement design will be important along any future freight routes. Access points into the Riverside area should be evaluated for their appropriateness for freight, particularly turning movements, and designed and/or upgraded to accommodate truck traffic.

## **Transportation System Management and Operations Needs**

### ***Access Management***

An access inventory was conducted along Highway 99W as part of the existing conditions evaluation. All segments of 99W have more driveway and public street approaches than allowed under the applicable ODOT spacing standard. The stretch from 7<sup>th</sup> Street to Niederberger Road is particularly dense with driveways. As properties along 99W are redeveloped and streetscape improvements are designed, accesses should be removed or consolidated in order to move toward the standard. The City's current Transportation Enhancements project along Highway 99W is a good example of this kind of opportunity, and the City is addressing driveway consolidation as part of this project.

### ***Demand Management***

Currently, 80% of Dundee's residents commute to work in single occupancy vehicles despite the various travel options available. One option for encouraging other travel options, such as bicycling or transit, is to market the amenities available to commuters heading to Newberg, McMinnville, or the Portland Metro Area. In particular, the three-mile distance between central Newberg and central Dundee means that commuting or running errands between these cities by bicycle or on foot can be a great option. Wayfinding signage and pavement markings along future routes, including times and distances to key destinations can help promote nonmotorized travel. As new employers open for business in the Riverside area, there may be opportunities to market transit, walking, and biking as travel options to and from the area.

### **Air, Rail, Pipeline and Water Needs**

No system needs have been identified for Dundee's waterway or pipeline system through 2035. No air infrastructure exists in Dundee, and the City anticipates no pipeline or water needs for the foreseeable future. The Chehalem Paddle Launch is a key recreational destination in the Riverside area, and multimodal connections to this location should be considered as the area develops.

The Willamette & Pacific Railroad (WPRR) operates a rail line that runs parallel to 99W through Dundee. The line is currently used for freight movement, and has one train operating daily in each direction with up to two smaller trains operating periodically. There are no passenger rail services on this line currently, but the integrity of existing rights-of-way should be preserved in order to retain and enhance passenger and freight transportation options in the future.

---

## Appendix

### Highway Capacity Manual Analysis Worksheets (Synchro 8)

- 2035 30th Highest Hour
- 2035 Average Weekday

# HCM Unsignalized Intersection Capacity Analysis

## 1: 99W & NE Fox Farm Rd

10/1/2013



Movement	EBL	EBT	EBR	WBL	WBT	WBR	NBL	NBT	NBR	SBL	SBT	SBR
Lane Configurations		↕			↕		↕	↕			↕	↕
Volume (veh/h)	10	5	195	105	5	0	30	1025	60	2	890	10
Sign Control		Stop			Stop			Free			Free	
Grade		0%			0%			0%			0%	
Peak Hour Factor	0.96	0.96	0.96	0.96	0.96	0.96	0.96	0.96	0.96	0.96	0.96	0.96
Hourly flow rate (vph)	10	5	203	109	5	0	31	1068	62	2	927	10
Pedestrians												
Lane Width (ft)												
Walking Speed (ft/s)												
Percent Blockage												
Right turn flare (veh)												
Median type							TWLTL				None	
Median storage veh							2					
Upstream signal (ft)												
pX, platoon unblocked												
vC, conflicting volume	2064	2124	927	2298	2103	1099	938			1130		
vC1, stage 1 conf vol	931	931		1161	1161							
vC2, stage 2 conf vol	1133	1193		1137	942							
vCu, unblocked vol	2064	2124	927	2298	2103	1099	938			1130		
tC, single (s)	7.1	6.5	6.2	7.1	6.5	6.7	4.1			4.1		
tC, 2 stage (s)	6.1	5.5		6.1	5.5							
tF (s)	3.5	4.0	3.3	3.5	4.0	3.8	2.2			2.2		
p0 queue free %	94	97	38	0	97	100	96			100		
cM capacity (veh/h)	185	201	327	57	200	209	719			626		

Direction, Lane #	EB 1	WB 1	NB 1	NB 2	SB 1	SB 2
Volume Total	219	115	31	1130	929	10
Volume Left	10	109	31	0	2	0
Volume Right	203	0	0	62	0	10
cSH	311	59	719	1700	626	1700
Volume to Capacity	0.70	1.95	0.04	0.66	0.00	0.01
Queue Length 95th (ft)	124	273	3	0	0	0
Control Delay (s)	40.0	596.9	10.2	0.0	0.1	0.0
Lane LOS	E	F	B		A	
Approach Delay (s)	40.0	596.9	0.3		0.1	
Approach LOS	E	F				



















### Intersection Summary

Average Delay	31.9
Intersection Capacity Utilization	93.1%
ICU Level of Service	F
Analysis Period (min)	15

# HCM Unsignalized Intersection Capacity Analysis

## 2: 99W & SW 1st St/Driveway

10/1/2013

												
Movement	EBL	EBT	EBR	WBL	WBT	WBR	NBL	NBT	NBR	SBL	SBT	SBR
Lane Configurations												
Volume (veh/h)	50	0	25	10	0	55	15	1015	10	30	1065	95
Sign Control		Stop			Stop			Free			Free	
Grade		0%			0%			0%			0%	
Peak Hour Factor	0.97	0.97	0.97	0.97	0.97	0.97	0.97	0.97	0.97	0.97	0.97	0.97
Hourly flow rate (vph)	52	0	26	10	0	57	15	1046	10	31	1098	98
Pedestrians					2							
Lane Width (ft)					12.0							
Walking Speed (ft/s)					4.0							
Percent Blockage					0							
Right turn flare (veh)												
Median type								TWLTL			TWLTL	
Median storage (veh)								2			2	
Upstream signal (ft)												
pX, platoon unblocked												
vC, conflicting volume	2294	2249	1098	2270	2342	1054	1196			1059		
vC1, stage 1 conf vol	1160	1160		1084	1084							
vC2, stage 2 conf vol	1134	1090		1186	1258							
vCu, unblocked vol	2294	2249	1098	2270	2342	1054	1196			1059		
tC, single (s)	7.1	6.5	6.2	7.1	6.5	6.2	4.1			4.1		
tC, 2 stage (s)	6.1	5.5		6.1	5.5							
tF (s)	3.5	4.0	3.3	3.5	4.0	3.3	2.2			2.2		
p0 queue free %	60	100	90	93	100	79	97			95		
cM capacity (veh/h)	128	180	261	146	171	271	591			664		
<b>Direction, Lane #</b>	<b>EB 1</b>	<b>WB 1</b>	<b>NB 1</b>	<b>NB 2</b>	<b>SB 1</b>	<b>SB 2</b>	<b>SB 3</b>					
Volume Total	77	67	15	1057	31	1098	98					
Volume Left	52	10	15	0	31	0	0					
Volume Right	26	57	0	10	0	0	98					
cSH	154	239	591	1700	664	1700	1700					
Volume to Capacity	0.50	0.28	0.03	0.62	0.05	0.65	0.06					
Queue Length 95th (ft)	60	28	2	0	4	0	0					
Control Delay (s)	49.9	25.8	11.3	0.0	10.7	0.0	0.0					
Lane LOS	E	D	B		B							
Approach Delay (s)	49.9	25.8	0.2		0.3							
Approach LOS	E	D										
<b>Intersection Summary</b>												
Average Delay			2.5									
Intersection Capacity Utilization			78.9%		ICU Level of Service					D		
Analysis Period (min)			15									

# HCM Signalized Intersection Capacity Analysis

## 3: 99W & SW 5th St

10/1/2013



Movement	EBL	EBT	EBR	WBL	WBT	WBR	NBL	NBT	NBR	SBL	SBT	SBR
Lane Configurations												
Volume (vph)	65	25	10	75	25	255	5	710	20	230	820	25
Ideal Flow (vphpl)	1750	1750	1750	1750	1750	1750	1750	1750	1750	1750	1750	1750
Total Lost time (s)	4.0	4.0			4.0		4.0	4.0		4.0	4.0	
Lane Util. Factor	1.00	1.00			1.00		1.00	1.00		1.00	1.00	
Frbp, ped/bikes	1.00	0.99			0.98		1.00	1.00		1.00	1.00	
Flpb, ped/bikes	1.00	1.00			1.00		1.00	1.00		1.00	1.00	
Frt	1.00	0.96			0.90		1.00	1.00		1.00	1.00	
Flt Protected	0.95	1.00			0.99		0.95	1.00		0.95	1.00	
Satd. Flow (prot)	1599	1665			1495		1662	1694		1599	1708	
Flt Permitted	0.30	1.00			0.92		0.24	1.00		0.95	1.00	
Satd. Flow (perm)	497	1665			1391		416	1694		1599	1708	
Peak-hour factor, PHF	0.98	0.98	0.98	0.98	0.98	0.98	0.98	0.98	0.98	0.98	0.98	0.98
Adj. Flow (vph)	66	26	10	77	26	260	5	724	20	235	837	26
RTOR Reduction (vph)	0	7	0	0	57	0	0	1	0	0	1	0
Lane Group Flow (vph)	66	29	0	0	306	0	5	743	0	235	862	0
Confl. Peds. (#/hr)	4		2	2		4	2					2
Heavy Vehicles (%)	4%	0%	0%	0%	0%	3%	0%	3%	0%	4%	2%	0%
Turn Type	pm+pt	NA		Perm	NA		pm+pt	NA		custom	NA	
Protected Phases	3	8			4		1	6		5	2	
Permitted Phases	8			4			6			5		
Actuated Green, G (s)	42.4	42.4			35.5		75.0	74.3		24.7	98.3	
Effective Green, g (s)	42.4	42.4			35.5		75.0	74.3		24.7	98.3	
Actuated g/C Ratio	0.28	0.28			0.23		0.49	0.48		0.16	0.64	
Clearance Time (s)	4.0	4.0			4.0		4.0	4.0		4.0	4.0	
Vehicle Extension (s)	2.5	2.5			2.5		2.5	5.0		2.5	5.0	
Lane Grp Cap (vph)	158	460			321		209	820		257	1094	
v/s Ratio Prot	c0.01	0.02					0.00	c0.44		c0.15	0.50	
v/s Ratio Perm	0.11				c0.22		0.01					
v/c Ratio	0.42	0.06			0.95		0.02	0.91		0.91	0.79	
Uniform Delay, d1	53.7	40.9			58.1		21.8	36.4		63.3	20.0	
Progression Factor	1.00	1.00			1.00		1.00	1.00		1.00	1.00	
Incremental Delay, d2	1.3	0.0			37.8		0.0	14.3		34.0	4.4	
Delay (s)	55.0	40.9			95.9		21.8	50.7		97.3	24.4	
Level of Service	E	D			F		C	D		F	C	
Approach Delay (s)		50.0			95.9			50.5			40.0	
Approach LOS		D			F			D			D	

### Intersection Summary

HCM 2000 Control Delay	52.6	HCM 2000 Level of Service	D
HCM 2000 Volume to Capacity ratio	0.91		
Actuated Cycle Length (s)	153.4	Sum of lost time (s)	16.0
Intersection Capacity Utilization	95.7%	ICU Level of Service	F
Analysis Period (min)	15		
c Critical Lane Group			

# HCM Unsignalized Intersection Capacity Analysis

## 4: 99W & SW 7th St

10/1/2013



Movement	EBL	EBR	NBL	NBT	SBT	SBR
Lane Configurations						
Volume (veh/h)	55	50	20	670	865	30
Sign Control	Stop			Free	Free	
Grade	0%			0%	0%	
Peak Hour Factor	0.95	0.95	0.95	0.95	0.95	0.95
Hourly flow rate (vph)	58	53	21	705	911	32
Pedestrians						
Lane Width (ft)						
Walking Speed (ft/s)						
Percent Blockage						
Right turn flare (veh)						
Median type				TWLTL	TWLTL	
Median storage (veh)				2	2	
Upstream signal (ft)					717	
pX, platoon unblocked	0.61	0.61	0.61			
vC, conflicting volume	1674	926	942			
vC1, stage 1 conf vol	926					
vC2, stage 2 conf vol	747					
vCu, unblocked vol	1784	564	589			
tC, single (s)	6.4	6.2	4.1			
tC, 2 stage (s)	5.4					
tF (s)	3.5	3.3	2.2			
p0 queue free %	79	84	97			
cM capacity (veh/h)	271	322	604			

Direction, Lane #	EB 1	NB 1	NB 2	SB 1
Volume Total	111	21	705	942
Volume Left	58	21	0	0
Volume Right	53	0	0	32
cSH	293	604	1700	1700
Volume to Capacity	0.38	0.03	0.41	0.55
Queue Length 95th (ft)	42	3	0	0
Control Delay (s)	24.5	11.2	0.0	0.0
Lane LOS	C	B		
Approach Delay (s)	24.5	0.3		0.0
Approach LOS	C			



















Intersection Summary			
Average Delay		1.7	
Intersection Capacity Utilization	64.7%		ICU Level of Service C
Analysis Period (min)	15		



# HCM Unsignalized Intersection Capacity Analysis

5: 99W & SW 9th St

10/1/2013

												
Movement	EBL	EBT	EBR	WBL	WBT	WBR	NBL	NBT	NBR	SBL	SBT	SBR
Lane Configurations												
Volume (veh/h)	65	0	35	0	0	0	70	605	0	2	740	155
Sign Control		Stop			Stop			Free			Free	
Grade		0%			0%			0%			0%	
Peak Hour Factor	0.95	0.95	0.95	0.95	0.95	0.95	0.95	0.95	0.95	0.95	0.95	0.95
Hourly flow rate (vph)	68	0	37	0	0	0	74	637	0	2	779	163
Pedestrians												
Lane Width (ft)												
Walking Speed (ft/s)												
Percent Blockage												
Right turn flare (veh)												
Median type							TWTL			TWTL		
Median storage (veh)							2			2		
Upstream signal (ft)												
pX, platoon unblocked												
vC, conflicting volume	1649	1649	861	1604	1731	637	942			637		
vC1, stage 1 conf vol	865	865		784	784							
vC2, stage 2 conf vol	784	784		820	946							
vCu, unblocked vol	1649	1649	861	1604	1731	637	942			637		
tC, single (s)	7.1	6.5	6.2	7.1	6.5	6.2	4.1			4.1		
tC, 2 stage (s)	6.1	5.5		6.1	5.5							
tF (s)	3.5	4.0	3.3	3.5	4.0	3.3	2.2			2.2		
p0 queue free %	73	100	90	100	100	100	90			100		
cM capacity (veh/h)	249	267	355	212	222	477	728			947		
<b>Direction, Lane #</b>	<b>EB 1</b>	<b>WB 1</b>	<b>NB 1</b>	<b>NB 2</b>	<b>SB 1</b>	<b>SB 2</b>						
Volume Total	105	0	74	637	2	942						
Volume Left	68	0	74	0	2	0						
Volume Right	37	0	0	0	0	163						
cSH	278	1700	728	1700	947	1700						
Volume to Capacity	0.38	0.00	0.10	0.37	0.00	0.55						
Queue Length 95th (ft)	42	0	8	0	0	0						
Control Delay (s)	25.6	0.0	10.5	0.0	8.8	0.0						
Lane LOS	D	A	B		A							
Approach Delay (s)	25.6	0.0	1.1		0.0							
Approach LOS	D	A										
<b>Intersection Summary</b>												
Average Delay			2.0									
Intersection Capacity Utilization			73.0%		ICU Level of Service					C		
Analysis Period (min)			15									

HCM Unsignalized Intersection Capacity Analysis  
6: 99W & SW 10th St/SE 10th St

10/1/2013



Movement	EBL	EBT	EBR	WBL	WBT	WBR	NBL	NBT	NBR	SBL	SBT	SBR
Lane Configurations		↕			↕		↗	↘		↗	↘	
Volume (veh/h)	2	0	2	25	0	40	2	635	35	120	655	0
Sign Control		Stop			Stop			Free			Free	
Grade		0%			0%			0%			0%	
Peak Hour Factor	0.95	0.95	0.95	0.95	0.95	0.95	0.95	0.95	0.95	0.95	0.95	0.95
Hourly flow rate (vph)	2	0	2	26	0	42	2	668	37	126	689	0
Pedestrians		6			2							10
Lane Width (ft)		12.0			12.0							12.0
Walking Speed (ft/s)		4.0			4.0							4.0
Percent Blockage		1			0							1
Right turn flare (veh)												
Median type								TWLTL			TWLTL	
Median storage (veh)								2			2	
Upstream signal (ft)												
pX, platoon unblocked												
vC, conflicting volume	1673	1660	695	1637	1641	699	695			707		
vC1, stage 1 conf vol	948	948		693	693							
vC2, stage 2 conf vol	725	711		944	948							
vCu, unblocked vol	1673	1660	695	1637	1641	699	695			707		
tC, single (s)	7.6	6.5	6.2	7.1	6.5	6.4	4.1			4.2		
tC, 2 stage (s)	6.6	5.5		6.1	5.5							
tF (s)	4.0	4.0	3.3	3.5	4.0	3.5	2.2			2.3		
p0 queue free %	99	100	100	89	100	90	100			86		
cM capacity (veh/h)	145	223	443	231	248	411	905			872		

Direction, Lane #	EB 1	WB 1	NB 1	NB 2	SB 1	SB 2
Volume Total	4	68	2	705	126	689
Volume Left	2	26	2	0	126	0
Volume Right	2	42	0	37	0	0
cSH	218	316	905	1700	872	1700
Volume to Capacity	0.02	0.22	0.00	0.41	0.14	0.41
Queue Length 95th (ft)	1	20	0	0	13	0
Control Delay (s)	21.8	19.5	9.0	0.0	9.8	0.0
Lane LOS	C	C	A		A	
Approach Delay (s)	21.8	19.5	0.0		1.5	
Approach LOS	C	C				

Intersection Summary		
Average Delay		1.7
Intersection Capacity Utilization	63.5%	ICU Level of Service
Analysis Period (min)	15	B

# HCM Unsignalized Intersection Capacity Analysis

## 7: 99W & SW Niederberger Dr/SE Parks Dr

10/1/2013



Movement	EBL	EBT	EBR	WBL	WBT	WBR	NBL	NBT	NBR	SBL	SBT	SBR
Lane Configurations		↔			↔		↗	↘		↗	↘	
Volume (veh/h)	20	0	15	15	20	45	10	565	80	155	470	20
Sign Control		Stop			Stop			Free			Free	
Grade		0%			0%			0%			0%	
Peak Hour Factor	0.95	0.95	0.95	0.95	0.95	0.95	0.95	0.95	0.95	0.95	0.95	0.95
Hourly flow rate (vph)	21	0	16	16	21	47	11	595	84	163	495	21
Pedestrians												
Lane Width (ft)												
Walking Speed (ft/s)												
Percent Blockage												
Right turn flare (veh)												
Median type								None			TWLTL	
Median storage (veh)												2
Upstream signal (ft)												
pX, platoon unblocked												
vC, conflicting volume	1505	1532	505	1495	1500	637	516			679		
vC1, stage 1 conf vol	832	832		658	658							
vC2, stage 2 conf vol	674	700		837	842							
vCu, unblocked vol	1505	1532	505	1495	1500	637	516			679		
tC, single (s)	7.2	6.5	6.2	7.1	6.5	6.7	4.1			4.1		
tC, 2 stage (s)	6.2	5.5		6.1	5.5							
tF (s)	3.6	4.0	3.3	3.5	4.0	3.8	2.2			2.2		
p0 queue free %	88	100	97	94	92	88	99			82		
cM capacity (veh/h)	169	223	571	244	263	401	1060			923		

Direction, Lane #	EB 1	WB 1	NB 1	NB 2	SB 1	SB 2
Volume Total	37	84	11	679	163	516
Volume Left	21	16	11	0	163	0
Volume Right	16	47	0	84	0	21
cSH	242	321	1060	1700	923	1700
Volume to Capacity	0.15	0.26	0.01	0.40	0.18	0.30
Queue Length 95th (ft)	13	26	1	0	16	0
Control Delay (s)	22.5	20.2	8.4	0.0	9.7	0.0
Lane LOS	C	C	A		A	
Approach Delay (s)	22.5	20.2	0.1		2.3	
Approach LOS	C	C				

### Intersection Summary

Average Delay	2.8
Intersection Capacity Utilization	62.3%
ICU Level of Service	B
Analysis Period (min)	15

# HCM Unsignalized Intersection Capacity Analysis

## 8: SW Alder St & SW Upland Dr

10/1/2013



Movement	EBL	EBT	EBR	WBL	WBT	WBR	NBL	NBT	NBR	SBL	SBT	SBR
Lane Configurations		↕			↕			↕			↕	
Sign Control		Stop			Stop			Stop			Stop	
Volume (vph)	5	10	5	5	15	15	10	10	15	5	5	5
Peak Hour Factor	0.88	0.88	0.88	0.88	0.88	0.88	0.88	0.88	0.88	0.88	0.88	0.88
Hourly flow rate (vph)	6	11	6	6	17	17	11	11	17	6	6	6

Direction, Lane #	EB 1	WB 1	NB 1	SB 1
Volume Total (vph)	23	40	40	17
Volume Left (vph)	6	6	11	6
Volume Right (vph)	6	17	17	6
Hadj (s)	-0.07	-0.19	-0.17	-0.10
Departure Headway (s)	4.0	3.8	3.9	4.0
Degree Utilization, x	0.03	0.04	0.04	0.02
Capacity (veh/h)	882	917	901	887
Control Delay (s)	7.1	7.0	7.1	7.0
Approach Delay (s)	7.1	7.0	7.1	7.0
Approach LOS	A	A	A	A

Intersection Summary			
Delay		7.0	
Level of Service		A	
Intersection Capacity Utilization	13.3%		ICU Level of Service A
Analysis Period (min)		15	

# HCM Unsignalized Intersection Capacity Analysis

## 9: SW Alder St & SW 9th St

10/1/2013



Movement	EBL	EBT	EBR	WBL	WBT	WBR	NBL	NBT	NBR	SBL	SBT	SBR
Lane Configurations		↕			↕			↕			↕	
Volume (veh/h)	2	85	2	10	145	5	2	35	5	5	2	2
Sign Control		Free			Free			Stop			Stop	
Grade		0%			0%			0%			0%	
Peak Hour Factor	0.85	0.85	0.85	0.85	0.85	0.85	0.85	0.85	0.85	0.85	0.85	0.85
Hourly flow rate (vph)	2	100	2	12	171	6	2	41	6	6	2	2
Pedestrians												
Lane Width (ft)												
Walking Speed (ft/s)												
Percent Blockage												
Right turn flare (veh)												
Median type		None			None							
Median storage (veh)												
Upstream signal (ft)												
pX, platoon unblocked												
vC, conflicting volume	176			102			306	306	101	329	304	174
vC1, stage 1 conf vol												
vC2, stage 2 conf vol												
vCu, unblocked vol	176			102			306	306	101	329	304	174
tC, single (s)	4.1			4.1			7.1	6.5	6.2	7.1	6.5	6.2
tC, 2 stage (s)												
tF (s)	2.2			2.2			3.5	4.0	3.3	3.5	4.0	3.3
p0 queue free %	100			99			100	93	99	99	100	100
cM capacity (veh/h)	1400			1490			638	602	954	583	603	870

Direction, Lane #	EB 1	WB 1	NB 1	SB 1
Volume Total	105	188	49	11
Volume Left	2	12	2	6
Volume Right	2	6	6	2
cSH	1400	1490	631	634
Volume to Capacity	0.00	0.01	0.08	0.02
Queue Length 95th (ft)	0	1	6	1
Control Delay (s)	0.2	0.5	11.2	10.8
Lane LOS	A	A	B	B
Approach Delay (s)	0.2	0.5	11.2	10.8
Approach LOS			B	B

### Intersection Summary

Average Delay	2.2
Intersection Capacity Utilization	24.1%
ICU Level of Service	A
Analysis Period (min)	15

# HCM Unsignalized Intersection Capacity Analysis

## 10: SE Edwards Dr & SW 5th St

10/1/2013



Movement	EBL	EBR	NBL	NBT	SBT	SBR
Lane Configurations						
Volume (veh/h)	5	250	325	5	0	10
Sign Control	Stop			Free	Free	
Grade	0%			0%	0%	
Peak Hour Factor	0.90	0.90	0.90	0.90	0.90	0.90
Hourly flow rate (vph)	6	278	361	6	0	11
Pedestrians						
Lane Width (ft)						
Walking Speed (ft/s)						
Percent Blockage						
Right turn flare (veh)						
Median type				None	None	
Median storage (veh)						
Upstream signal (ft)						
pX, platoon unblocked						
vC, conflicting volume	733	6	11			
vC1, stage 1 conf vol						
vC2, stage 2 conf vol						
vCu, unblocked vol	733	6	11			
tC, single (s)	6.4	6.2	4.1			
tC, 2 stage (s)						
tF (s)	3.5	3.3	2.2			
p0 queue free %	98	74	78			
cM capacity (veh/h)	301	1077	1608			
Direction, Lane #	EB 1	NB 1	SB 1			
Volume Total	283	367	11			
Volume Left	6	361	0			
Volume Right	278	0	11			
cSH	1025	1608	1700			
Volume to Capacity	0.28	0.22	0.01			
Queue Length 95th (ft)	28	22	0			
Control Delay (s)	9.8	7.8	0.0			
Lane LOS	A	A				
Approach Delay (s)	9.8	7.8	0.0			
Approach LOS	A					
Intersection Summary						
Average Delay			8.5			
Intersection Capacity Utilization			50.3%	ICU Level of Service	A	
Analysis Period (min)			15			

HCM Unsignalized Intersection Capacity Analysis  
 12: SW 5th St & SW Upland Dr

10/1/2013

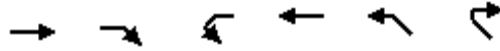









Movement	EBT	EBR	WBL	WBT	NWL	NWR
Lane Configurations	➔			➔	➔	
Sign Control	Stop			Stop	Stop	
Volume (vph)	0	70	0	0	45	0
Peak Hour Factor	0.98	0.98	0.98	0.98	0.98	0.98
Hourly flow rate (vph)	0	71	0	0	46	0
Direction, Lane #	EB 1	WB 1	NW 1			
Volume Total (vph)	71	0	46			
Volume Left (vph)	0	0	46			
Volume Right (vph)	71	0	0			
Hadj (s)	-0.57	0.00	0.23			
Departure Headway (s)	3.4	4.1	4.3			
Degree Utilization, x	0.07	0.00	0.05			
Capacity (veh/h)	1027	879	820			
Control Delay (s)	6.7	7.1	7.5			
Approach Delay (s)	6.7	0.0	7.5			
Approach LOS	A	A	A			
Intersection Summary						
Delay			7.0			
Level of Service			A			
Intersection Capacity Utilization			14.7%	ICU Level of Service	A	
Analysis Period (min)			15			



# HCM Unsignalized Intersection Capacity Analysis

## 29: SE Parks Dr & SE Edwards Dr

10/1/2013

						
Movement	NBL	NBR	SEL	SER	SWL	SWR
Lane Configurations						
Volume (veh/h)	75	5	25	200	10	5
Sign Control	Free		Free		Stop	
Grade	0%		0%		0%	
Peak Hour Factor	0.98	0.98	0.98	0.98	0.98	0.98
Hourly flow rate (vph)	77	5	26	204	10	5
Pedestrians						
Lane Width (ft)						
Walking Speed (ft/s)						
Percent Blockage						
Right turn flare (veh)						
Median type	None		None			
Median storage (veh)						
Upstream signal (ft)						
pX, platoon unblocked						
vC, conflicting volume			82		334	79
vC1, stage 1 conf vol						
vC2, stage 2 conf vol						
vCu, unblocked vol			82		334	79
tC, single (s)			4.1		6.4	6.2
tC, 2 stage (s)						
tF (s)			2.2		3.5	3.3
p0 queue free %			98		98	99
cM capacity (veh/h)			1516		650	981
<b>Direction, Lane #</b>	<b>NB 1</b>	<b>SE 1</b>	<b>SW 1</b>			
Volume Total	82	230	15			
Volume Left	0	26	10			
Volume Right	5	0	5			
cSH	1700	1516	732			
Volume to Capacity	0.05	0.02	0.02			
Queue Length 95th (ft)	0	1	2			
Control Delay (s)	0.0	1.0	10.0			
Lane LOS		A	B			
Approach Delay (s)	0.0	1.0	10.0			
Approach LOS			B			
<b>Intersection Summary</b>						
Average Delay			1.1			
Intersection Capacity Utilization			33.1%	ICU Level of Service		A
Analysis Period (min)			15			

# HCM Unsignalized Intersection Capacity Analysis

## 1: 99W & NE Fox Farm Rd

10/1/2013



Movement	EBL	EBT	EBR	WBL	WBT	WBR	NBL	NBT	NBR	SBL	SBT	SBR
Lane Configurations		↕			↕		↕	↕			↕	↕
Volume (veh/h)	10	5	180	95	5	0	30	975	60	2	835	10
Sign Control		Stop			Stop			Free			Free	
Grade		0%			0%			0%			0%	
Peak Hour Factor	0.96	0.96	0.96	0.96	0.96	0.96	0.96	0.96	0.96	0.96	0.96	0.96
Hourly flow rate (vph)	10	5	188	99	5	0	31	1016	62	2	870	10
Pedestrians												
Lane Width (ft)												
Walking Speed (ft/s)												
Percent Blockage												
Right turn flare (veh)												
Median type							TWLTL				None	
Median storage (veh)							2					
Upstream signal (ft)												
pX, platoon unblocked												
vC, conflicting volume	1955	2015	870	2173	1994	1047	880			1078		
vC1, stage 1 conf vol	874	874		1109	1109							
vC2, stage 2 conf vol	1081	1141		1064	884							
vCu, unblocked vol	1955	2015	870	2173	1994	1047	880			1078		
tC, single (s)	7.1	6.5	6.2	7.1	6.5	6.7	4.1			4.1		
tC, 2 stage (s)	6.1	5.5		6.1	5.5							
tF (s)	3.5	4.0	3.3	3.5	4.0	3.8	2.2			2.2		
p0 queue free %	95	98	47	0	98	100	96			100		
cM capacity (veh/h)	200	216	352	85	214	225	755			654		

Direction, Lane #	EB 1	WB 1	NB 1	NB 2	SB 1	SB 2
Volume Total	203	104	31	1078	872	10
Volume Left	10	99	31	0	2	0
Volume Right	188	0	0	62	0	10
cSH	334	88	755	1700	654	1700
Volume to Capacity	0.61	1.19	0.04	0.63	0.00	0.01
Queue Length 95th (ft)	95	184	3	0	0	0
Control Delay (s)	31.2	242.6	10.0	0.0	0.1	0.0
Lane LOS	D	F	A		A	
Approach Delay (s)	31.2	242.6	0.3		0.1	
Approach LOS	D	F				

### Intersection Summary

Average Delay	13.9
Intersection Capacity Utilization	88.6%
ICU Level of Service	E
Analysis Period (min)	15

# HCM Unsignalized Intersection Capacity Analysis

## 2: 99W & SW 1st St/Driveway

10/1/2013



Movement	EBL	EBT	EBR	WBL	WBT	WBR	NBL	NBT	NBR	SBL	SBT	SBR
Lane Configurations		↔			↔		↗	↑		↖	↑	↗
Volume (veh/h)	50	0	25	5	0	55	15	960	10	25	995	90
Sign Control		Stop			Stop			Free			Free	
Grade		0%			0%			0%			0%	
Peak Hour Factor	0.97	0.97	0.97	0.97	0.97	0.97	0.97	0.97	0.97	0.97	0.97	0.97
Hourly flow rate (vph)	52	0	26	5	0	57	15	990	10	26	1026	93
Pedestrians					2							
Lane Width (ft)					12.0							
Walking Speed (ft/s)					4.0							
Percent Blockage					0							
Right turn flare (veh)												
Median type							TWLTL			TWLTL		
Median storage veh							2			2		
Upstream signal (ft)												
pX, platoon unblocked												
vC, conflicting volume	2155	2110	1026	2131	2198	997	1119			1002		
vC1, stage 1 conf vol	1077	1077		1028	1028							
vC2, stage 2 conf vol	1077	1033		1103	1170							
vCu, unblocked vol	2155	2110	1026	2131	2198	997	1119			1002		
tC, single (s)	7.1	6.5	6.2	7.1	6.5	6.2	4.1			4.1		
tC, 2 stage (s)	6.1	5.5		6.1	5.5							
tF (s)	3.5	4.0	3.3	3.5	4.0	3.3	2.2			2.2		
p0 queue free %	65	100	91	97	100	81	98			96		
cM capacity (veh/h)	147	200	288	165	189	292	632			698		

Direction, Lane #	EB 1	WB 1	NB 1	NB 2	SB 1	SB 2	SB 3
Volume Total	77	62	15	1000	26	1026	93
Volume Left	52	5	15	0	26	0	0
Volume Right	26	57	0	10	0	0	93
cSH	175	274	632	1700	698	1700	1700
Volume to Capacity	0.44	0.23	0.02	0.59	0.04	0.60	0.05
Queue Length 95th (ft)	51	21	2	0	3	0	0
Control Delay (s)	40.8	21.9	10.8	0.0	10.4	0.0	0.0
Lane LOS	E	C	B		B		
Approach Delay (s)	40.8	21.9	0.2		0.2		
Approach LOS	E	C					

Intersection Summary			
Average Delay		2.2	
Intersection Capacity Utilization	74.9%		ICU Level of Service D
Analysis Period (min)		15	

# HCM Signalized Intersection Capacity Analysis

## 3: 99W & SW 5th St

10/1/2013



Movement	EBL	EBT	EBR	WBL	WBT	WBR	NBL	NBT	NBR	SBL	SBT	SBR
Lane Configurations												
Volume (vph)	65	30	10	75	25	250	5	650	20	220	760	25
Ideal Flow (vphpl)	1750	1750	1750	1750	1750	1750	1750	1750	1750	1750	1750	1750
Total Lost time (s)	4.0	4.0			4.0		4.0	4.0		4.0	4.0	
Lane Util. Factor	1.00	1.00			1.00		1.00	1.00		1.00	1.00	
Frbp, ped/bikes	1.00	0.99			0.98		1.00	1.00		1.00	1.00	
Flpb, ped/bikes	1.00	1.00			1.00		1.00	1.00		1.00	1.00	
Frt	1.00	0.96			0.90		1.00	1.00		1.00	1.00	
Flt Protected	0.95	1.00			0.99		0.95	1.00		0.95	1.00	
Satd. Flow (prot)	1599	1676			1497		1662	1693		1599	1707	
Flt Permitted	0.31	1.00			0.92		0.28	1.00		0.95	1.00	
Satd. Flow (perm)	522	1676			1391		482	1693		1599	1707	
Peak-hour factor, PHF	0.98	0.98	0.98	0.98	0.98	0.98	0.98	0.98	0.98	0.98	0.98	0.98
Adj. Flow (vph)	66	31	10	77	26	255	5	663	20	224	776	26
RTOR Reduction (vph)	0	7	0	0	56	0	0	1	0	0	1	0
Lane Group Flow (vph)	66	34	0	0	302	0	5	682	0	224	801	0
Confl. Peds. (#/hr)	4		2	2		4	2					2
Heavy Vehicles (%)	4%	0%	0%	0%	0%	3%	0%	3%	0%	4%	2%	0%
Turn Type	pm+pt	NA		Perm	NA		pm+pt	NA		custom	NA	
Protected Phases	3	8			4		1	6		5	2	
Permitted Phases	8			4			6			5		
Actuated Green, G (s)	41.4	41.4			34.6		67.8	67.2		23.8	90.4	
Effective Green, g (s)	41.4	41.4			34.6		67.8	67.2		23.8	90.4	
Actuated g/C Ratio	0.29	0.29			0.24		0.47	0.47		0.16	0.63	
Clearance Time (s)	4.0	4.0			4.0		4.0	4.0		4.0	4.0	
Vehicle Extension (s)	2.5	2.5			2.5		2.5	5.0		2.5	5.0	
Lane Grp Cap (vph)	170	480			333		231	787		263	1068	
v/s Ratio Prot	c0.01	0.02					0.00	c0.40		c0.14	0.47	
v/s Ratio Perm	0.10				c0.22		0.01					
v/c Ratio	0.39	0.07			0.91		0.02	0.87		0.85	0.75	
Uniform Delay, d1	48.8	37.5			53.3		21.3	34.6		58.6	19.0	
Progression Factor	1.00	1.00			1.00		1.00	1.00		1.00	1.00	
Incremental Delay, d2	1.1	0.0			26.8		0.0	10.8		22.1	3.6	
Delay (s)	49.9	37.5			80.1		21.3	45.4		80.7	22.6	
Level of Service	D	D			F		C	D		F	C	
Approach Delay (s)		45.1			80.1			45.2			35.3	
Approach LOS		D			F			D			D	

### Intersection Summary

HCM 2000 Control Delay	46.3	HCM 2000 Level of Service	D
HCM 2000 Volume to Capacity ratio	0.86		
Actuated Cycle Length (s)	144.4	Sum of lost time (s)	16.0
Intersection Capacity Utilization	91.3%	ICU Level of Service	F
Analysis Period (min)	15		
c Critical Lane Group			

# HCM Unsignalized Intersection Capacity Analysis

## 4: 99W & SW 7th St

10/1/2013



Movement	EBL	EBR	NBL	NBT	SBT	SBR
Lane Configurations						
Volume (veh/h)	55	50	20	610	805	30
Sign Control	Stop			Free	Free	
Grade	0%			0%	0%	
Peak Hour Factor	0.95	0.95	0.95	0.95	0.95	0.95
Hourly flow rate (vph)	58	53	21	642	847	32
Pedestrians						
Lane Width (ft)						
Walking Speed (ft/s)						
Percent Blockage						
Right turn flare (veh)						
Median type				TWLTL	TWLTL	
Median storage (veh)				2	2	
Upstream signal (ft)					717	
pX, platoon unblocked	0.66	0.66	0.66			
vC, conflicting volume	1547	863	879			
vC1, stage 1 conf vol	863					
vC2, stage 2 conf vol	684					
vCu, unblocked vol	1572	528	552			
tC, single (s)	6.4	6.2	4.1			
tC, 2 stage (s)	5.4					
tF (s)	3.5	3.3	2.2			
p0 queue free %	81	85	97			
cM capacity (veh/h)	303	361	667			



















Direction, Lane #	EB 1	NB 1	NB 2	SB 1
Volume Total	111	21	642	879
Volume Left	58	21	0	0
Volume Right	53	0	0	32
cSH	328	667	1700	1700
Volume to Capacity	0.34	0.03	0.38	0.52
Queue Length 95th (ft)	36	2	0	0
Control Delay (s)	21.4	10.6	0.0	0.0
Lane LOS	C	B		
Approach Delay (s)	21.4	0.3		0.0
Approach LOS	C			

Intersection Summary			
Average Delay		1.6	
Intersection Capacity Utilization	61.3%		ICU Level of Service B
Analysis Period (min)	15		

# HCM Unsignalized Intersection Capacity Analysis

## 5: 99W & SW 9th St

10/1/2013

												
Movement	EBL	EBT	EBR	WBL	WBT	WBR	NBL	NBT	NBR	SBL	SBT	SBR
Lane Configurations												
Volume (veh/h)	65	0	30	0	0	0	60	545	0	2	685	150
Sign Control		Stop			Stop			Free			Free	
Grade		0%			0%			0%			0%	
Peak Hour Factor	0.95	0.95	0.95	0.95	0.95	0.95	0.95	0.95	0.95	0.95	0.95	0.95
Hourly flow rate (vph)	68	0	32	0	0	0	63	574	0	2	721	158
Pedestrians												
Lane Width (ft)												
Walking Speed (ft/s)												
Percent Blockage												
Right turn flare (veh)												
Median type								TWLTL			TWLTL	
Median storage (veh)								2			2	
Upstream signal (ft)												
pX, platoon unblocked												
vC, conflicting volume	1504	1504	800	1457	1583	574	879			574		
vC1, stage 1 conf vol	804	804		700	700							
vC2, stage 2 conf vol	700	700		757	883							
vCu, unblocked vol	1504	1504	800	1457	1583	574	879			574		
tC, single (s)	7.1	6.5	6.2	7.1	6.5	6.2	4.1			4.1		
tC, 2 stage (s)	6.1	5.5		6.1	5.5							
tF (s)	3.5	4.0	3.3	3.5	4.0	3.3	2.2			2.2		
p0 queue free %	76	100	92	100	100	100	92			100		
cM capacity (veh/h)	280	296	385	250	252	518	769			999		
<b>Direction, Lane #</b>	<b>EB 1</b>	<b>WB 1</b>	<b>NB 1</b>	<b>NB 2</b>	<b>SB 1</b>	<b>SB 2</b>						
Volume Total	100	0	63	574	2	879						
Volume Left	68	0	63	0	2	0						
Volume Right	32	0	0	0	0	158						
cSH	306	1700	769	1700	999	1700						
Volume to Capacity	0.33	0.00	0.08	0.34	0.00	0.52						
Queue Length 95th (ft)	34	0	7	0	0	0						
Control Delay (s)	22.3	0.0	10.1	0.0	8.6	0.0						
Lane LOS	C	A	B		A							
Approach Delay (s)	22.3	0.0	1.0		0.0							
Approach LOS	C	A										
<b>Intersection Summary</b>												
Average Delay			1.8									
Intersection Capacity Utilization			66.7%		ICU Level of Service					C		
Analysis Period (min)			15									

# HCM Unsignalized Intersection Capacity Analysis

## 6: 99W & SW 10th St/SE 10th St

10/1/2013



Movement	EBL	EBT	EBR	WBL	WBT	WBR	NBL	NBT	NBR	SBL	SBT	SBR
Lane Configurations		↕			↕		↕	↕		↕	↕	
Volume (veh/h)	2	0	2	25	0	40	2	565	40	115	600	0
Sign Control		Stop			Stop			Free			Free	
Grade		0%			0%			0%			0%	
Peak Hour Factor	0.95	0.95	0.95	0.95	0.95	0.95	0.95	0.95	0.95	0.95	0.95	0.95
Hourly flow rate (vph)	2	0	2	26	0	42	2	595	42	121	632	0
Pedestrians		6			2							10
Lane Width (ft)		12.0			12.0						12.0	
Walking Speed (ft/s)		4.0			4.0						4.0	
Percent Blockage		1			0							1
Right turn flare (veh)												
Median type								TWLTL			TWLTL	
Median storage (veh)								2			2	
Upstream signal (ft)												
pX, platoon unblocked												
vC, conflicting volume	1531	1523	638	1498	1502	628	638			639		
vC1, stage 1 conf vol	880	880		622	622							
vC2, stage 2 conf vol	651	643		876	880							
vCu, unblocked vol	1531	1523	638	1498	1502	628	638			639		
tC, single (s)	7.6	6.5	6.2	7.1	6.5	6.4	4.1			4.2		
tC, 2 stage (s)	6.6	5.5		6.1	5.5							
tF (s)	4.0	4.0	3.3	3.5	4.0	3.5	2.2			2.3		
p0 queue free %	99	100	100	90	100	91	100			87		
cM capacity (veh/h)	172	250	478	259	274	452	951			925		

Direction, Lane #	EB 1	WB 1	NB 1	NB 2	SB 1	SB 2
Volume Total	4	68	2	637	121	632
Volume Left	2	26	2	0	121	0
Volume Right	2	42	0	42	0	0
cSH	253	351	951	1700	925	1700
Volume to Capacity	0.02	0.19	0.00	0.37	0.13	0.37
Queue Length 95th (ft)	1	18	0	0	11	0
Control Delay (s)	19.5	17.7	8.8	0.0	9.5	0.0
Lane LOS	C	C	A		A	
Approach Delay (s)	19.5	17.7	0.0		1.5	
Approach LOS	C	C				

### Intersection Summary

Average Delay		1.7				
Intersection Capacity Utilization		59.5%		ICU Level of Service		B
Analysis Period (min)		15				



# HCM Unsignalized Intersection Capacity Analysis

## 7: 99W & SW Niederberger Dr/SE Parks Dr

10/1/2013



Movement	EBL	EBT	EBR	WBL	WBT	WBR	NBL	NBT	NBR	SBL	SBT	SBR
Lane Configurations		↔			↔		↗	↘		↗	↘	
Volume (veh/h)	20	0	10	10	20	45	10	500	80	160	405	20
Sign Control		Stop			Stop			Free			Free	
Grade		0%			0%			0%			0%	
Peak Hour Factor	0.95	0.95	0.95	0.95	0.95	0.95	0.95	0.95	0.95	0.95	0.95	0.95
Hourly flow rate (vph)	21	0	11	11	21	47	11	526	84	168	426	21
Pedestrians												
Lane Width (ft)												
Walking Speed (ft/s)												
Percent Blockage												
Right turn flare (veh)												
Median type								None			TWLTL	
Median storage veh											2	
Upstream signal (ft)												
pX, platoon unblocked												
vC, conflicting volume	1379	1405	437	1363	1374	568	447			611		
vC1, stage 1 conf vol	774	774		589	589							
vC2, stage 2 conf vol	605	632		774	784							
vCu, unblocked vol	1379	1405	437	1363	1374	568	447			611		
tC, single (s)	7.2	6.5	6.2	7.1	6.5	6.7	4.1			4.1		
tC, 2 stage (s)	6.2	5.5		6.1	5.5							
tF (s)	3.6	4.0	3.3	3.5	4.0	3.8	2.2			2.2		
p0 queue free %	89	100	98	96	93	89	99			83		
cM capacity (veh/h)	196	246	624	273	286	442	1124			978		

Direction, Lane #	EB 1	WB 1	NB 1	NB 2	SB 1	SB 2
Volume Total	32	79	11	611	168	447
Volume Left	21	11	11	0	168	0
Volume Right	11	47	0	84	0	21
cSH	254	360	1124	1700	978	1700
Volume to Capacity	0.12	0.22	0.01	0.36	0.17	0.26
Queue Length 95th (ft)	10	21	1	0	16	0
Control Delay (s)	21.2	17.8	8.2	0.0	9.4	0.0
Lane LOS	C	C	A		A	
Approach Delay (s)	21.2	17.8	0.1		2.6	
Approach LOS	C	C				

### Intersection Summary

Average Delay	2.8
Intersection Capacity Utilization	60.0%
ICU Level of Service	B
Analysis Period (min)	15

# HCM Unsignalized Intersection Capacity Analysis

## 8: SW Alder St & SW Upland Dr

10/1/2013



Movement	EBL	EBT	EBR	WBL	WBT	WBR	NBL	NBT	NBR	SBL	SBT	SBR
Lane Configurations		↕			↕			↕			↕	
Sign Control		Stop			Stop			Stop			Stop	
Volume (vph)	5	5	5	5	10	15	5	10	15	5	5	5
Peak Hour Factor	0.88	0.88	0.88	0.88	0.88	0.88	0.88	0.88	0.88	0.88	0.88	0.88
Hourly flow rate (vph)	6	6	6	6	11	17	6	11	17	6	6	6

Direction, Lane #	EB 1	WB 1	NB 1	SB 1
Volume Total (vph)	17	34	34	17
Volume Left (vph)	6	6	6	6
Volume Right (vph)	6	17	17	6
Hadj (s)	-0.10	-0.23	-0.23	-0.10
Departure Headway (s)	3.9	3.8	3.8	3.9
Degree Utilization, x	0.02	0.04	0.04	0.02
Capacity (veh/h)	895	932	925	897
Control Delay (s)	7.0	6.9	6.9	7.0
Approach Delay (s)	7.0	6.9	6.9	7.0
Approach LOS	A	A	A	A

Intersection Summary			
Delay		7.0	
Level of Service		A	
Intersection Capacity Utilization	13.3%	ICU Level of Service	A
Analysis Period (min)	15		

# HCM Unsignalized Intersection Capacity Analysis

## 9: SW Alder St & SW 9th St

10/1/2013



Movement	EBL	EBT	EBR	WBL	WBT	WBR	NBL	NBT	NBR	SBL	SBT	SBR
Lane Configurations		↕			↕			↕			↕	
Volume (veh/h)	2	85	2	10	140	15	2	35	5	5	2	2
Sign Control		Free			Free			Stop			Stop	
Grade		0%			0%			0%			0%	
Peak Hour Factor	0.85	0.85	0.85	0.85	0.85	0.85	0.85	0.85	0.85	0.85	0.85	0.85
Hourly flow rate (vph)	2	100	2	12	165	18	2	41	6	6	2	2
Pedestrians												
Lane Width (ft)												
Walking Speed (ft/s)												
Percent Blockage												
Right turn flare (veh)												
Median type		None			None							
Median storage (veh)												
Upstream signal (ft)												
pX, platoon unblocked												
vC, conflicting volume	182			102			306	312	101	329	304	174
vC1, stage 1 conf vol												
vC2, stage 2 conf vol												
vCu, unblocked vol	182			102			306	312	101	329	304	174
tC, single (s)	4.1			4.1			7.1	6.5	6.2	7.1	6.5	6.2
tC, 2 stage (s)												
tF (s)	2.2			2.2			3.5	4.0	3.3	3.5	4.0	3.3
p0 queue free %	100			99			100	93	99	99	100	100
cM capacity (veh/h)	1393			1490			638	597	954	583	603	870

Direction, Lane #	EB 1	WB 1	NB 1	SB 1
Volume Total	105	194	49	11
Volume Left	2	12	2	6
Volume Right	2	18	6	2
cSH	1393	1490	627	634
Volume to Capacity	0.00	0.01	0.08	0.02
Queue Length 95th (ft)	0	1	6	1
Control Delay (s)	0.2	0.5	11.2	10.8
Lane LOS	A	A	B	B
Approach Delay (s)	0.2	0.5	11.2	10.8
Approach LOS			B	B

Intersection Summary			
Average Delay		2.2	
Intersection Capacity Utilization	24.5%		ICU Level of Service
Analysis Period (min)		15	A

# HCM Unsignalized Intersection Capacity Analysis

## 10: SE Edwards Dr & SW 5th St

10/1/2013



Movement	EBL	EBR	NBL	NBT	SBT	SBR
Lane Configurations						
Volume (veh/h)	5	245	325	10	0	10
Sign Control	Stop			Free	Free	
Grade	0%			0%	0%	
Peak Hour Factor	0.90	0.90	0.90	0.90	0.90	0.90
Hourly flow rate (vph)	6	272	361	11	0	11
Pedestrians						
Lane Width (ft)						
Walking Speed (ft/s)						
Percent Blockage						
Right turn flare (veh)						
Median type				None	None	
Median storage (veh)						
Upstream signal (ft)						
pX, platoon unblocked						
vC, conflicting volume	739	6	11			
vC1, stage 1 conf vol						
vC2, stage 2 conf vol						
vCu, unblocked vol	739	6	11			
tC, single (s)	6.4	6.2	4.1			
tC, 2 stage (s)						
tF (s)	3.5	3.3	2.2			
p0 queue free %	98	75	78			
cM capacity (veh/h)	298	1077	1608			
Direction, Lane #	EB 1	NB 1	SB 1			
Volume Total	278	372	11			
Volume Left	6	361	0			
Volume Right	272	0	11			
cSH	1024	1608	1700			
Volume to Capacity	0.27	0.22	0.01			
Queue Length 95th (ft)	28	22	0			
Control Delay (s)	9.8	7.7	0.0			
Lane LOS	A	A				
Approach Delay (s)	9.8	7.7	0.0			
Approach LOS	A					
Intersection Summary						
Average Delay			8.5			
Intersection Capacity Utilization		50.2%		ICU Level of Service		A
Analysis Period (min)		15				

# HCM Unsignalized Intersection Capacity Analysis

## 12: SW 5th St & SW Upland Dr

10/1/2013

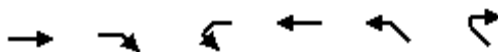









Movement	EBT	EBR	WBL	WBT	NWL	NWR
Lane Configurations	↻			↻	↻	
Sign Control	Stop			Stop	Stop	
Volume (vph)	0	70	0	0	45	0
Peak Hour Factor	0.98	0.98	0.98	0.98	0.98	0.98
Hourly flow rate (vph)	0	71	0	0	46	0
Direction, Lane #	EB 1	WB 1	NW 1			
Volume Total (vph)	71	0	46			
Volume Left (vph)	0	0	46			
Volume Right (vph)	71	0	0			
Hadj (s)	-0.57	0.00	0.23			
Departure Headway (s)	3.4	4.1	4.3			
Degree Utilization, x	0.07	0.00	0.05			
Capacity (veh/h)	1027	879	820			
Control Delay (s)	6.7	7.1	7.5			
Approach Delay (s)	6.7	0.0	7.5			
Approach LOS	A	A	A			
Intersection Summary						
Delay			7.0			
Level of Service			A			
Intersection Capacity Utilization			14.7%	ICU Level of Service	A	
Analysis Period (min)			15			

# HCM Unsignalized Intersection Capacity Analysis

## 29: SE Parks Dr & SE Edwards Dr

10/1/2013

						
Movement	NBL	NBR	SEL	SER	SWL	SWR
Lane Configurations						
Volume (veh/h)	75	5	20	200	5	2
Sign Control	Free		Free		Stop	
Grade	0%		0%		0%	
Peak Hour Factor	0.98	0.98	0.98	0.98	0.98	0.98
Hourly flow rate (vph)	77	5	20	204	5	2
Pedestrians						
Lane Width (ft)						
Walking Speed (ft/s)						
Percent Blockage						
Right turn flare (veh)						
Median type	None		None			
Median storage (veh)						
Upstream signal (ft)						
pX, platoon unblocked						
vC, conflicting volume			82		324	79
vC1, stage 1 conf vol						
vC2, stage 2 conf vol						
vCu, unblocked vol			82		324	79
tC, single (s)			4.1		6.4	6.2
tC, 2 stage (s)						
tF (s)			2.2		3.5	3.3
p0 queue free %			99		99	100
cM capacity (veh/h)			1516		661	981
<b>Direction, Lane #</b>	<b>NB 1</b>	<b>SE 1</b>	<b>SW 1</b>			
Volume Total	82	224	7			
Volume Left	0	20	5			
Volume Right	5	0	2			
cSH	1700	1516	729			
Volume to Capacity	0.05	0.01	0.01			
Queue Length 95th (ft)	0	1	1			
Control Delay (s)	0.0	0.8	10.0			
Lane LOS		A	A			
Approach Delay (s)	0.0	0.8	10.0			
Approach LOS			A			
<b>Intersection Summary</b>						
Average Delay			0.8			
Intersection Capacity Utilization			31.3%		ICU Level of Service	A
Analysis Period (min)			15			

# MEMORANDUM

**DATE:** 07 Aug 2012  
**TO:** Dundee TSP Project Management Team  
**FROM:** Carl Springer  
**SUBJECT:** Stakeholder Interview Summary for TSP Update

P# 11086-003-002

---

DKS conducted nine stakeholder interviews in July and August 2012. This memo summarizes the interview process and input, and provides recommendations for refinements to the public outreach strategy based on input received.

## ***Interview process and participants***

Participants were selected to complement the input that the Project Advisory Committee is providing. The following stakeholders were interviewed:

1. Nancy Ponzi, Ponzi Winery
2. Don Clements, Chehalam Park and Recreation District
3. Don Sundeen, former Mayor
4. Rollin Soles, Dundee Civic Association & Argyle Winery
5. Tom Edwards, Landowner; Larry Anderson, development representative
6. Mart Storm, local developer
7. Tom Mortimer, Bag Connection
8. Ken Johnston, 12 & Maple Wine Company
9. Rod Grinberg, major property representative

Each interview lasted between 30 minutes and 1 hour. The purpose of the interviews was to hear from participants about:

- How the transportation system affects the stakeholder's business/organization
- How the system works today
- Ideas about future projects
- Ideas for outreach during the TSP process





## ***Input from interviews***

Themes and highlights are summarized here.

### **Transportation interests**

**Access in mid-town Dundee.** Of all the circulation topics, this was most consistently mentioned by stakeholders. With all the future growth east of 99W, improved connections east of the highway will be required, along with upgraded traffic controls at the intersection with the highway. There are still differences of opinion about which street connection makes the most sense for a centralized east/west facility – whether it be 8<sup>th</sup> Street, 9<sup>th</sup> Street or 10<sup>th</sup> Street. Challenges with rail crossings were acknowledged, but stakeholder thought the existing crossings could be swapped for better locations, as needed. For truck access onto 9<sup>th</sup> Street – Worden Hills Road, ideally this intersection would be sized to serve turning movements for larger trucks.

**Creating a Main Street Business District.** Business owners along 99W generally wanted progress made in converting 99W to better serve those businesses, rather than through traffic. Several mentioned bringing forward strategies from the OR 99W Refinement Plan, which included frequent pedestrian crossing facilities, on-street parking, wider sidewalks, etc. to make the highway more suitable for pedestrians. One stakeholder would say this vision is consistent with the 2002 City Council Vision. Also included would be the undergrounding of pole mounted utilities, and consistent building design guidelines.

**Biking and walking.** Stakeholders agreed that providing biking and walking facilities in Dundee is important. Stakeholders had varying viewpoints about the quality of existing bike and pedestrian infrastructure. Most agreed that safe and convenient crossing improvements to the highway are important. Others wanted walking connections to the riverfront area, as well. One stakeholder mentioned the importance of replacing the ped / bike connection lost with the severing of Dayton Avenue at Edward Drive. Some sort of alternative connection is needed.

**Alternative Local Routes.** Several stakeholders suggested that parallel routes to the highway (and the bypass) are important to allow for short trips off of the highway. In this TSP, these include SW Alder Street and SE Maple Street extensions. There were differing opinions about whether these should be full street improvements for all modes, or just a trail connection for peds / bikes in the existing gaps.

**Battling Cynicism.** Several stakeholders have been disappointed by the lack of follow through with past plans – OR 99W Refinement Plan – and would like to see the City construct improvements on 99W to help demonstrate progress.

**Certainty.** Many stakeholders said that understanding future improvement plans and funding is important to their decision making and planning. Several property owners also commented about their lack of clarity about the improvement requirements and associated costs needed for developments within the City.

### **Transportation priorities**

When asked about priorities for transportation improvements in Dundee, stakeholders gave a variety of answers depending on their points of view. Some themes that were mentioned include:

- Develop comfortable and convenient biking and walking facilities that help to get people where they need to go and connect transit routes to homes and workplaces. Biking facilities need to serve a variety of cyclist types from brave commuters to children riding to school.



- Improve pedestrian crossings on 99W.
- Make sure trucks can use the primary east-west connections in town where it intersects 99W.
- Revisit several planned street extensions to see how they impact planned development, and if better options are now available.

### **Outreach and engagement**

Stakeholders generally said the City does a good job of engaging community members. There were no significant concerns about the existing practice, but several stakeholders wanted to be added to the notification list of upcoming events or news about the TSP update.



720 SW Washington St  
Suite 500  
Portland, OR 97205  
503.243.3500

## DRAFT MEMORANDUM #8

**DATE:** February 13, 2014

**TO:** Dundee TSP Update Project Management Team

**FROM:** Carl Springer, P.E., DKS Associates  
Ray Delahanty, AICP, DKS Associates  
Anastasia Roeszler, E.I.T., DKS Associates

**SUBJECT: Dundee Transportation System Plan Update  
DRAFT Alternatives Evaluation**

---

The purpose of this memorandum is to identify land use and transportation system alternatives and evaluate the solutions using the evaluation criteria developed in TM #3 Goals, Objectives, & Evaluation Criteria. These alternatives are intended to address ways to improve existing and new facilities and services, including different modes or combination of modes that could reasonably meet identified transportation needs.

### Evaluation Criteria

Transportation concepts and project alternatives developed through this Transportation System Plan update were evaluated by applying criteria that are based on the TSP's goals and objectives. These project level criteria provided a point-based technical rating method that was used to evaluate how well proposed design alternatives meet the objectives of the TSP.

### Methodology

Project alternatives were compared by summing (and weighting) the ratings for each potential project. Ratings for each criterion were based on a five-point scale, from +2 to -2, with +2 generally representing a clear positive impact relative to the criterion, and -2 representing a clear negative impact relative to the criterion. A score of 0 typically represents no impact on the criterion, and +1 and -1 represent minor positive and negative impacts. For example, Table 1 shows an example of how the System Connectivity criterion, which arises from the System Capacity and Mobility goal, was applied.

**Table 1: Evaluation Criteria and Scoring Methodology Example**

Evaluation Criteria	Evaluation Score	
<b>System Connectivity</b> Connection enhances system efficiency	+2	Improves system efficiency
	+1	Improves efficiency in a localized area, but has no impact on efficiency of the system
	0	No change
	-1	Improves efficiency of a localized area, but may detract from the efficiency of another location
	-2	Negative impact on system efficiency

The criteria and related scoring parameters generate an aggregate score that reflects each project’s effectiveness in addressing the TSP’s goal areas: mobility, livability, public and policy-maker support, transportation options, accessibility, environment, funding availability, safety, and economic impact. Note that each of the nine goal areas have a different set of between two and five criteria, and scoring was averaged at the goal level so that each goal would be weighted the same.

A complete list of the goals, evaluation criteria, and scoring parameters are included in the appendix to this memorandum.

### Solutions Identification Process

In the past, a typical transportation planning response to congestion was to expand streets, creating significant barriers to walking and biking and detracting from the livability, health, safety, and fiscal wellbeing of the community. Dundee’s approach for this update places more value on connectivity and access, and takes a multi-modal network-wide approach to identifying transportation system solutions. This approach enables more cost-effective solutions to improve transportation system operations and helps to encourage multiple travel options, increase street connectivity, and promote a more sustainable transportation system.

### Projects

The following section evaluates a set of potential transportation improvement projects identified through the PAC, community meetings, and other planning documents. Individual projects were broken down by mode and evaluated using the goals and objectives criteria discussed in the previous section.

In addition to these individual projects, Dundee desires better connections through downtown. Five downtown connectivity options were developed and evaluated as a complete package rather than by individual components. Each package contains improvements to existing roadways, new roadway connections, and some include intersection and rail crossing improvements.

New safety measures were evaluated at the Niederberger Road/Park Road and Highway 99W intersection. Two different alignment and intersection geometry options were evaluated and compared to determine which option is a better fit for this intersection.

### General Solutions

The following sections contain proposed solutions that were identified through other planning documents, community meetings, and through the PAC. Each solution was evaluated individually using the goals and objectives criteria identified in TM 3. Project scores can be found in the appendix.

### Driving Projects

Driving projects are listed below in Table 2 and illustrated in Figure 1. The gaps in the project numbers listed in Table 2 are either projects that were removed from consideration during the evaluation process or projects that are part of the downtown connectivity options evaluated later in this document. Projects are scored as either high, medium, or low priority. High priority projects scored above a four, medium priority projects scored between three and four, and low priority projects scored less than three. A breakdown of the scoring for each project is available in the appendix.

All of the new street projects between 5<sup>th</sup> and 7<sup>th</sup> and between 5<sup>th</sup> and 3<sup>rd</sup> (D2, D16, and D12) are dependent on redevelopment of the existing properties. D6 and D7 are outside the Dundee UGB and will need to be approved by Yamhill County.

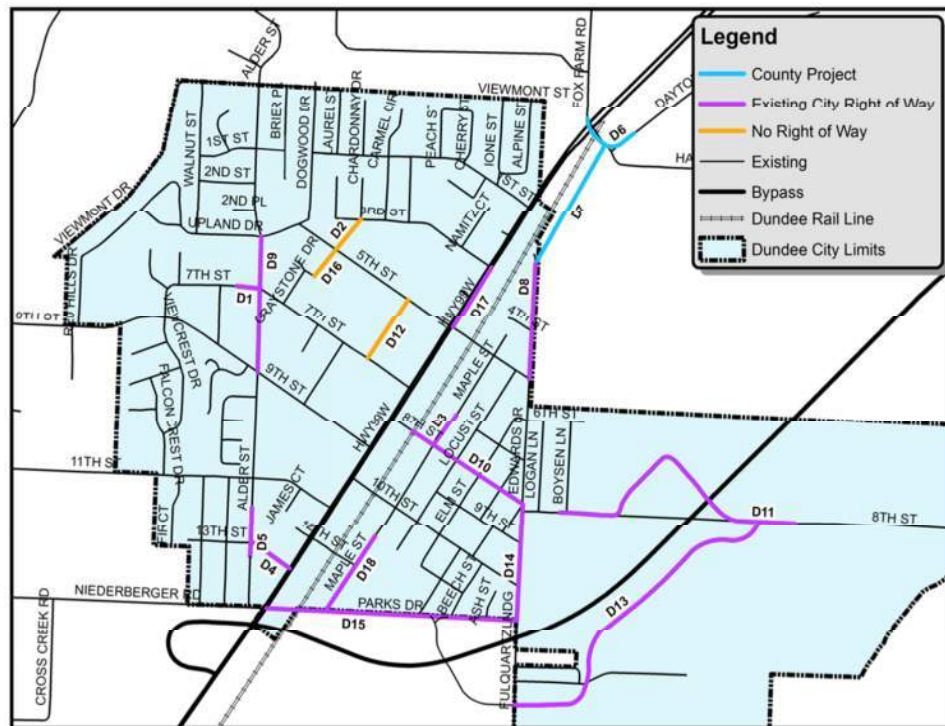

Figure 1: Driving Projects

Table 2: Driving Projects

Project #	Project Name	Project Description	Source	Score
D1	7th St Extension	7th St extension to Alder St	2003 TSP	HIGH
D2¶	New Street	New street from 3rd St to 5th St	2003 TSP	MED
D3	Maple St Extension	Maple St extension from 8th St to 7th St	2003 TSP	MED
D4	13th St	13th St - new street from Alder St to Hwy 99W	2003 TSP	HIGH
D5	Alder St Extension	Alder St extension to Hwy 99W	2003 TSP	HIGH
D6*†	Fox Farm Rd Realignment	Fox Farm Road Realignment	2003 TSP	HIGH
D7†	Edwards Rd Extension	Edwards Rd Extension to Dayton Ave	2003 TSP	MED
D8	Edwards Rd Reconstruction	Edwards Rd reconstruction between 2nd St and 5th St	2003 TSP	HIGH
D9	Alder St Reconstruction	Alder St reconstruction between 9th St and Upland Dr	2003 TSP	HIGH
D10	8th St Reconstruction	8th St reconstruction between railroad and Edwards Rd	2003 TSP	MED
D11	8th St Connection	8th Street connection to Riverside	Bypass	HIGH
D12¶	New Street	New street from 5th St to 7th St	2003 TSP	MED
D13	North South Parkway	North South Parkway	Riverside Plan	HIGH
D14	Edwards St Improvement	Improvement of Edwards to collector standards (8th-Parks)	Riverside Plan	HIGH
D15	Parks Improvement	Improvement of Parks to collector standards (99W to Edwards)	Riverside Plan	HIGH
D16¶	New Street	5th St to 7th St Connection	Meetings	MED
D17‡	99W Accel Lane	99W Acceleration Lane from 5th to 3rd	Meetings	LOW
D18	Maple St Reconstruction	Reconstruct Maple St between 11 <sup>th</sup> and Parks	Meetings	MED

\*County Facility

†Outside UGB

‡ODOT Facility

¶No Right of Way/Subject to redevelopment

## Sidewalk Projects

Dundee lacks sidewalks on many of its streets. For the purpose of the TSP, only sidewalks on collector streets were included in the inventory of sidewalk projects. Missing sidewalks on local streets can be addressed though code changes.

Sidewalk projects are listed below in Table 3 and illustrated in Figure 2. All of these projects scored very high. A full breakdown of the scoring and preliminary cost estimates can be found in the appendix.

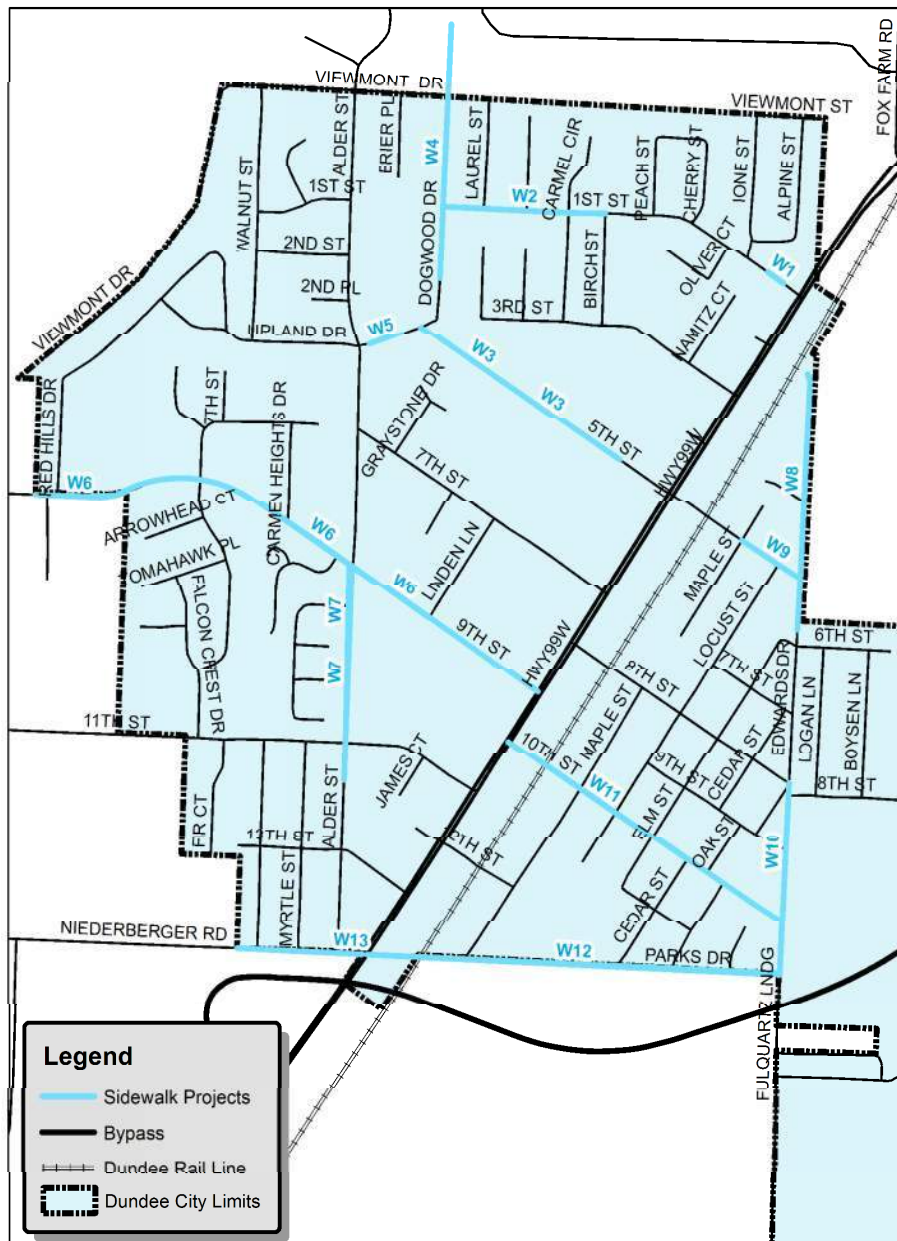

Figure 2: Sidewalk Projects



Table 3: Sidewalk Projects

Project	Project Name	Project Description	Source
W1	SW 1st St Sidewalks	1st St - sidewalks between Hwy 99W and Lone St	2003 TSP
W2	SW 1st St Sidewalks	1st St - sidewalks on south side between Dogwood Dr and Birch St	2003 TSP
W3	SW 5th St Sidewalks	5th St - sidewalks on north side along park frontage to Dogwood Dr and infill on S side	2003 TSP
W4	Dogwood St Sidewalks	Dogwood Dr sidewalk infill	2003 TSP
W5	SW Upland Dr Sidewalks	Upland Dr sidewalk infill	2003 TSP
W6	SW 9th St Sidewalks	9th St - sidewalks on north side from 99W to Viewcrest, infill sidewalks on south side	Meetings 2003 TSP
W7†	SW Alder St Sidewalks	Alder St - sidewalks on both sides from Upland St to just past 11 <sup>th</sup> St	2003 TSP
W8*	SE Edwards Dr Sidewalks	Edwards Dr sidewalks on both sides from 6 <sup>th</sup> to 2 <sup>nd</sup>	Meetings
W9	SE 5th St Sidewalks	SE 5th St infill sidewalks	Meetings
W10*	SE Edwards Dr Sidewalks	Edwards Dr infill sidewalks from 8 <sup>th</sup> to Parks	Meetings
W11	SE 10th St Sidewalks	10th St - sidewalks on north side from Hwy 99W to Cedar St and near Edward St, all along south side	2003 TSP
W12*	SE Parks Rd Sidewalks	Parks Rd - sidewalks on both sides between Hwy 99W and Edwards Rd	2003 TSP
W13	SW Niederberger Rd Sidewalks	Niederberger Rd sidewalks on both sides within city limits	Meetings

\*These sidewalks can be completed as part of collector upgrade projects. See D8, D14, and D15.

†Sidewalks between Upland and 9<sup>th</sup> to be completed as part of D9

## Traffic Control

Traffic control projects are listed below in Table 4 illustrated in Figure 3. Traffic control projects that are part of one of the Downtown Connectivity Options were not included in this evaluation. In Table 4, project numbers beginning with “I” refer to intersection projects, “R” refers to rail projects, and “C” refers to pedestrian crossing projects. The pedestrian crossing projects scored considerably higher than the intersection and rail projects, probably because many of the goals and objectives are geared toward livability and multi-modal travel options. Since these projects encompass traffic control approaches that are very different and serve different purposes, they were not compared against each other. A breakdown of the scoring for each project is available in the appendix.

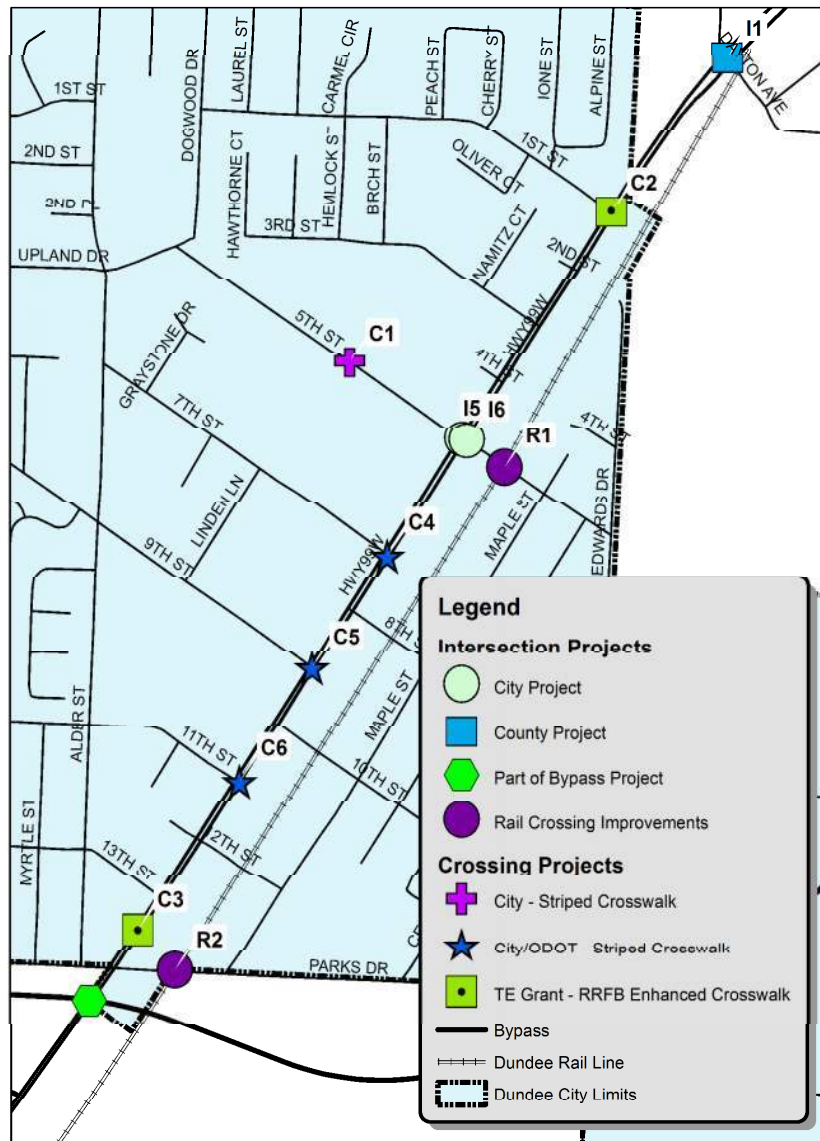

Figure 3: Traffic Control Projects

Table 4: Traffic Control

Project #	Intersection	Project Description	Source
I1*	Fox Farm-Dayton Road/Hwy 99W	Fox Farm-Dayton Road/Hwy 99W Traffic Signal	2003 TSP
I5†	5 <sup>th</sup> St/Hwy 99W	5 <sup>th</sup> Street phasing/signal upgrade (improve side street service)	Open House
I6†	5 <sup>th</sup> St/Hwy 99W	Westbound right turn lane (5th/99W)	PAC
R1	Parks Rd	Parks Rd RR Crossing Gates	Meetings
R2	5 <sup>th</sup> St	5 <sup>th</sup> St RR Crossing Gates	2003 TSP
C1	5 <sup>th</sup> St	5 <sup>th</sup> St - midblock crosswalk to connect post office with school and park	2003 TSP
C2‡	Hwy 99W/1 <sup>st</sup> St	Crossing enhancements and RRFB	ODOT
C3‡	Hwy 99W/13 <sup>th</sup> St	Crossing enhancements and RRFB	ODOT
C4	Hwy 99W/7 <sup>th</sup> St	Striped Crosswalk	Meetings
C5	Hwy 99W/9 <sup>th</sup> St	Striped Crosswalk	Meetings
C6	Hwy 99W/11 <sup>th</sup> St	Striped Crosswalk	Meetings

\*County Facility

†ODOT Facility

‡Part of ODOT TE Grant Project

## Bicycle and Shared-Use Path Projects

Bicycle projects are listed below in Table 5 and illustrated in Figure 4. Bicycle projects may include different treatments, such as bike lanes, which are more appropriate for busier, higher speed roads, and shared-roadway markings. All of the bicycle projects scored relatively high and the scores were very close. The highest scoring project was the 9<sup>th</sup>/Worden Hill Road on-street trail. A breakdown of scoring for each project is available in the appendix.

Shared-use path projects are listed below in Table 6 and illustrated in Figure 4. All of the shared-use path projects scored very high and the scores were very close. The shared-use paths that scored the highest were generally those that can provide a needed connection between neighborhoods. None of the shared-use path projects scored lower than eight. A breakdown of scoring for each project is available in the appendix.

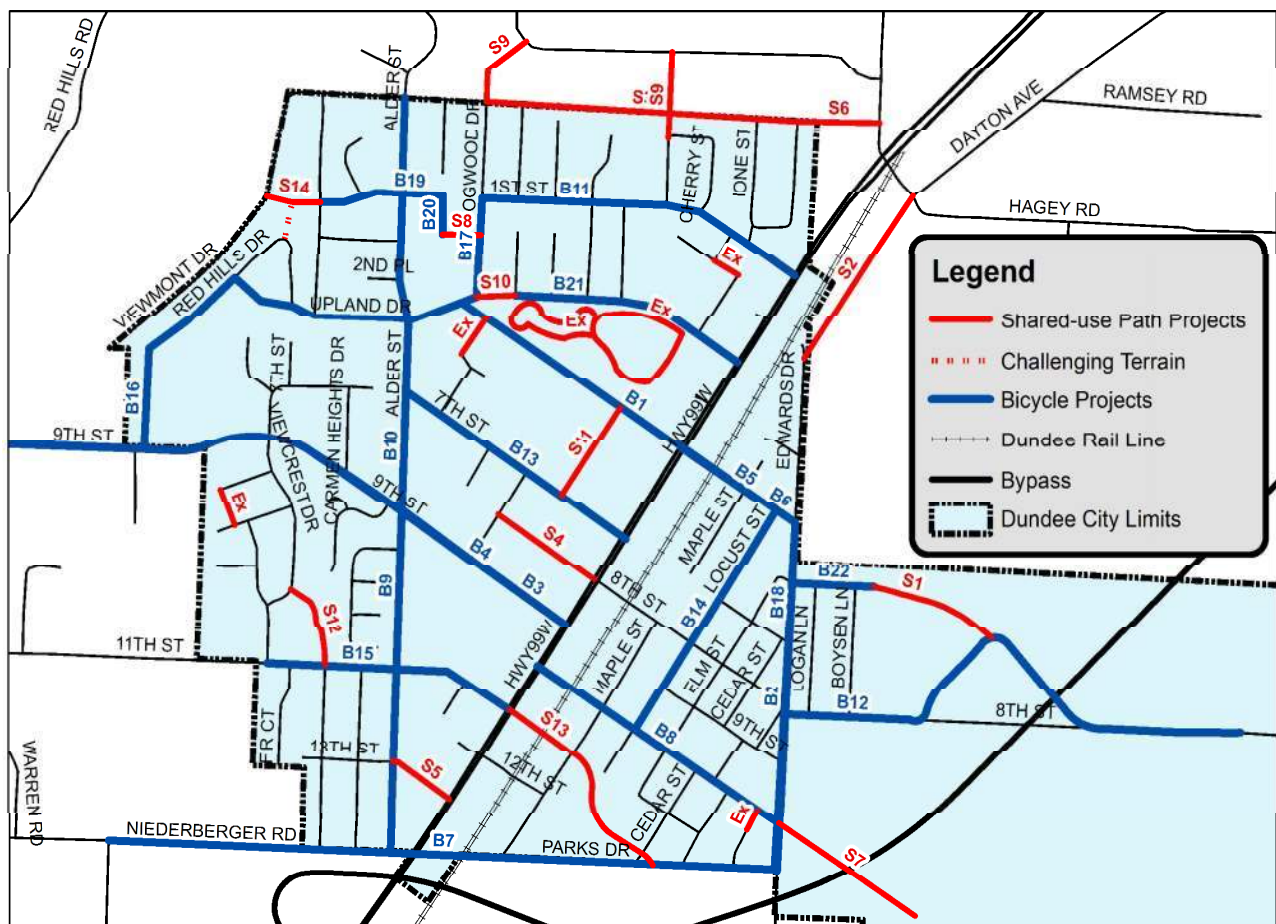

Figure 4: Bicycle and Shared Use Path Projects

Table 5: Bicycling Projects

Project #	Project Location	Project Description	Source
B1	5th St	Bike lanes from Alder to 99W	2003 TSP
B2*	Edwards Rd	Bike lanes south of 5th St	2003 TSP
B3	9th/Worden Hill Road	9th/Worden Hill Road on-street trail	CRPD
B4**	9th/Worden Hill Road	9th/Worden Hill Road bike lanes	CRPD
B5	5th St	5th Street bike lanes (east of 99W)	CRPD
B6	5th St	5th Street shared roadway (east of 99W)	CRPD
B7*	Parks Dr	Bike Lanes on Parks Dr	New
B8	10th St	10th St shared roadway	New
B9*	Alder Street	Alder Street bike lanes	New
B10	Alder Street	Alder Street shared roadway	New
B11	1st Street	1st Street shared roadway from Highway to Dogwood Dr	New
B12	8th Street	8th Street bike lanes (Riverside)	New
B13	7th Street	7th Street shared roadway	New
B14	Locust Street	Locust Street shared roadway	New
B15	11th Street	11th Street shared roadway (west of 99W)	New
B16	Redhills Drive	Redhills Drive shared roadway	New
B17	Dogwood Drive	Dogwood Drive shared roadway	New
B18	Edwards Drive	Edwards Drive shared roadway	New
B19	1st Street	1st Street shared roadway from Brier Pl to Walnut St	New
B20	Brier Place	Brier Place shared roadway	New
B21	3rd Street	3rd Street shared roadway	New
B22	6th Street	6th Street shared roadway	New

\*These projects can be completed as part of collector upgrade projects D8, D9, D14, and D15.

\*\*If road widened to collector standards

Table 6: Shared-Use Path Projects

Project #	Project Location	Project Description	Source
S1	6th St	6th Street trail extension to Riverside	Meetings
S2*	Dayton Ave - Edwards Dr	Dayton Avenue-Edwards Drive connection	Meetings
S3	Viewmont Trail	Viewmont trail/linear park along northern city limit between Dogwood Dr and lone St	Meetings
S4	8th St	8th Street west of Hwy 99W conversion to off-street path	Meetings
S5	13th St	13th Street west of Hwy 99W conversion to off-street path	Meetings
S6*	Viewmont to Fox Farm Rd	Trail connection between Viewmont and Fox Farm Road	Open House
S7	10th St at Bypass	Bike/ped undercrossing of Bypass at 10th Street	Riverside Plan
S8	1st St Connection	1st St SUP Connection between Dogwood Dr and Brier Pl	Meetings
S9	SUP Connection to Subdivision	SUP Connection to Subdivision north of city limits	Meetings
S10	3rd St Connection	3rd St Connection to Upland Dr through existing right of way	Meetings
S11	7th to 5th Connection	5th to 7th St connection to school	Meetings
S12	Viewcrest Connection	Viewcrest to Parking Lot off of 11 <sup>th</sup> St	Meetings
S13	11th St Connection	11th St SUP Connection to Fulquatz/Parks Rd intersection – this project replaces the 11 <sup>th</sup> St road connection	Meetings
S14	T Connection	T Connection from Walnut to Viewmont and Red Hills Dr using existing right of way	Meetings

\*Outside UGB

## Transit Projects

Transit projects are listed in Table 7 below. All of the transit projects would involve coordination with ODOT, Yamhill County Transit, and other agencies. In general transit projects scored relatively low, with scores ranging between two and four. A breakdown of scoring for each project is available in the appendix.

**Table 7: Transit Projects**

Project #	Project Location	Project Description	Source
T1*	Hwy 99W	Park and ride lots on Hwy 99W and moderate level of express bus service (30-minute peak, 60-minute off-peak)	2003 TSP
T2*	Hwy 99W	Improve Hwy 99W to serve the express bus transit stops	2003 TSP
T3*	Hwy 99W	Concentrate park-and-ride lots to support express and local bus service	2003 TSP
T4	City Wide	Use local buses to feed the inter-city express bus system	2003 TSP
T5†	McMinnville	Consider a commuter rail line from McMinnville to the proposed Wilsonville/Beaverton commuter rail line.	2003 TSP
T6	Riverside	Transit service to Riverside area	Meetings
T7	City Wide	Transit loop service (using Alder, Edwards)	Open House
T8*	Hwy 99W	Second pair of stops on 99W	Meetings

\*ODOT Facility

†Outside UGB

## Parking Projects

The project team evaluated only two parking projects. SW 8<sup>th</sup> Street at Highway 99W is currently unimproved, and is being considered as a possible off-street path location. This project would add some parking along the same right of way. Similarly, the 10<sup>th</sup> Street parking project would add parking along the unimproved 10<sup>th</sup> Street alignment. Using the evaluation objectives developed in TM 3, these projects scored relatively low. A breakdown of the scoring for this project is available in the appendix.

**Table 8: Parking Projects**

Project #	Project Location	Project Description	Source
P1	8 <sup>th</sup> Street	8 <sup>th</sup> Street (west) parking capacity	Open House
P2	10 <sup>th</sup> Street	10 <sup>th</sup> Street Parking Near Women's Club	Meetings



### **Downtown Connectivity Options**

Five downtown connectivity packages were developed that include a set of potential transportation projects with an unconstrained budget. The packages consist of a combination of new and previously planned projects for the transportation system that attempt to address the gaps and deficiencies previously identified in Technical Memorandum #6 – Future Needs Analysis. The five options include four direct connections across 99W, and one alternative with no direct connection but with other improvements.

### Option 1a – 10<sup>th</sup> St Connection

Option 1a includes extensions of two streets west of Highway 99W, and the extension of several local streets to the east of Highway 99W. This option does not include a traffic signal, railroad crossing gates, or other improvements at Highway 99W. The solutions recommended for Option 1a are summarized in Table 9 and illustrated in Figure 5. Project numbers are denoted with a “D” to represent driving projects.

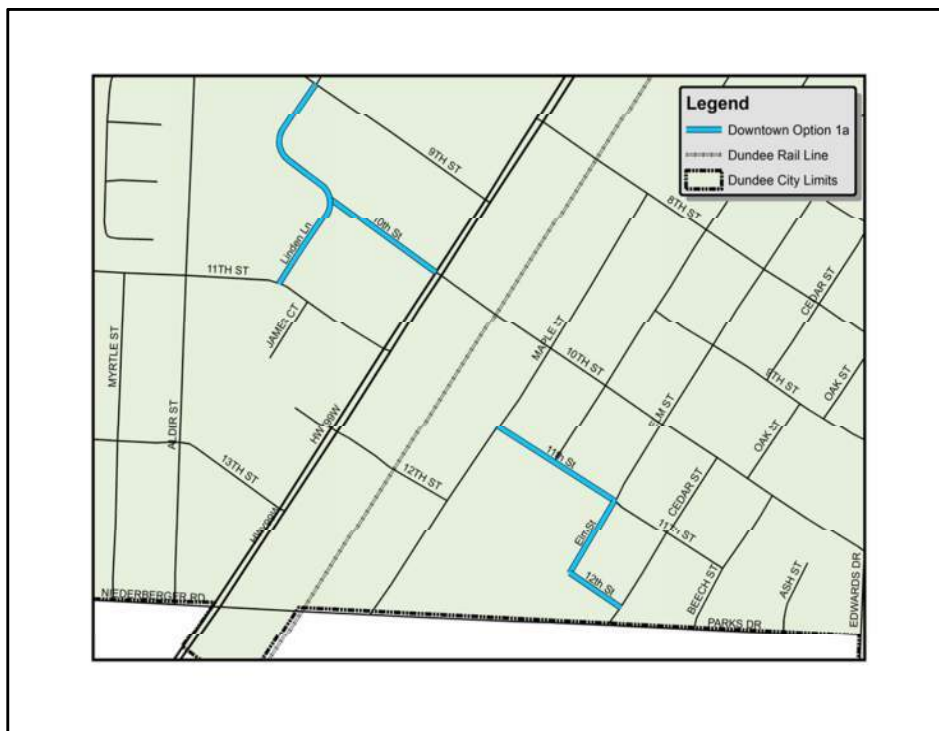

Figure 5: Downtown Option 1a

Table 9: Option 1a – 10<sup>th</sup> St Connection

Project #	Project Location	Project Description	Source
<b>Connectivity West of Highway 99W</b>			
D19	Linden Lane Extension	Linden Lane extension from 9 <sup>th</sup> St to 11 <sup>th</sup> St	Meetings
D20	10 <sup>th</sup> St Connection	10 <sup>th</sup> St extension from Linden Lane to Hwy 99W	Meetings
<b>Connectivity East of Highway 99W</b>			
D21	12 <sup>th</sup> St Extension	12 <sup>th</sup> St extension from Elm St to Cedar St	2003 TSP
D22	Elm St Extension	Elm St extension from 11 <sup>th</sup> St to 12 <sup>th</sup> St	2003 TSP
D23	11 <sup>th</sup> St Extension	11 <sup>th</sup> St Extension from Elm St to Maple St	2003 TSP

### Option 1b – 10<sup>th</sup> Street Upgrade

Option 1b includes all of the improvements described in Option 1a with the addition of a potential traffic signal at 10<sup>th</sup> Street (dependent on meeting traffic signal warrants), railroad crossing gates at the rail crossing just east of Highway 99W, and widening of 10<sup>th</sup> St between Highway 99W and Edwards Street. The solutions recommended for Option 1b are summarized in Table 10 and illustrated in Figure 6. Project numbers are denoted with a “D” to represent driving projects, an “T” to represent intersection projects, and “R” to represent rail projects.

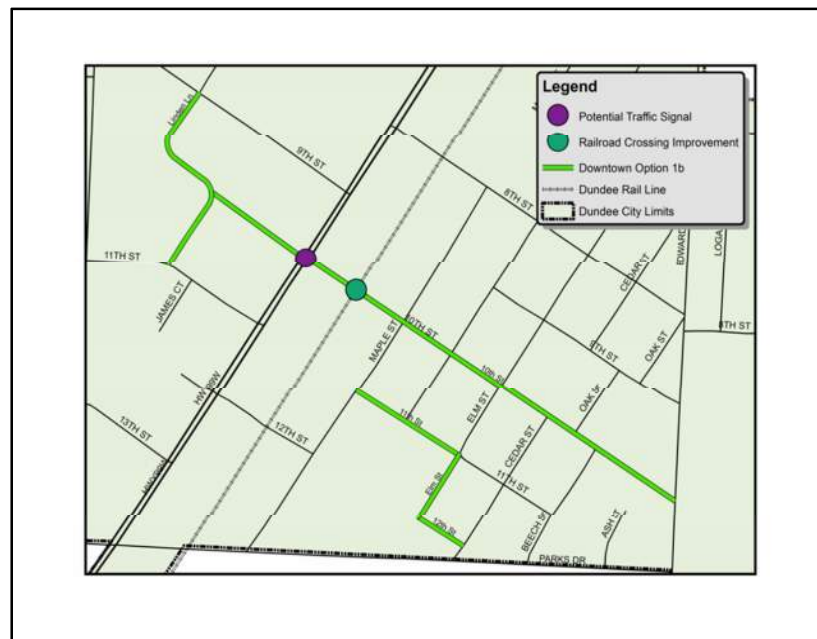

Figure 6: Downtown Option 1b

Table 10: Option 1b - 10<sup>th</sup> Street Upgrade

Project #	Project Location	Project Description	Source
<b>Connection Across Highway 99W</b>			
D24	10 <sup>th</sup> St	Widen and reconstruct 10 <sup>th</sup> St between Hwy 99W and Edwards St	PAC
I2	10 <sup>th</sup> St/Hwy 99W	10 <sup>th</sup> St/Hwy 99W Traffic Signal	2003 TSP
R3	10 <sup>th</sup> St	10 <sup>th</sup> St RR Crossing Gates	2003 TSP
<b>Connectivity West of Highway 99W</b>			
D19	Linden Lane Extension	Linden Lane extension from 9 <sup>th</sup> St to 11 <sup>th</sup> St	Meetings
D20	10 <sup>th</sup> St Connection	10 <sup>th</sup> St extension from Linden Lane to Hwy 99W	Meetings
<b>Connectivity East of Highway 99W</b>			
D21	12 <sup>th</sup> St Extension	12 <sup>th</sup> St extension from Elm St to Cedar St	2003 TSP
D22	Elm St Extension	Elm St extension from 11 <sup>th</sup> St to 12 <sup>th</sup> St	2003 TSP
D23	11 <sup>th</sup> St Extension	11 <sup>th</sup> St Extension from Elm St to Maple St	2003 TSP

### Option 2 – 11<sup>th</sup> Street Direct Connection

Option 2 includes the same Linden Lane improvement west of Highway 99W found in Options 1a and 1b. Option 2 extends 11<sup>th</sup> Street from Highway 99W to Parks Drive, connecting to the Fulquartz Landing extension that will be built with the Newberg Dundee Bypass, and includes a potential traffic signal (if warrants are met) and railroad crossing improvements. Due to railroad crossing spacing rules, the public crossings at 10<sup>th</sup> Street and 12<sup>th</sup> Street would need to be closed. This option provides a direct connection to Parks Drive unlike Options 1a and 1b. The solutions recommended for Option 2 are summarized in Table 11 and illustrated in Figure 7. Project numbers are denoted with a “D” to represent driving projects, an “I” to represent intersection projects, and “R” to represent rail projects.

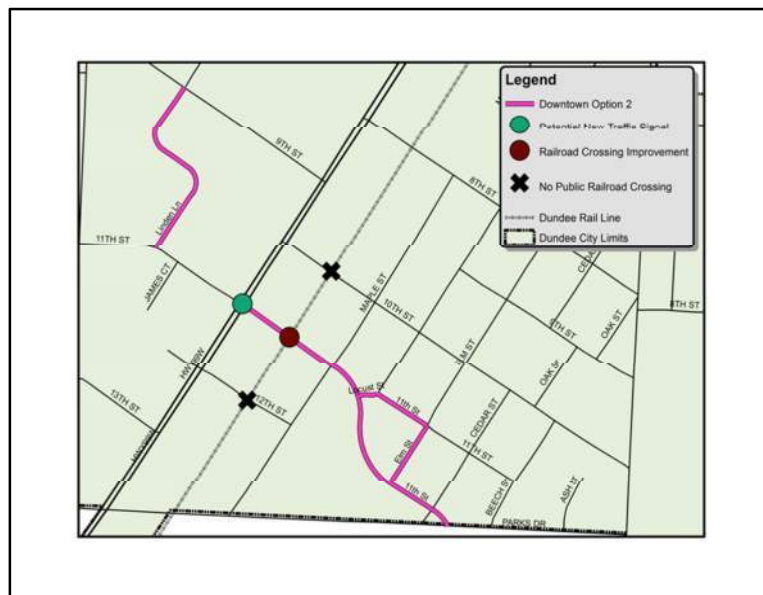

Figure 7: Downtown Option 2

Table 11: Option 2 - 11th Street Direct Connection

Project #	Project Location	Project Description	Source
<b>Connection Across Highway 99W</b>			
D25	11 <sup>th</sup> St Extension	11 <sup>th</sup> St extension from Hwy 99W to Fulquartz Landing/Parks Rd intersection	PAC
I7	11 <sup>th</sup> St/Hwy 99W	11 <sup>th</sup> St/Hwy 99W Traffic Signal	Meetings
R4	11 <sup>th</sup> St	11 <sup>th</sup> St RR Crossing Gates	Meetings
<b>Connectivity West of Highway 99W</b>			
D19	Linden Lane Extension	Linden Lane extension from 9 <sup>th</sup> St to 11 <sup>th</sup> St	Meetings
<b>Connectivity East of Highway 99W</b>			
D26	Locust St Extension	Locust St extension to 11 <sup>th</sup>	Meetings
D22	Elm St Extension	Elm St extension from 11 <sup>th</sup> St to 12 <sup>th</sup> St	2003 TSP

### Option 3 – 11<sup>th</sup> Street Connection to Cedar

Option 3 includes all of the east side connections in Options 1a and 1b as well as the Linden Lane extension described in Options 1a, 1b, and 2. Option 3 also includes extension of 11<sup>th</sup> St from Highway 99W to Maple Street, a traffic signal on Highway 99W at 11<sup>th</sup> Street (if warrants are met), and rail crossing improvements on 11<sup>th</sup> Street. Due to railroad crossing spacing rules, the public crossings at 10<sup>th</sup> Street and 12<sup>th</sup> Street would need to be closed. The solutions recommended for Option 3 are summarized in Table 12 and illustrated in Figure 8. Project numbers are denoted with a “D” to represent driving projects, an “I” to represent intersection projects, and “R” to represent rail projects.

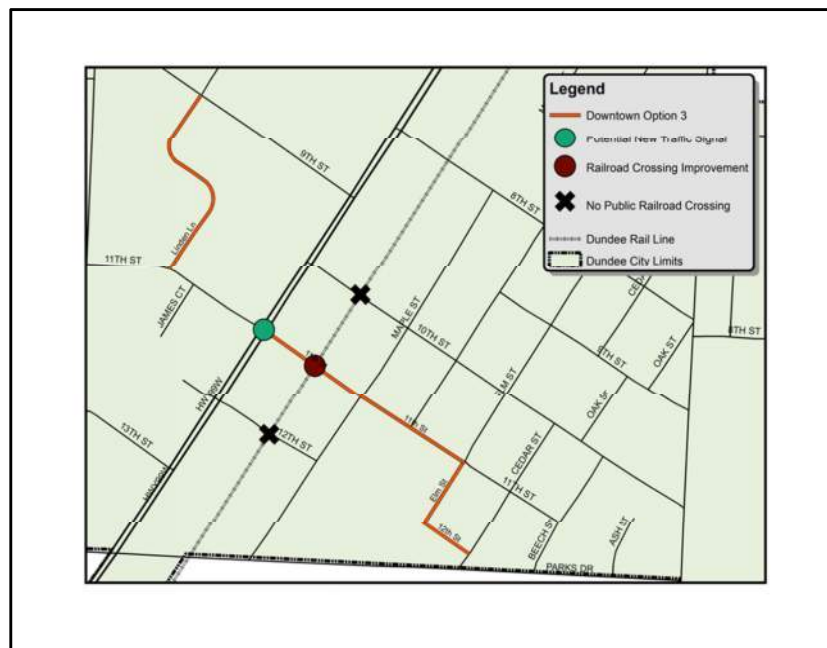

Figure 8: Downtown Option 3

Table 12: Option 3 - 11th Street Connection to Cedar

Project #	Project Location	Project Description	Source
<b>Connection Across Highway 99W</b>			
D27	11 <sup>th</sup> St Extension	11th St Extension from Hwy 99W to Maple	PAC
I7	11 <sup>th</sup> St/Hwy 99W	11 <sup>th</sup> St/Hwy 99W Traffic Signal	Meetings
R4	11 <sup>th</sup> St	11 <sup>th</sup> St RR Crossing Gates	Meetings
<b>Connectivity West of Highway 99W</b>			
D19	Linden Lane Extension	Linden Lane extension from 9 <sup>th</sup> St to 11 <sup>th</sup> St	Meetings
<b>Connectivity East of Highway 99W</b>			
D21	12 <sup>th</sup> St Extension	12 <sup>th</sup> St extension from Elm St to Cedar St	2003 TSP
D22	Elm St Extension	Elm St extension from 11 <sup>th</sup> St to 12 <sup>th</sup> St	2003 TSP
D23	11 <sup>th</sup> St Extension	11 <sup>th</sup> St Extension from Elm St to Maple St	2003 TSP

### Option 4 – 9<sup>th</sup> Street to Riverside

Option 4 includes the east side connections in Options 1a and 1b as well as the Linden Lane extension described in all of the previous connections. Option 4 also includes extension of 9<sup>th</sup> St from Highway 99W to Locust Street and from Edwards Drive to 8<sup>th</sup> Street, a traffic signal on Highway 99W at 9<sup>th</sup> Street (if warrants are met), and rail crossing improvements on 9<sup>th</sup> Street. Due to railroad crossing spacing rules, the public crossing at 10<sup>th</sup> Street would need to be closed, along with the existing 8<sup>th</sup> Street closure. The solutions recommended for Option 4 are summarized in Table 13 and illustrated in Figure 9. Project numbers are denoted with a “D” to represent driving projects, an “I” to represent intersection projects, and “R” to represent rail projects.

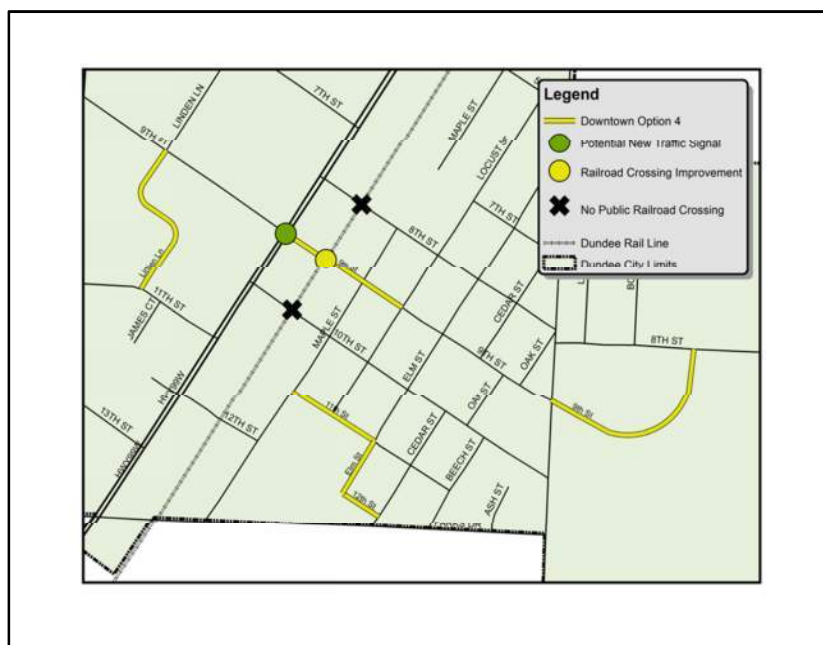

Figure 9: Downtown Option 4

Table 13: Option 4 - 9<sup>th</sup> Street Connection to Riverside

Project #	Project Location	Project Description	Source
<b>Connection Across Highway 99W</b>			
D28	9 <sup>th</sup> St Extension	9th St Extension from Hwy 99W to Locust and Edwards to 8th	Meetings
I8	9 <sup>th</sup> St/Hwy 99W	9 <sup>th</sup> St/Hwy 99W Traffic Signal	Meetings
R5	9 <sup>th</sup> St	9 <sup>th</sup> St RR Crossing Gates	Meetings
<b>Connectivity West of Highway 99W</b>			
D19	Linden Lane Extension	Linden Lane extension from 9 <sup>th</sup> St to 11 <sup>th</sup> St	Meetings
<b>Connectivity East of Highway 99W</b>			
D21	12 <sup>th</sup> St Extension	12 <sup>th</sup> St extension from Elm St to Cedar St	2003 TSP
D22	Elm St Extension	Elm St extension from 11 <sup>th</sup> St to 12 <sup>th</sup> St	2003 TSP
D23	11 <sup>th</sup> St Extension	11 <sup>th</sup> St Extension from Elm St to Maple St	2003 TSP

## Downtown Option Evaluation

Using the TSP goals set forth in TM 3, the Downtown connectivity options were evaluated and compared to one another (see Table 14). Each goal was weighted equally for the purposes of this analysis. The 11<sup>th</sup> Street connections, Options 2 and 3, scored the highest, with Option 3 scoring 5.7, and Option 2 scoring 5.2. Options 1b and 4 tied at 4.2, and Option 1a scored the lowest at 2.5.

Overall, the primary differences in scoring of the options were related to mobility and connectivity, availability of right of way, and environmental impact. Each option was evaluated separately using traffic modeling software to determine its impact on traffic circulation and mobility.

**Table 14: Downtown Option Analysis**

TSP Goals	Downtown Option 1a 10 <sup>th</sup> Street Connection	Downtown Option 1b 10 <sup>th</sup> Street Upgrade	Downtown Option 2 11 <sup>th</sup> Street Direct Connection	Downtown Option 3 11 <sup>th</sup> Street Connection to Cedar	Downtown Option 4 9 <sup>th</sup> Street Connection to Riverside
Goal 1: System Capacity and Mobility	0.5	0.5	2	2	1
Goal 2: Livability	0	0	0	0	0
Goal 3: Coordination	0.5	0.5	0.5	0.5	0.5
Goal 4: Travel Options	0	0.2	0.2	0.2	0.2
Goal 5: Accessibility	0.75	0.75	0.5	0.75	0.5
Goal 6: Environment	0	0	0	0	0
Goal 7: Timely Provision and Funding of Transportation Facilities and Services	0.5	1	0.5	1	1
Goal 8: Safety	0	1	1	1	1
Goal 9: Economic Development	0.25	0.25	0.5	0.25	0
<b>Total Score</b>	<b>2.5</b>	<b>4.2</b>	<b>5.2</b>	<b>5.7</b>	<b>4.2</b>
<b>Rank</b>	<b>4</b>	<b>3</b>	<b>2</b>	<b>1</b>	<b>3</b>
<b>Estimated Cost (Millions)</b>	<b>\$3.10</b>	<b>\$5.87</b>	<b>\$4.80</b>	<b>\$3.68</b>	<b>\$5.93</b>



## Niederberger Road/Parks Drive and Highway 99W Realignment

Two options were evaluated for the Niederberger Road/Parks Drive and Highway 99W intersection. This intersection is a skewed, two-way stop-controlled intersection. Two realignment options were proposed to improve safety and operations at this intersection. The first option involves realigning Niederberger Road and Parks Road to create an offset intersection. The second option involves adding slip lanes for right turns onto Highway 99W.

Using the TSP goals set forth in TM 3, both of the Niederberger Road/Parks Drive options were evaluated. Both options scored within a quarter of a point of each other with the Realignment option scoring slightly higher. The primary differences between the two options were safety and the impact on existing land use.

**Table 15: Niederberger Road - Parks Drive Realignment**

TSP Goals	Niederberger Road/Parks Drive at Hwy 99W Realignment	Niederberger Road/Parks Drive at Hwy 99W Slip Lanes
Goal 1: System Capacity and Mobility	0.5	0.5
Goal 2: Livability	0.33	0.33
Goal 3: Coordination	0.5	0.5
Goal 4: Travel Options	0	0
Goal 5: Accessibility	0.5	0.5
Goal 6: Environment	0	0
Goal 7: Timely Provision and Funding of Transportation Facilities and Services	0.5	0.5
Goal 8: Safety	2	1
Goal 9: Economic Development	-0.25	0.5
<b>Total Score</b>	<b>4.08</b>	<b>3.85</b>
<b>Rank</b>	<b>1</b>	<b>2</b>

### Highway 99W/5<sup>th</sup> Street Right Turn Lane

Highway 99W and 5<sup>th</sup> Street is a problematic intersection in downtown Dundee. One proposed solution is to add a right turn lane on westbound 5<sup>th</sup> street to accommodate the large number of right turns expected in the future. Without improvement, this intersection does not meet mobility targets for 2035 peak seasonal traffic, or 2035 average peak hour traffic. Analysis shows that the intersection will meet mobility targets under both traffic conditions if a westbound right turn lane is added.

Intersection	Mobility Target	No-build Condition Peak Seasonal		Westbound Right Turn Lane Peak Seasonal	
		V/C Ratio	LOS	V/C Ratio	LOS
Highway 99W/5 <sup>th</sup> Street	0.85	0.91	D	0.78	C

Scenarios not meeting the mobility standard are shaded in black.

### Projects Completed Since the 2003 TSP

Dundee has completed several transportation projects since the 2003 TSP, some that were directly identified in the 2003 TSP, and some that are modified from projects identified in the previous TSP. A list of these projects is provided in the Appendix.

### Planned but Unconstructed Projects

Transportation projects that were previously identified in the 2003 TSP, but have not been constructed were reviewed to identify overlap with known gaps and deficiencies of the transportation system. The previously planned projects that would complement the goals and policies of the Dundee TSP Update were carried forward with this TSP update, while other projects were modified to better complement the updated goals, or excluded altogether. The solutions that were identified as a project that would adequately meet the goals of this TSP update are shown in the following sections along with projects identified in the Riverside Plan, projects that were identified through public meetings, and projects identified by the PAC.

## Appendix

### Completed Projects Since 2003 TSP

1. Arrowhead, Tomahawk, and View Crest streets (including sidewalks both sides) were completed as part of a subdivision(s) – there are no sidewalk gaps.
2. Highway frontage improvements, Neiderberger, Alder (including curb and sidewalk) next to West End buildings project. City paid developer to complete curb and sidewalk improvement (quarter street improvements) to the west side of Alder Street opposite of the project.
3. City project (SCA grant) 11th Street widening. Curb and sidewalk completed on south side of 11th Street between James Court and 99W. Curb completed on north side of 11th Street between Alder Street and 99W, and sidewalk EXCEPT about 200 feet eastward from Alder Street where the right of way is 50' wide.
4. Complete sidewalk on south side of 5th Street between Locust and Edwards (part of SCA grant) and complete curb and sidewalk on west side of Edwards between 5th and 8th (ARRA grant).
5. 5th Street/Highway 99W intersection traffic signal project (ODOT), includes new turning lane on 5th Street eastbound approaching 99W, new sidewalk on the east side of 99W from a point about 300' south of 5th Street (Argyle Winery property) to the 4th Street intersection.
6. New streets, Graystone Drive and Graystone Place, pedestrian path connection between Graystone Place and 5th Street, and new curb and sidewalk on the north side 7th Street, and new curb on the south side of 5th Street and the east side of Upland Drive, and curb and sidewalk on the west side of Upland Drive as part of a subdivision. Infill sidewalks installed as homes are built.
7. 1st Street and Brier street improvements in the Vineyard Estates subdivision, curb on east side of Alder Street (next to Vineyard Estates subdivision), curb on east side of Dogwood from 5th to 1st ,curb on west side of Dogwood from 5th to a point about 100' north of the 1st Street intersection, sidewalk on the east side of Dogwood from 5th to a point about 400' north of 5th Street. Infill sidewalks installed as homes are built.
8. Curb and sidewalk installed on the north side of 1st Street between Dogwood and Carmel Circle (SCA grant).
9. Oliver Court completed for new subdivision.
10. Namitz Court completed for new subdivision. Pedestrian walkway connection between Namitz and Oliver.
11. Sidewalk installations on both sides of 1st Street near 99W intersection. New curb and sidewalk along the east side of 99W adjacent to new gas station (2nd Street to north city limits)
12. New sidewalk/curb on the north side of 7th Street starting at a point about 100' east of Carmen Heights intersection to a point about 200' east of Carmen Heights intersection. Alder Street widened to 25' with 5' wide section of the road striped and marked for pedestrian use on the west side between 7th and Upland.

## Fully Funded Projects

### Newberg-Dundee Bypass

Phase 1 of the Newberg-Dundee Bypass is fully funded and in the final stages of design. This project includes the bypass itself from just south of Niederberger-Parks Road in Dundee to NE Wilsonville Rd in Newberg, a new road between Parks Road and Fulquartz Landing Road, and realignment of SE 8<sup>th</sup> Street, including the 8<sup>th</sup> Street overpass over the bypass.

### Dundee Downtown Improvements

The City of Dundee received an ODOT Transportation Enhancement grant to fund streetscape improvements on Highway 99W through downtown Dundee. The project will include improvements to sidewalks and lighting in several locations along Highway 99W between Niederberger-Parks Road and SW 1<sup>st</sup> Street. This project is fully funded, but still in the early stages of design, so exact locations and limits of the improvements have are not known. ODOT is also investigating installing one or more pedestrian crossing improvements between Niederberger-Parks Road and 1<sup>st</sup> Avenue.

## Goals, Evaluation Criteria and Scoring Parameters

Measure of Effectiveness	Evaluation Score	
<b>Goal 1: System Capacity and Mobility</b> Provide and maintain a transportation system that serves the travel needs of all Dundee residents, businesses, and visitors, and minimizes the adverse impact of through travelers on Dundee		
<b>System Connectivity</b> Connection enhances system efficiency	+2	Improves system efficiency
	+1	Improves efficiency in a localized area, but has no impact on efficiency of the system
	0	No change
	-1	Improves efficiency of a localized area, but may detract from the efficiency of another location
	-2	Negative impact on system efficiency
<b>Roadway Operations</b> Optimize operations of the roadway system	+2	Significantly optimizes roadway operations
	+1	Optimizes roadway operations
	0	No change
	-1	Reduces roadway operations
	-2	Significantly reduces roadway operations
<b>Goal 2: Livability</b> Provide and maintain a transportation system that fosters a pleasant, small city and preserves and enhances existing neighborhoods and businesses.		
<b>Street Aesthetics</b> Makes the transportation system more visually appealing	+2	Significantly improves street aesthetics
	+1	Improves street aesthetics
	0	No change
	-1	Detracts from street aesthetics
	-2	Significantly detracts from street aesthetics
<b>City Character</b> A transportation system that reflects the city's unique character	+2	Significantly adds to unique city character
	+1	Adds to unique city character
	0	Does not add or detract from unique city character
	-1	Detracts from unique city character
	-2	Significantly detracts from unique city character
<b>Street Classification</b> Provide street classifications that are consistent with residents' travel needs	+2	Provides street classification improvements that improve transportation conditions city wide
	+1	Provides street classification improvements that improve a localized area
	0	No change
	-1	Provides street classification improvements that improve a localized area, but may worsen transportation conditions at another location
	-2	Negative impact on transportation conditions

Measure of Effectiveness		Evaluation Score
<b>Goal 3: Coordination</b>		
Develop and maintain a transportation system that is consistent with and supports the goals, objectives, and visions of the Dundee community, participating and affected agencies, the county, and the state.		
<b>Regulatory Documents</b> Transportation system is compatible with regulatory documents	+2	Compatible with regulatory documents
	+1	Somewhat compatible with regulatory documents
	0	Not mentioned in regulatory documents
	-1	Compatible with regulatory documents in some respects, but incompatible in others
	-2	Not compatible with regulatory documents
<b>Support</b> Demonstrated public and/or decision-maker support	+2	Significant public and/or decision maker support
	+1	Some public and/or decision maker support
	0	Little public and/or decision maker support or opposition
	-1	Some public and/or decision maker opposition
	-2	Significant public and/or decision maker opposition
<b>Goal 4: Travel Options</b>		
Develop and maintain a transportation system that encourages, supports, and incorporates a variety of multi-modal travel options.		
<b>Pedestrian and Bicycle Access</b> Improves pedestrian and bicycle access to key destinations such as schools, parks, and recreation	+2	Significantly improves pedestrian or bicycle access to community destinations
	+1	Enhances pedestrian or bicycle access to community destinations
	0	No change
	-1	Reduces pedestrian or bicycle access to community destinations
	-2	Significantly reduces pedestrian or bicycle access to community destinations
<b>Pedestrian Comfort</b> Improves user experience and comfort to encourage higher numbers of walking trips (e.g., provide benches, planter strips, lighting, wayfinding)	+2	Significantly improves facility amenities
	+1	Improves facility amenities
	0	No change
	-1	Negatively impacts facility amenities
	-2	Significantly negatively impacts facility amenities
<b>Freight Access/Connectivity</b> Improve freight facilities and accommodates deliveries	+2	Significantly improves freight facilities
	+1	Improves freight facilities
	0	No change
	-1	Negatively impacts freight facilities
	-2	Significantly negatively impacts freight facilities
<b>Alternative Modes</b> Increase alternatives to single-occupant travel	+2	Serves more than two travel modes
	+1	Serves more than one travel mode
	0	Serves single travel mode
	-1	Serves single travel mode, but has a negative impact on another
	-2	Serves single travel mode, but has negative impact on more than one travel mode

Measure of Effectiveness		Evaluation Score	
<b>Attractiveness</b> Increase attractiveness of walking and bicycling	+2	Significantly improve facility attractiveness	
	+1	Improve facility attractiveness	
	0	No change	
	-1	Reduce facility attractiveness	
	-2	Significantly reduce facility attractiveness	
<b>Goal 5: Accessibility</b> Provide and maintain a well-connected transportation system that serves the needs of all members of the community and ensures adequate and efficient accessibility for all acknowledges land uses, and available mode of travel.			
<b>Connectivity</b> Improve connections to recreational and other local destinations	+2	Significantly increase connections to key destinations	
	+1	Increase connections to key destinations	
	0	No change	
	-1	Decreases access to key destinations	
	-2	Significantly decreases connections to key destinations	
<b>Americans with Disabilities Act</b> Comply with ADA requirements	+2	Significantly improves access for people with disabilities	
	+1	Improves access for people with disabilities	
	0	No change	
	-1	Decreases access for people with disabilities	
	-2	Significantly decreases access for people with disabilities	
<b>Land Use</b> Improvements that are supportive of local land use policies	+2	Very supportive of local land use policies	
	+1	Somewhat supportive of local land use policies	
	0	Does not impact local land use policies	
	-1	Supportive of some land use policies and not supportive of other land use policies	
	-2	Not supportive of land use policies	
<b>Access</b> Maintains or improves access to properties	+2	Significantly increases access to properties	
	+1	Increases access to properties	
	0	No change	
	-1	Decreases access to properties	
	-2	Significantly decreases access to properties	
<b>Goal 6: Environment</b> Provide and maintain a transportation system that preserves, protects, and supports the social, natural, and cultural environment of the Dundee community.			
<b>Ecosystem</b> Protects environmentally sensitive areas	+2	Significantly enhances natural environment	
	+1	Enhances natural environment	
	0	No change	
	-1	Negatively impacts natural environment	
	-2	Negatively impacts the natural environment in significant ways	



Measure of Effectiveness	Evaluation Score	
<b>VMT</b> Reduces vehicle miles traveled	+2	Significantly reduces vehicle miles traveled
	+1	Reduces vehicle miles traveled
	0	No change
	-1	Increases vehicle miles traveled
	-2	Significantly increases vehicle miles traveled
<b>Historic Preservation</b> Minimizes impacts to historic structures	+2	Restores or rehabilitates historic structures
	+1	Helps preserve historic structures
	0	Has no impact on historic structures
	-1	Negatively impacts historic structures
	-2	Significantly impacts historic structures in a negative way
<b>Social Interaction</b> Promotes opportunities for positive social interaction	+2	Significantly promotes positive social interaction
	+1	Promotes positive social interaction
	0	No change
	-1	Discourages positive social interaction (or encourages negative social interaction)
	-2	Significantly discourages positive social interaction (or significantly encourages negative social interaction)
<b>Goal 7: Timely Provision and Funding of Transportation Facilities and Services</b> Develop reasonable and effective funding and financing strategies and priorities to ensure that the future transportation facilities and services called for in the TSP are provided to support community development and acceptable transportation operations and safety.		
<b>Funding Opportunities</b> Eligible for a variety of funding opportunities (federal, state, local, or private development)	+2	Eligible for complete funding opportunities
	+1	Eligible for partial funding opportunities
	0	Can be funded through city capital improvement program
	-1	Can be partially funded through city capital improvement program
	-2	Cannot be funded through city capital improvement program
<b>Transportation Needs</b> Addresses a transportation need or deficiency identified in the TSP	+2	Addresses several transportation needs or deficiencies in the TSP
	+1	Addresses one transportation need or deficiency in the TSP
	0	Does not address a transportation need or deficiency in the TSP
	-1	Addresses a transportation need or deficiency in the TSP while worsening another transportation need or deficiency
	-2	Worsens transportation needs or deficiencies in the TSP

Measure of Effectiveness		Evaluation Score
<b>Goal 8: Safety</b>		
Develop and maintain a transportation system that protects the health and safety of transportation system users		
<b>Safety</b> Improves intersection/bicycle/pedestrian/railroad crossing safety	+2	Improves safety for all road users
	+1	Improves safety for some road users
	0	No change
	-1	Improves safety for some road users, but reduces safety for other road users
	-2	Reduces safety for all road users
<b>Goal 9: Economic Development</b>		
Provide and maintain a transportation system that supports the economic vitality of the Dundee community		
<b>Minimize Negative Impacts</b> Minimize negative impacts on existing land uses	+2	Significantly minimizes negative impact on existing land uses
	+1	Minimizes negative impact on existing land uses
	0	Does not impact existing land uses
	-1	Increases negative impact on existing land uses
	-2	Significantly increases negative impact on existing land uses
<b>Attractiveness</b> Increase attractiveness to investment and development	+2	Significantly increases attractiveness to investment and development
	+1	Increases attractiveness to investment and development
	0	No change
	-1	Decreases attractiveness to investment and development
	-2	Significantly decreases attractiveness to investment and development
<b>On-Street Parking</b> Minimize impacts to on-street parking	+2	Significantly increases on street parking or improves operations and safety of on street parking
	+1	Increases on street parking or improves operations and safety of on street parking
	0	No change
	-1	Adversely impacts on-street parking
	-2	Significantly adversely impacts on-street parking
<b>Access</b> Provide access to commercial and "destination" (recreation, wineries, tourism, etc.) uses	+2	Significantly improves access to commercial and destination uses
	+1	Improves access to commercial and destination uses
	0	No change
	-1	Reduces access to commercial and destinations uses
	-2	Significantly reduces access to commercial and destination uses

Project #	Project Name	Project Description	Goal 1: System Capacity and Mobility	Goal 2: Livability	Goal 3: Coordination	Goal 4: Travel Options	Goal 5: Accessibility	Goal 6: Environment	Goal 7: Timely Provision and Funding of Transportation Facilities and	Goal 8: Safety	Goal 9: Economic Development	Total	Project Cost
D1	7th St Extension	7th St extension to Alder St	1	1	0.5	0	1	0	0.5	0	0.25	<b>4.25</b>	\$215,000.00
D2	New Street	New street from 3rd St to 5th St	1	0.67	0.5	0	0.5	0	0.5	0	0.25	<b>3.42</b>	\$620,000.00
D3	Maple St Extension	Maple St extension from 8th St to 7th St	1	1	0.5	0	0.75	0	0.5	0	0.25	<b>4</b>	\$770,000.00
D4	13th St	13th St - new street from Alder St to Hwy 99W	1	0.67	0.5	0	1	0	1	0	0.25	<b>4.42</b>	\$545,000.00
D5	Alder St Extension	Alder St extension to Hwy 99W	1	1	0.5	0.2	0.75	0	1	0	0.5	<b>4.95</b>	\$705,000.00
D6	Fox Farm Rd Realignment	Fox Farm Road Realignment	0.5	0.33	0.5	0	0.5	0	0.5	2	0.25	<b>4.58</b>	\$950,000.00
D7	Edwards Rd Extensions	Edwards Rd Extension to Dayton Ave	1	0.67	0.5	0.2	0.5	0	0.5	0	0.5	<b>3.87</b>	\$1,410,000.00
D8	Edwards Rd Reconstruction	Edwards Rd reconstruction between 2nd St and 5th St	0.5	1	1	0.2	0.5	0	0.5	0	0.5	<b>4.2</b>	\$1,320,000.00
D9	Alder St Reconstruction	Alder St reconstruction between 9th St and Upland Dr	0.5	1	1	0.2	0.5	0	0.5	0	0.5	<b>4.2</b>	\$2,590,000.00
D10	8th St Reconstruction	8th St reconstruction between railroad and Edwards Rd	0.5	1	1	0.2	0.25	0	0.5	0	0.5	<b>3.95</b>	\$1,485,000.00
D11	8th St Connection	8th Street connection to Riverside	1	1	0.5	0.2	0.75	0	0.5	0	1	<b>4.95</b>	\$4,205,000.00
D12	New Street	New street from 5th St to 7th St	1	1	0.5	0	0.25	0	0.5	0	0.25	<b>3.5</b>	\$1,830,000.00
D13	North South Parkway	North South Parkway	1	0.67	0.5	0.2	1	0	0.5	0	1	<b>4.87</b>	\$9,285,000.00
D14	Edwards St Improvement	Improvement of Edwards to collector standards (8th-Parks)	1	1	0.5	0.2	0.5	0	0.5	0	0.5	<b>4.2</b>	\$1,370,000.00
D15	Parks Improvement	Improvement of Parks to collector standards (99W to Edwards)	1	1	0.5	0.2	0.5	0	0.5	0	0.5	<b>4.2</b>	\$2,885,000.00
D16	New Street	5th St to 7th St Connection	1	1	0.5	0.2	0.25	0	0.5	0	0.25	<b>3.7</b>	\$535,000.00
D17	99W Accel Lane	99W Acceleration Lane from 5th to 3rd	0.5	0	0.5	0	0.25	0	0	0	0	<b>1.25</b>	\$515,000.00
D18	Maple St Reconstruction	Maple St Reconstruction between 11th and Parks	0.5	1	0.5	0.2	0.5	0	0.5	0	0.5	<b>3.7</b>	\$820,000.00

Project #	Project Name	Project Description	Goal 1: System Capacity and Mobility	Goal 2: Livability	Goal 3: Coordination	Goal 4: Travel Options	Goal 5: Accessibility	Goal 6: Environment of Transportation Facilities and Services	Goal 8: Safety	Goal 9: Economic Development	Total	Project Cost	
W1	SW 1st St Sidewalks	1st St - sidewalks between Hwy 99W and lone St	0	0.67	1.5	1.2	0.75	0	1.5	1	0.5	7.12	\$20,000
W2	SW 1st St Sidewalks	1st St Sidewalk Infill	0	0.67	1.5	1.2	0.75	0	1.5	1	0.5	7.12	\$155,000
W3	SW 5th St Sidewalks	5th St - sidewalks on north side along park frontage to Dogwood Dr and infill on S side	0	0.67	1.5	1.4	1	0.25	1	1	0.25	7.07	\$470,000
W4	SW Dogwood St Sidewalks	Dogwood Dr - sidewalk infill	0	0.67	1.5	1.2	1	0	1.5	1	0.25	7.12	\$865,000
W5	SW Upland Dr Sidewalks	Upland Dr Sidewalk infill	0	0.67	1.5	1	1	0	1	1	0.25	6.42	\$120,000
W6	SW 9th St Sidewalks	9th St - sidewalks on both sides	0	0.67	1.5	1.4	1.25	0.25	1	1	0.25	7.32	\$1,310,000
W7	SW Alder St Sidewalks	Alder St - sidewalks on both sides Upland to past 11th (cost is between 9th and 11th - Upland to 9th completed as part of D9)	0	0.67	1.5	1.4	1.25	0.25	1	1	0.25	7.32	\$425,000
W8	SE Edwards Dr Sidewalks	Edwards Dr Sidewalks on both sides from 6th to 2nd	0	0.67	1.5	1.4	1.25	0.25	1	1	0.25	7.32	Part of D8
W9	SE 5th St Sidewalks	SE 5th St Sidewalk infill	0	0.67	1.5	1.2	0.75	0	1	1	0.25	6.37	\$75,000
W10	SE Edwards Dr Sidewalks	Edwards Dr Infill Sidewalks from 8th to Parks	0	0.67	1.5	1.4	1.25	0.25	1	1	0.25	7.32	Part of D14
W11	SE 10th St Sidewalks	10th St - Sidewalks on north side from Hwy 99W to Cedar St and near Edward St, all along south side	0	0.67	1.5	1.4	1.25	0.25	1	1	0.25	7.32	\$840,000
W12	SE Parks Rd Sidewalks	Parks Rd - sidewalks on both sides between Hwy 99W and Edwards Rd	0	0.67	1.5	1.4	1.5	0.25	1	1	0.25	7.57	Part of D15
W13	SW Niederberger Rd Sidewalks	Niederberger Rd Sidewalks	0	0.67	1.5	1.4	1.5	0.25	1	1	0.25	7.57	\$275,000

Project #	Project Location	Project Description	Goal 1: System Capacity and Mobility	Goal 2: Livability	Goal 3: Coordination	Goal 4: Travel Options	Goal 5: Accessibility	Goal 6: Environment	Goal 7: Timely Provision and Funding of Transportation Facilities and Services	Goal 8: Safety	Goal 9: Economic Development	Total	Project Cost
B1	5th St	Bike lanes from Alder to 99W	1	0.33	1	1.2	0.75	0.25	0.5	1	0	6.03	\$10,000
B2	Edwards Rd	Bike lanes south of 5th St	1	0.33	1	1.2	0.75	0.25	0.5	1	0	6.03	\$5,000
B3	9th/Worden Hill Road	9th/Worden Hill Road on-street trail	1	0.33	1	1.4	0.75	0.25	0.5	1	0	6.23	\$1,745,000
B4	9th/Worden Hill Road	9th/Worden Hill Road bike lanes (if road widened to collector standards)	1	0.33	1	1.2	0.75	0.25	0.5	1	0	6.03	\$20,000
B5	5th St	5th Street bike lanes (east of 99W)	1	0.33	1	1.2	0.75	0.25	0.5	1	0	6.03	\$5,000
B6	5th St	5th Street shared roadway (east of 99W)	0.5	0	1	0.8	0.75	0.25	0.5	1	0.25	5.05	\$5,000
B7	Parks Dr	Bike Lanes on Parks Dr	1	0.33	1	1.2	0.75	0.25	0.5	1	0	6.03	\$5,000
B8	10th St	10th St shared roadway	0.5	0	1	0.8	0.75	0.25	0.5	1	0.25	5.05	\$5,000
B9	Alder Street	Alder Street bike lanes	1	0.33	1	1.2	0.75	0.25	0.5	1	0	6.03	\$15,000
B10	Alder Street	Alder Street shared roadway	0.5	0	1	0.8	0.75	0.25	0.5	1	0.25	5.05	\$15,000
B11	1st Street	1st Street shared roadway from Highway	0.5	0	1	0.8	0.75	0.25	0.5	1	0.25	5.05	\$5,000
B12	8th Street	8th Street bike lanes (Riverside)	1	0.33	1	1.2	0.75	0.25	0.5	1	0	6.03	\$10,000
B13	7th Street	7th Street shared roadway	0.5	0	1	0.8	0.75	0.25	0.5	1	0.25	5.05	\$5,000
B14	Locust Street	Locust Street shared roadway	0.5	0	1	0.8	0.75	0.25	0.5	1	0.25	5.05	\$5,000
B15	11th Street	11th Street shared roadway (west of 99W)	0.5	0	1	0.8	0.75	0.25	0.5	1	0.25	5.05	\$5,000
B16	Redhills Drive	Redhills Drive shared roadway	0.5	0	1	0.6	0.75	0	0.5	1	0.25	4.60	\$10,000
B17	Dogwood Drive	Dogwood Drive shared roadway	0.5	0	1	0.6	0.75	0	0.5	1	0.25	4.60	\$5,000
B18	Edwards Drive	Edwards Drive shared roadway	0.5	0	1	0.8	0.75	0.25	0.5	1	0.25	5.05	\$5,000
B19	1st Street	1st Street shared roadway from Brier Pl to Walnut St	0.5	0	1	0.8	0.75	0	0.5	1	0.25	4.80	\$5,000
B20	Brier Place	Brier Place shared roadway	0.5	0	1	0.6	0.75	0	0.5	1	0.25	4.60	\$5,000
B21	3rd Street	3rd Street shared roadway	0.5	0	1	0.8	0.75	0	0.5	1	0.25	4.80	\$5,000
B22	6th Street	6th Street shared roadway	0.5	0	1	0.8	0.75	0.25	0.5	1	0.25	5.05	\$5,000

Project #	Project Location	Project Description	Goal 1: System Capacity and Mobility	Goal 2: Livability	Goal 3: Coordination	Goal 4: Travel Options	Goal 5: Accessibility	Goal 6: Environment	Goal 7: Timely Provision and Funding of Transportation Facilities and Services	Goal 8: Safety	Goal 9: Economic Development	Total	Project Cost
S1	6th St	6th Street trail extension to Riverside	0.5	0.67	1	1.6	1.25	0.25	0.5	2	0.75	8.52	\$575,000
S2	Dayton Ave - Edwards Dr	Dayton Avenue-Edwards Drive connection	0.5	0.67	1	1.6	1	0.25	0.5	2	0.5	8.02	\$275,000
S3	Viewmont Trail	Viewmont trail/linear park	0.5	0.67	1	1.6	1	0.25	0.5	2	0.5	8.02	\$1,315,000
S4	8th St	8th Street (west) vacation, conversion to off-street path	0.5	0.67	1	1.6	1.25	0.25	0.5	2	0.75	8.52	\$495,000
S5	13th St	13th Street (west) vacation, conversion to of-street path	0.5	0.67	1	1.6	1.25	0.25	0.5	2	0.75	8.52	\$95,000
S6	Viewmont to Fox Farm Rd	Trail connection between Viewmont and Fox Farm Road	0.5	0.67	1	1.6	1	0.25	0.5	2	0.5	8.02	\$350,000
S7	10th St at Bypass	Bike/ped undercrossing of Bypass at 10th Street	0.5	0.67	1	1.6	1.25	0.25	0.5	2	0.75	8.52	\$530,000
S8	1st St Connection	1st St SUP Connection	0.5	0.67	1	1.6	1.25	0.25	0.5	2	0.75	8.52	\$220,000
S9	SUP Connection to Subdivision	SUP Connection to Subdivision	0.5	0.67	1	1.6	1.5	0.25	0.5	2	0.75	8.77	\$445,000
S10	3rd St Connection	3rd St Connection to Upland	0.5	0.67	1	1.6	1.5	0.25	0.5	2	0.75	8.77	\$155,000
S11	7th to 5th Connection	5th to 7th St connection to school	0.5	0.67	1	1.6	1.25	0.25	0.5	2	0.75	8.52	\$310,000
S12	Viewcrest Connection	Viewcrest to Parking Lot Connection	0.5	0.67	1	1.6	1.25	0.25	0.5	2	0.75	8.52	\$65,000
S13	11th St Connection	11th St SUP Connection to Fulquatz	0.5	0.67	1	1.6	1.25	0.5	0.5	2	0.75	8.77	\$475,000
S14	T Connection	T Connection from Walnut to Viewmont and Red Hills	0.5	0.67	1	1.6	1.5	0.25	0.5	2	0.75	8.77	\$660,000

Project #	Intersection	Project Description	Goal 1: System Capacity and Mobility	Goal 2: Livability	Goal 3: Coordination	Goal 4: Travel Options	Goal 5: Accessibility	Goal 6: Environment	Goal 7: Timely Provision and Funding of Transportation Facilities and Services	Goal 8: Safety	Goal 9: Economic Development	Total	Project Cost
I1	Fox Farm-Dayton Road/Hwy 99W	Fox Farm-Dayton Road/Hwy 99W Traffic Signal	1	0	0.5	0	0.25	0	0.5	2	0.5	4.75	\$250,000
I5	5 <sup>th</sup> St/Hwy 99W	5 <sup>th</sup> Street phasing/signal upgrade (improve side street service)	1	0	0.5	0	0.5	0	0.5	0	1	3.5	\$50,000
I6	5 <sup>th</sup> St/Hwy 99W	Westbound right turn lane (5th/99W)	1.5	0	0.5	0	0.25	0	0.5	0	-0.3	2.5	\$565,000
R1	Parks Rd	Parks Rd RR Crossing Gates	0	0	1.5	0	0	0	0.5	2	0	4	\$300,000
R2	5 <sup>th</sup> St	5 <sup>th</sup> St RR Crossing Gates	0	0	1.5	0	0	0	0.5	2	0	4	\$300,000
C1	5 <sup>th</sup> St	5 <sup>th</sup> St - midblock crosswalk to connect post office with school and park	0.5	1	1	1.2	1.25	0	0.5	1	0.5	6.95	\$1,000
C2	Hwy 99W/1 <sup>st</sup> St	Crossing enhancements and RRFB	Part of TE Grant Project										
C3	Hwy 99W/13 <sup>th</sup> St	Crossing enhancements and RRFB											
C4	Hwy 99W/7 <sup>th</sup> St	Striped Crosswalk	0.5	1	1	1.2	1.25	0	0.5	1	0.5	6.95	\$1,000
C5	Hwy 99W/9 <sup>th</sup> St	Striped Crosswalk	0.5	1	1	1.2	1.25	0	0.5	1	0.5	6.95	\$1,000
C6	Hwy 99W/11 <sup>th</sup> St	Striped Crosswalk	0.5	1	1	1.2	1.25	0	0.5	1	0.5	6.95	\$1,000



Project #	Project Location	Project Description	Goal 1: System Capacity and Mobility	Goal 2: Livability	Goal 3: Coordination	Goal 4: Travel Options	Goal 5: Accessibility	Goal 6: Environment	Goal 7: Timely Provision and Funding of Transportation Facilities and Services	Goal 8: Safety	Goal 9: Economic Development	Total	Project Cost
P1	8th St	8th Street (west) parking capacity	0	0	0.5	0	0.5	0	0.5	0	1	2.5	\$750,000
P2	10th St	10th Street Parking Capacity	0	0	0.5	0	0.5	0	0.5	0	0	2.5	\$390,000

Project #	Project Location	Project Description	Goal 1: System Capacity and Mobility	Goal 2: Livability	Goal 3: Coordination	Goal 4: Travel Options	Goal 5: Accessibility	Goal 6: Environment	Goal 7: Timely Provision and Funding of Transportation Facilities and Services	Goal 8: Safety	Goal 9: Economic Development	Total
T1	Hwy 99W	Park and ride lots on Hwy 99W and moderate level of express bus service (30-minute peak, 60-minute off-peak)	0	0	0.5	0.6	0.25	0.5	0.5	0	0.25	2.6
T2	Hwy 99W	Improve Hwy 99W to serve the express bus transit stops	1	0	0.5	0.6	0.25	0.5	0.5	0	0.25	3.6
T3	Hwy 99W	Concentrate park-and-ride lots to support express and local bus service	0	0	0.5	0.4	0.25	0.25	0.5	0	0.25	2.15
T4	City Wide	Use local buses to feed the inter-city express bus system	1	0	0.5	0.6	0.25	0.5	0.5	0	0.25	3.6
T5	McMinnville	Consider a commuter rail line from McMinnville to the Wilsonville/Beaverton commuter rail line.	0	0	0	0	0	0	0	0	0	0
T6	Riverside	Transit service to Riverside area	1	0	0.5	0.6	0.25	0.5	0.5	0	0.25	3.6
T7	City Wide	Transit loop service (using Alder, Edwards)	1	0	0.5	0.6	0.25	0.5	0.5	0	0.25	3.6
T8	Hwy 99W	Second pair of stops on 99W	0.5	0	0.5	0.6	0.25	0.5	0.5	0	0.25	3.1

# MEMORANDUM

**DATE:** 28 Apr 14  
**TO:** Dundee TSP Project Management Team  
**FROM:** Carl Springer  
**SUBJECT:** **Dundee TSP Update**  
Tech Memo 9: Stakeholder 2<sup>nd</sup> Interview Summary

P# 11086-003-005

---

DKS Associates conducted eight stakeholder interview sessions in February 2014 to gain feedback on transportation issues and potential solutions in Dundee. This memo summarizes the interview process and input provided during the interviews, including recommendations for potential projects.

## Interview process and participants

Participants were selected to complement the input that the Project Advisory Committee provides. The following stakeholders were interviewed:

1. Nancy Ponzi, Ponzi Winery
2. Don Clements, Chehalam Park and Recreation District
3. Don Sundeen, former Mayor
4. Bert Handifan, Dundee Volunteer Firefighter
5. Tom & Kay Edwards, Landowner; Larry Anderson, development representative
6. Mart Storm, local developer
7. Ken Johnston, 12 & Maple Wine Company
8. Joyce Colling, Dundee Womans Club
9. Stuart Lindquist, major property representative; Dale Bernards, development representative

Each interview lasted between 30 minutes and 1 hour. The purpose of the interviews was get the participants reactions to the Future Needs findings and the initial team suggestions to address those community needs.

## Interview Feedback

Themes and highlights from the interviews are summarized in the following sections by topic.

### Riverside District Area

Stakeholders acknowledged that the initial access plan for the Riverside District Area has changed significantly. The previous plans expected connections to the highway via 5<sup>th</sup> Street and 8<sup>th</sup> Street, and neither of these are favored at this point, given recent decisions by the City to locate the new fire station on 8<sup>th</sup> Street and the regulatory challenges with extending 5<sup>th</sup> Street outside the Urban Growth Boundary. Local property owners contend that these changes adversely impact the development potential for this area. They suggest that the 5<sup>th</sup>



Street connection should be examined further, and that the City should take the lead on solving the challenges necessary for making this extension happen.

Further comments about planned streets within the Riverside District included:

- The planned collector street on the riverside of the Bypass (Driving Project #25) is challenging to construct since it spans multiple property ownerships. This limits the possibility for one owner to advance a development application.
- The neighborhood streets in the District Area Plan are too wide (60 feet right-of-way); lesser options should be considered

Of the highway connection choices being considered through the TSP update, the best choice seems to be the 9<sup>th</sup> Street extension, since it is close to the previous 8<sup>th</sup> Street concept.

### Downtown Circulation Options

Stakeholders reviewed the initial downtown circulation options. The intent was to replace the previously planned 8<sup>th</sup> Street extension with a new primary connection to the highway in the downtown area that served the riverside area of the City. The designated primary street would be improved to match current City standards such as standard travel lanes, bike facilities and sidewalks. Options considered one of the following alignments: 9<sup>th</sup> Street, 10<sup>th</sup> Street, 11<sup>th</sup> Street or 12<sup>th</sup> Street. Stakeholder comments were as follows:

- 9<sup>th</sup> Street
  - The best choice is the 9<sup>th</sup> Street extension, since it is close to the previous 8<sup>th</sup> Street concept.
  - Likes 9<sup>th</sup> Street since it leads to Worden Hill Road and connections to wineries and trail areas.
  - Prefer 9<sup>th</sup> Street extension without the Linden Street extension as an element.
- 10<sup>th</sup> Street
  - The best choice is 10<sup>th</sup> Street, since it has an existing railroad crossing and most of the street is already built between the highway and Edwards Avenue. It would be the least cost option.
- 11<sup>th</sup> Street
  - This is a good choice because there is a connection west of the highway.
  - Beech Street has been vacated. A better route would be to continue to Cedar Street and not use the route via Elm Street.
- 12<sup>th</sup> Street
  - The existing railroad crossing is designated for private use only (note: this needs to be verified)
  - The 12<sup>th</sup> Street / Cedar intersection, as shown, it too close to Park Avenue
  - Cut-through traffic issues today for traffic avoiding the gravel section of Maple Street
- General
  - The need for a new traffic signal at any of the above is reduced because of the planned signal at the Bypass terminus ramp.
  - Proposed Linden Lane extension between 9<sup>th</sup> Street and 11<sup>th</sup> Street has a few issues
    - The Linden Lane extension is difficult to construct as shown. Perhaps an alley cross-section would fit better.

- Linden Lane extension would limit development options for affected property owners.
- Alder Street connection to Niederberger Road would provide suitable connectivity to Linden Lane
- Supports the concept of separating residential and industrial uses on either side of the swale; this would involve rezoning existing undeveloped industrial property
- Walking paths near 12<sup>th</sup> Street would benefit existing uses

## Funding

Stakeholders mentioned specific funding issues in Dundee and some ideas for improvement, including:

- Need another way to construct street upgrades beyond just charging the fronting property owners; some type of shared cost system to recognize the benefits provided to other users
- Perhaps consider a Local Improvement District or transportation System Development Charge
- Strategic transportation investments can stimulate new business investments

## Biking and Walking

Many stakeholders expressed support for improve bicycling and walking conditions in Newberg. Stakeholder suggestions for biking and walking projects are summarized as follows:

- Parks Avenue – should be improved to include bike facilities. Too narrow for bike lanes today.
- Higher quality pedestrian crossing facilities on highway located in the central part of town (7<sup>th</sup> Street) would be more effective than being located on the edge of town
- Filling in priority sidewalk gaps could be funded through Local Improvement District
- Proposed trails through private property (such as S11) limits development options
- Project S2 (Dayton Avenue extension – outside city limits) s crucial to the regional trail system
- Need to confirm the City’s policy about upgrading existing streets without sidewalks. Are improvements needed on both sides of the roadway?

## Connectivity Issues

Stakeholders mention these system connectivity issues:

- 7<sup>th</sup> Street connects from the highway to Alder Street. It should be extended to connect a few hundred feet to fill the gap and provide a 2<sup>nd</sup> direct route into the neighborhood
- Would like to see better transit service
- Maple Street extension (Project D3) is opposed by adjoining neighbors and not supported by the park district

## General Transportation Issues

Stakeholders mentioned these general transportation issues:

- Need 4-way stop controls at Alder Street and 9<sup>th</sup> Street and Alder Street at 11<sup>th</sup> Street

## Memorandum

Date: April 28, 2015

To: City of Dundee Transportation System Plan (TSP) Update Project Management Team and Project Advisory Committee and City of Dundee Planning Commission and City Council

From: Darci Rudzinski and Shayna Rehberg, Angelo Planning Group

cc: Carl Springer and Ray Delahanty, DKS

Re: Technical Memorandum #10 – Final Draft Implementing Ordinance Language (Task 6.1)

This memorandum presents draft proposed amendments to the City of Dundee Comprehensive Plan and Development Code, pursuant to Task 6.1. The amendments in this memorandum are the product of the following process to date:

1. Amendment concepts were proposed in a preliminary set of recommendations (see Draft Implementing Ordinances memorandum dated April 18, 2014);
2. The amendment concepts were developed into policy and code amendment language and presented as a first draft to the Project Management Team (PMT) (Draft Implementing Ordinances memorandum dated July 15, 2014);
3. These draft proposed amendments were revised based on PMT comments and presented as the Revised Draft Implementing Ordinance Language memorandum dated January 21, 2015;
4. The January 21, 2015 memorandum was provided to the Project Advisory Committee, Planning Commission, and City Council and reviewed in part at a meeting and a work session on February 11 and February 18, 2015; and
5. This Final Draft Implementing Ordinance Language memorandum was prepared based on comments made at and following the February meetings.

Proposed policy and code amendments should be reviewed and considered for adoption in conjunction with the updated City of Dundee Transportation System Plan (TSP), as they include amendments that implement recommendations from the updated TSP, create consistency between the TSP and other local documents, and comply with State transportation planning regulations. Proposed Comprehensive Plan policy amendments (Table 1) and Development Code amendments (Table 2) will be revised based on recommendations and feedback from the PMT, Project Advisory Committee (PAC), community

members, Planning Commission, and City Council following an upcoming set of meetings and prior to public hearing proceedings and adoption.

## Proposed Policy Amendments

The City’s Comprehensive Plan (1977) includes a set of goals, objectives, and policies that direct development of the City’s transportation system (pp. 72-76).<sup>1</sup> Technical Memorandum #3 (Draft Goals, Objectives, and Evaluation Criteria) provided preliminary recommendations for updating the City’s adopted transportation system goals, objectives, and policies. Additional direction for policy areas to include or strengthen in the Comprehensive Plan has been provided by City Staff and the Policy Advisory Committee through the TSP development and update process. Table 1 includes exiting Comprehensive Plan language and proposed modifications (additions are underlined; deletions are ~~struck through~~), as well as an indication of why the changes are being proposed. Proposed modifications reflect:

- Text changes suggested for clarity with existing City practice and requirements.
- Direction and decisions generated from TSP update process.
- Updated Newberg-Dundee Bypass policies.
- Updated language that supports and is consistent with the adopted Riverside District Master Plan.
- New language that supports Downtown growth and development, such as planning for a transportation system that would support planned land uses/mixed land uses, a pedestrian-oriented streetscape, “green corridors” for pedestrians and bicyclists, etc.

**Table 1: Recommended Comprehensive Plan Policy Amendments**

Recommended Policy Amendments		Commentary
GOAL		
	To provide and encourage a safe, convenient, aesthetic and economical transportation system, addressing the needs of all citizens within the community.	
OBJECTIVES		
A.	<del>The development of</del> <u>Develop</u> a well-connected street network that is safe, accessible and efficient for motorists, pedestrians, bicyclists and the transportation	The proposed modification provides a consistent sentence

<sup>1</sup> Note that the Comprehensive Plan includes transportation policies adopted in 2003 and 2004 (pp. 74-76), but more recent adopted policy pertaining to the Newberg-Dundee Bypass (adopted in Ordinance 502-2011, Policies 7 and 10-14) was not incorporated into the Comprehensive Plan document.



Recommended Policy Amendments		Commentary
	disadvantaged.	structure.
B.	Preserve the aesthetic quality of the community.	
C.	<del>The construction of a</del> Provide safe, continuous and direct network of streets, accessways, and other improvements, including bikeways, sidewalks, and safe street crossings to promote safe and convenient bicycle and pedestrian circulation within Dundee.	The proposed modification provides a consistent sentence structure.
D.	<del>Develop policies for the location and improvement of arterials, collectors, local streets and sidewalks.</del>	This objective is a more specific directive than the others listed; suggested replacement language is found in Policy 1.
E-D.	Improve the transportation links <u>between the City and other destinations and employment centers within the region as well as other regions of the state, while encouraging alternative transportation modes for commuters.</u>	The proposed modification specifies that the policy improves transportation to and from Dundee.
POLICIES		
A. General Transportation Network		
1.	<del>The designated arterial and collector streets of the street network will be used to assist in prioritizing street development and maintenance.</del> <u>The City shall adopt and maintain transportation design and development regulations that address all elements of the city transportation system and that promote access to and use of a multi-modal transportation system.</u>	Because functional classification is not the only consideration when prioritizing street development and maintenance, this policy is recommended for removal. Proposed language addresses all transportation modes and the City's role in adopting and maintaining standards.
2.	<del>The City of Dundee shall protect the function of existing and planned roadways as identified in the Transportation System Plan (TSP) and will ensure that all development</del>	The first part of Policy 2 and Policy 3 are related; the language proposed show the consolidation of

Recommended Policy Amendments		Commentary
	<p><u>proposals, plan amendments, and zone changes are consistent with the adopted TSP.</u></p> <p><del>This policy recognizes the proposed new street locations are conceptual in nature and the actual dedication and installation of improvements shall comply with applicable regulations, including environmental provisions.</del></p>	<p>the two existing Policies. The second part of Policy 2 is proposed to be replaced with (new) Policy 3.</p>
3.	<p><del>All development proposals, plan amendments, or zone changes shall conform with the adopted Transportation System Plan. The location of proposed new major streets identified in the TSP is conceptual and actual street improvements and installation shall be based on detailed engineering specifications, design considerations, and assessment of local impacts.</del></p>	<p>It is proposed to consolidate existing language with Policy 2. New Policy 3 is intended to reflect the intent of eliminated section of (existing) Policy 2.</p>
4.	<p><del>The City of Dundee shall include a consideration of their impacts on existing or planned transportation facilities in all land use decisions, and shall require applicable developments (as defined in the Development Code) to prepare a transportation impact analysis.</del></p>	<p>Proposed additional language supports implementation of transportation impact analysis and mitigation requirements in the Development Code.</p>
5.	<p>Transportation facility siting and design shall be done in a manner that will minimize adverse effects on the existing land uses and natural features.</p>	
6.	<p><del>The City of Dundee shall protect the function of existing or planned roadways or roadway corridors through the application of appropriate land use regulations, exactions, voluntary dedication, or setbacks. require that proposed land developments mitigate their adverse transportation impacts and ensure that all new development contributes a fair and proportionate share toward on-site and off-site transportation system improvements.</del></p>	<p>Existing Policy 6 is similar to Policy 2. Proposed revisions are more specific to developers' role and are related to the traffic impact analysis requirements proposed for inclusion in the Development Code.</p>
7.	<p><u>The City supports minimizing direct access points on Highway 99W to improve mobility and safety through Dundee. New direct access to Highway 99W shall be granted only after consideration is given to Oregon</u></p>	<p>It is proposed that all references to "Oregon Department of Transportation" be</p>

Recommended Policy Amendments		Commentary
	<p>Department of Transportation (ODOT) approval <del>access management standards, land use and traffic patterns in the area of development, and not just at the specific site.</del> <u>Common driveway consolidation and other access management techniques may shall be encouraged or required to coordinate traffic and land use patterns and these shall be implemented wherever feasible.</u></p>	<p>changed to “ODOT.”          The proposed addition emphasizes the need to minimize conflicts on Highway 99W and ODOT’s authority to manage access on the highway.</p>
8.	<p>The City shall coordinate development and revisions of its <del>TSP transportation systems plan with the ODOT Oregon Department of Transportation and Yamhill County.</del> Improvements listed in ODOT's Statewide Transportation Improvement Program that affect Dundee shall be consistent with the City's <del>Transportation System Plan</del> <u>TSP and Comprehensive Plan.</u></p>	
9.	<p><del>Off-street parking shall be provided by all land uses to improve traffic flow, promote safety, and lessen sight obstruction along the streets. On- and off-street parking facilities are part of the transportation system, and will be managed and regulated to ensure sufficient parking is provided, maximize efficiency, minimize impacts to traffic in the right-of-way, and reduce environmental impacts.</del></p>	<p>Proposed language is more inclusive, addressing all types of parking.</p>
10.	<p>The City shall <del>develop a use its adopted Capital Improvement Program to identify and prioritize and schedule transportation projects based upon need as shown in the TSP.</del></p>	<p>Proposed amendments refine existing policy, meant to clarify how the City uses the CIP/TSP.</p>
11.	<p>All City streets shall operate at a Level of Service standard "D" or better during the 20 year planning period. When the LOS drops to "E," actions will be initiated to return the street to LOS “D”.</p>	
12.	<p>The City of Dundee shall <del>work coordinate with ODOT Oregon Department of Transportation on a continual basis to have a on the siting and installation of needed traffic signals, installed at the Parks Road/ along Highway 99W and 10th Street/Highway 99W intersections as soon as possible as</del></p>	<p>Updated policy relies on the TSP analysis to support the installation of signals.</p>

Recommended Policy Amendments		Commentary
	<u>identified in the TSP.</u>	
13.	<p><del>Through the refinement plan process, the City of Dundee will investigate the potential of developing a unique streetscape plan for the community's downtown, including the potential for establishing a Special Transportation Area consistent with ODOT regulations.</del></p> <p><u>The City will continue to partner with ODOT to design and implement streetscape improvements on Highway 99W through downtown, including directing funding for the 99W 1st Street to Parks Drive Streetscape Project for needed sidewalk, lighting, and pedestrian crossing improvements.</u></p>	<p>This policy is recommended for elimination. An STA designation is likely no longer necessary, given the changing nature of 99W due to the Bypass and ODOT TE grant for streetscape improvements. Proposed new policy language reflects the partnership between ODOT and the City to implement streetscape design.</p>
14.	<p><u>Maintain access to the Willamette River so that the river may be used for transportation purposes in the future.</u></p> <p><u>Continue to explore ways to improve access to Willamette River for public docking and boat launch purposes.</u></p>	<p>Proposed new policy emphasizes the importance of river access for not only recreational purposes, but also as a means of transportation.</p>
15.	<p><u>The City will encourage and support Yamhill County to develop and construct a connection between Dundee Landing Road and Edwards Road at 5<sup>th</sup> Street to improve connectivity east of the Bypass to the river.</u></p>	<p>This proposed new policy emphasizes the Riverside master plans preferred connection to 5<sup>th</sup> street.</p>
16.	<p><u>The City will encourage and support Yamhill County to develop and construct a connection between Edwards Road and Dayton Avenue to improve connectivity on the east side of the railroad.</u></p>	<p>This proposed new policy emphasizes the need for an additional connection on the east side of the railroad due to reduction in railroad crossings.</p>
17.	<p><u>The City shall determine appropriate improvements for 7<sup>th</sup> Street directly west of Alder that improve pedestrian and bicycle access and provide emergency access without requiring a full street improvement to be constructed.</u></p>	<p>In removing a street improvement project for this road segment from the Draft TSP, the</p>

Recommended Policy Amendments		Commentary
		Planning Commission and City Council requested than an alternate improvement be made. This proposed policy will act as a placeholder until the alternate improvement is determined and added to the City's capital improvement program.
18.	<u>Gated and restricted-access residential subdivisions shall be discouraged in Dundee.</u>	This policy is proposed particularly to improve emergency access throughout the city.
<b>B. Newberg-Dundee Bypass</b>		
1.	The City shall coordinate with the <del>ODOT Oregon Department of Transportation</del> , Yamhill County and other affected agencies regarding the <del>location and construction</del> <u>development</u> of the Newberg-Dundee Bypass.	Proposed amendment is inclusive of Phase I construction and future phase planning.
2.	The City <del>supports the construction of Phase I of the Bypass and shall encourage the selection of a bypass alternative design and construction of future phases that</del> <u>ensures that sufficient traffic is diverted from Highway 99W through Dundee to allow the remaining traffic to be served by two travel lanes within the Transportation Plan's TSP's planning horizon.</u>	
3.	The City <del>shall encourage the new by-pass</del> <u>supports a Bypass design to that provides adequate public access - including pedestrian, bicycle, vehicle and recreational - to the Willamette River.</u>	
4.	The City shall encourage the new bypass design to incorporate adequate buffering and physical separation between the new highway, and, public access to the Willamette River and existing residential neighborhoods.	

Recommended Policy Amendments		Commentary
5.	<del>Improvements for street connectivity within the City, including alternative linkages to adjacent communities, shall not occur until such time the bypass is in operation.</del>	This policy is no longer necessary. The updated TSP addresses connectivity within the City, including proposed improvement projects, assuming Phase 1 of the Bypass.
6.	<del>The land use decisions regarding the location of the proposed Newberg-Dundee Bypass shall be made through a subsequent amendment to the Dundee TSP. As part of this process, the City recognizes Newberg and Yamhill County will need to amend their TSPs to authorize a bypass corridor, and, Yamhill County must take an exception to Statewide Planning Goal 12 to authorize a new transportation facility in rural lands.</del>	This policy direction will be fulfilled locally through the updated TSP.
7.5.	<del>The City actively supports the development of the Newberg-Dundee Bypass in the southern location corridor described as Alternative 3J (Modified) in the Tier 1 Location Environmental Impact Statement. The City prefers a below-grade roadway, however the City recognizes that ODOT has selected an at-grade roadway with 6-8 foot berms as the preferred alternative in the Tier 2 Draft Environmental Impact Statement (DEIS) process. The City actively supports the development of the Bypass in the southern location corridor described in the Tier 2 Environmental Impact Statement (EIS) process.</del>	This policy, most recently revised in 2011 by Ordinance 502-2011 to reflect the Newberg-Dundee Bypass Tier 2 Alignment, has been updated to be consistent with Tier 2 DEIS. <i>(Note: This language is also Goal 4, Policy h in the Newberg Comprehensive Plan.)</i>
<del>8.6.</del>	<del>The City affirms its support for a Bypass location and design that recognizes existing Comprehensive Plan policies, including Recreation and Willamette River Greenway policies, and which includes providing public access to the Willamette River and the City's waterfront for park and recreational development.</del>	
9.7.	The City recognizes the designation of the Bypass as a statewide expressway and freight route as defined in the Oregon Highway Plan. The City expects the Bypass and interchanges will be fully access controlled and no direct	

Recommended Policy Amendments		Commentary
	access will be allowed from private properties on the Bypass or within the Interchange Management Areas as defined by the OHP.	
10. 8.	For purposes of City compliance with the Transportation Planning Rule (OAR 660-012-0060), the City will not consider or rely on <u>future phases of the Bypass (including the proposed East Dundee Interchange) improvement that is reasonably likely to be constructed during the 20-year planning horizon</u> until the OTP includes all or a specific phase of the Bypass in the construction section of the Statewide Transportation Improvement Program (STIP) or until ODOT agrees, in writing that all or a portion of the bypass may be considered a planned improvement. During the period before <u>the future phases of the Bypass</u> can be considered a planned improvement, the City of Dundee will work with ODOT to <u>pursue mutually agreed upon implement alternative mobility standards for Highway 99W through Dundee</u> to comply with OAR 660-012-0060.	The TSP update's future needs analysis assumes the construction of Phase 1 of the Bypass. Proposed language is directed towards future phases.
11. 9.	<u>The City shall maintain and update, as necessary, zoning and development regulations to manage land uses and access in the vicinity of the Bypass interchange that are consistent with the primary function of the bypass to serve through traffic and that are consistent with the Oregon Highway Plan. The City in conjunction with ODOT shall maintain intersection/interchange management plans and, if proposed in the future, corridor plans to establish a framework for managing access and land uses along Bypass, as necessary to implement the TSP.</u>  An Interchange Area Management Plan (IAMP) will be developed to protect the function and capacity of the East Dundee Interchange for at least a 20 to 25-year period. The IAMP must be adopted by the Oregon Transportation Commission (OTC) before construction of the interchange, consistent with the requirements of the 1999 Oregon Highway Plan and OAR 734-051-0155(7).	Proposed policy language reflects how the City proposes to participate in future IAMP/corridor planning. <i>(Note: Proposed language is similar to Newberg's Goal 2, Policy b: "The City shall adopt zoning and development overlay regulations to manage land uses and access in the vicinity of Newberg-Dundee Bypass interchanges that are consistent with the primary function of the bypass to serve through traffic and that are consistent with the Oregon Highway Plan. Highway oriented development and retail commercial shall be precluded at proposed access points.")</i>



Recommended Policy Amendments		Commentary
<del>12.</del> <u>10.</u>	<del>Figure 6-1 of the Dundee TSP identifies three potential collector road crossings of the Bypass for illustrative purposes only. The City recognizes that one of the crossings will be constructed as part of the Bypass project to maintain connectivity between downtown Dundee and the Riverfront. The Tier 2 DEIS, Preferred Alternative, identifies an overcrossing in the vicinity of 8th Street. The City is in the process of master planning the undeveloped area between Dundee and the Willamette River. At a future date, Figure 6-1 of the Dundee shall be amended to reflect either the Tier 2 DEIS Preferred Alternative for the overcrossing or the location for the overcrossing identified in the adopted Riverfront master plan. ODOT will continue to coordinate with the City on location of the overcrossing and is flexible on the ultimate location with the UGB if it could serve all properties ownerships between the Bypass and the Willamette River.</del>	The location and design of the Bypass in Dundee has been determined, as have two direct routes under construction. Therefore, this policy is no longer necessary.
<del>13.</del> <u>11.</u>	The City recognizes that the Oregon Highway Plan seeks to avoid UGB expansions along Statewide Highways and around interchanges unless ODOT and affected cities and counties agree to an Interchange Area Management Plan to protect interchange operation or access management for segments along the highways. (OHP Action 1B.48).	
C. Pedestrian and Bicycle Facilities		
1.	<del>In areas of new development the City of Dundee shall investigate the existing and future opportunities for bicycle and pedestrian accessways. Existing accessways such as user trails established by school children distinguish areas of need and should be incorporated into the transportation system. The City will work to improve and expand pedestrian and bicycle facilities throughout the community, including establishing a connected trail system accessing the Willamette River, with a focus on improved connectivity within the city and to regional bicycle routes and trails systems.</del>	Existing policy has largely been accomplished through the Riverside District Master Plan and this TSP update. Proposed language provides ongoing direction. Policy 6 from the Master Plan includes the following:  “A connected trail system shall be required to accommodate the

Recommended Policy Amendments		Commentary
		Willamette River Trail, the Chehalem Heritage Trail, and connecting local trails within the Riverside District that link to the larger community trail system.”
2.	<del>Bike lanes and/or sidewalks shall be included on all new arterials and collectors within the Urban Growth Boundary, as referenced by the Transportation System Plan. New and existing urban collector streets will be required to accommodate bicycle facilities and sidewalks on both sides of the street, with deferrals of sidewalk improvements allowed pursuant to conditions established in the development code. Modified sidewalk design is permitted on streets constrained by topography, environmental conditions, or existing development, consistent with the design guidelines in the TSP.</del>	Proposed modifications are based on TSP update direction. Reference to roadway standards are consistent with the Draft TSP and proposed code amendments.  <i>Note: In the TSP, bicycle facilities include separated facilities outside the roadway (shared-use path), dedicated in-road facilities (bike lanes), and shared lane facilities.</i>
3.	<del>Sidewalks shall be included on all new streets within the Urban Growth Boundary as referenced in the TSP, except in the case of non-collector streets where sidewalks can be accommodated only on one side of the street due to topographic, environmental, or other development constraints.</del>	This policy, and Policy 2 above, provide consistency with standards and figures/maps in the updated TSP and with direction from the PMT, PC, and CC.
4.	<del>Where feasible, bikeways and pedestrian accessways shall connect to local and regional travel routes.</del>	Existing Policy 4 is proposed to be included in modified Policy 1.
54.	Bikeways and pedestrian accessways shall be designed and constructed to minimize potential conflicts between transportation modes. Design and construction of such facilities shall follow the guidelines established by the Oregon Bicycle and Pedestrian Plan.	
65.	Maintenance and repair of existing bikeways and pedestrian accessways (including sidewalks) shall be given equal	

Recommended Policy Amendments		Commentary
	consideration to the maintenance and repair of motor vehicle facilities.	
76.	To achieve a safe, continuous and direct network of sidewalks and bikeways, <del>it is one of the City's priorities is to construct, or to require as part of development,</del> these facilities on the streets depicted on the Pedestrian/Bicycle Plan Map <del>as incorporated within in the Transportation System Plan</del> TSP.	Modifications are proposed for internal consistency.
87.	The City of Dundee shall consider the potential to establish or maintain accessways, paths, or trails prior to the vacation of any public easement or right-of-way.	
98.	Where possible, financially feasible, <u>or otherwise required by law,</u> the City will upgrade <u>or require the upgrade of</u> existing substandard sidewalks.	This policy should be reviewed to reflect the City's priorities and commitment to sidewalk infill. Policy language should reflect TSP direction and be consistent with updated code requirements.
9.	<u>Require new development to include sufficient and convenient bicycle parking, and encourage improvements to bicycle parking facilities at key destinations along Highway 99W in downtown Dundee. Allow a range of bicycle parking solutions to address the specific needs of different users.</u>	Proposed new policy is consistent with identified biking needs (see Future Needs Analysis, Memorandum #6) and supports recommended Development Code requirements.
<b>D. Public Transportation</b>		
1.	The City shall <del>encourage the creation of a customer-based and oriented regionally coordinated</del> support a regional public transit system that is efficient, effective, and founded on present and future needs.	
2.	<del>The City shall P</del> romote regional planning of public transportation services and encourage the use of innovative	

Recommended Policy Amendments		Commentary
	technology to maximize efficiency of operation, planning and administration of public transportation.	
3.	<del>The City encourages the development of a daily transit shuttle service to the major activity centers in Newberg and McMinnville as well as the Portland and Salem metropolitan areas.</del> <u>will work with the local transit provider to improve daily service to Dundee and the communities of Tigard and McMinnville.</u>	Policy is proposed to be updated to reflect existing Yamhill County Transit Area service and future review and coordination of and updates to service.
4.	<u>The City will explore the feasibility of enhancing transit within the city, including using local buses to feed the inter-city express bus system, establishing a transit loop service (using Alder Street and Edwards Street), and providing future service to the Riverside District.</u>	Proposed new policy reflects transit projects and options explored as part of the TSP update process.
5.	<u>The City supports the concept of commuter rail service serving the West Valley and providing connections with the Portland metropolitan area. If passenger rail service does become a reality, the City will encourage the development of a passenger rail depot in Dundee, including necessary Development Code revisions to permit construction.</u>	This is existing policy, moved from Rail section.
6.	<u>The City will work with transit service providers and developers to provide access to public transportation stops and to provide public transportation amenities (e.g., easements or dedications for shelters, lighting).</u>	Policy supports other City policies to expand and improve intercity and intracity transit service. It is also consistent with transit requirements in TPR Section -0045(4).
<b>E. Rail and Freight and Pipeline Transportation</b>		
1.	The City shall coordinate land use planning adjacent to the Willamette and Pacific Railroad facilities in order to promote industrial development with rail access.	
2.	The City will work with the local rail operator, <del>ODOT</del> <u>the Oregon Department of Transportation</u> , and other affected agencies or businesses to improve the at-grade railroad	

Recommended Policy Amendments		Commentary
	crossings within the community.	
3.	<del>The City supports the concept of commuter rail service serving the West Valley and providing connections with the Portland metropolitan area. If passenger rail service does become a reality, the City will encourage the development of a passenger rail depot in Dundee, including necessary Development Ordinance revisions to permit construction.</del>	It is recommended to move this policy to the Public Transportation section.
4. 3.	The City supports activities that maintain adequate pipeline operations such as natural gas service into, within and through Dundee.	

## Proposed Development Code Amendments

Dundee Municipal Code (DMC) Division 17 is the City’s Development Code. The Development Code implements the goals, objectives, and policies of the Comprehensive Plan. Amendments to the Development Code are recommended to address the following objectives:

- Create consistency between the updated TSP, the Development Code, and the Public Works and Engineering Design Standards;
- Strengthen compliance of the Development Code with the Transportation Planning Rule (TPR); and
- Progress toward specific City objectives, such as providing a complete pedestrian system and filling in sidewalk gaps on arterial and collector streets.

Table 2 presents recommended Development Code amendments. Specific code language that is proposed to be added is underlined and language that is proposed to be deleted is ~~struck through~~. In some instances there will be new text shown in [brackets]; this denotes where choices regarding thresholds need to be considered. Explanations for each set of amendments are provided in the right-hand column of Table 2.

Table 3 addresses recommended Public Works Design Standards amendments. These do not necessarily present adoption-ready language as is done for the Development Code amendments. Rather, the nature of amendments that are needed or may be needed is discussed, in particular, pending review of the Draft TSP document.

As stated at the beginning of this memorandum, these amendments will be reviewed with the PMT before they are presented to the PAC. Revised amendments will be available for PAC review before final draft amendments are prepared for public hearing.

Notes: Recommendations for Development Code amendments are generally presented in sequential order of the Development Code sections. When a change is recommended that may apply to more than one code section, the change is presented in order of the earliest code section.

In addition to the amendments proposed in this memorandum, the entire Development Code should be checked to amend all references to the updated TSP, as needed.

**Table 2: Recommended Development Code Amendments**

	Recommended Development Code Amendments	Commentary
1.	<p><b>CHAPTER 17.202 ZONING REGULATIONS</b></p> <p>DMC Table 17.202.020 (Zoning Use Table)</p> <p><i>Amendments proposed to this table are presented in Attachment A.</i></p>	<p>TPR Subsection -0045(1)(a) requires local development codes to permit transportation facilities, services, and improvements that are determined to not have a significant impact on land use, so that they are not subject to land use regulations except as necessary to implement the TSP.</p> <p>Transportation facilities and improvements are defined in DMC 17.501.020 to include the following:</p> <p><i>A. Construction of streets, walkways, and associated improvements as part of an approved subdivision, partition, design review, or similar application.</i></p> <p><i>B. Projects identified in the city's adopted transportation system plan.</i></p> <p><i>C. Installation of culverts, pathways, medians, fencing, guardrails, walls, lighting, and similar types of improvements.</i></p> <p><i>D. Normal operation, maintenance, repair, and preservation activities of existing transportation facilities.</i></p> <p><i>E. Landscaping as part of a transportation facility.</i></p>

	Recommended Development Code Amendments	Commentary
		<p><i>F. Transit stops.</i></p> <p>Transportation facilities and improvements, as currently defined in the Development Code, are recommended to be permitted outright in residential, commercial/employment, and public zones in Dundee (see Attachment A).</p> <p>New transportation facilities proposed in Agriculture (A) and Exclusive Farm Use (EFU) zones may potentially have a significant impact on land use, so transportation uses are proposed to be established as a conditional use in the A zone and to be regulated by ORS 215 in the EFU zone.</p> <p>Similarly, transit centers and park-and-ride lots may have impacts greater than a standard transit stop (which is included in the existing code definition of transportation uses). For that reason, transit centers and park-and-ride lots are proposed as conditional uses in all Dundee zones to address design issues and potential impacts.</p>
2.	<p><b>CHAPTER 17.301 ACCESS AND CIRCULATION</b></p> <p><b>17.301.020 Vehicular access and circulation.</b></p> <p>F. Approach Spacing. <del>The following distances</del> <u>Distances that shall separate driveway, intersection, and alley access to streets: are established according to street classification in the Dundee transportation system plan.</u></p>	<p>In accordance with City goals and policies to provide a safe transportation system and to protect the function of transportation facilities and to ensure consistency with TPR Subsection -0045(2)(a), access control standards are included in the City Development Code.</p>



Recommended Development Code Amendments		Commentary								
	<table border="1"> <thead> <tr> <th>Street Classification</th> <th>Approach Spacing</th> </tr> </thead> <tbody> <tr> <td>Arterial</td> <td>150 feet (+/- 20%), except as required for state highways</td> </tr> <tr> <td>Collector</td> <td>75 feet</td> </tr> <tr> <td>Local</td> <td>15 feet</td> </tr> </tbody> </table> <p>The city engineer, with approval of the roadway authority, may adjust the access spacing standards as necessary to address project or location specific issues such as topographic conditions, property configurations, or preservation of significant natural features. In such cases, the roadway authority may require additional mitigation to ensure adequate traffic operation and safety. Refer to Chapter 17.305 DMC for other applicable street standards and guidelines.</p>	Street Classification	Approach Spacing	Arterial	150 feet (+/- 20%), except as required for state highways	Collector	75 feet	Local	15 feet	<p>It is recommended that the access spacing standards in the Development Code be replaced with references to access spacing standards in the updated TSP. Advantages to this approach include ease in maintaining consistency between documents and simplifying the amendment process as updates are made to the TSP in the future.</p>
Street Classification	Approach Spacing									
Arterial	150 feet (+/- 20%), except as required for state highways									
Collector	75 feet									
Local	15 feet									
3.	<p><b>17.301.020 Vehicular access and circulation.</b></p> <p>[...]</p> <p>I. Circulation and Connectivity. New developments shall be required to provide a circulation system that accommodates vehicular and pedestrian traffic, as follows:</p> <p>1. In new subdivisions, except as restricted on arterial streets, a street or driveway intersection providing multi-modal connectivity and circulation for pedestrians, bicyclists, and automobiles shall occur not less than once for every 600 linear feet of street frontage, measured from street right-of-way line to street right-of-way line.</p>	<p>To create multi-modal connectivity, pedestrian access ways should be required – rather than just allowed for – where it is not possible to create street connections. The City requested that the steepness of slopes be specified in defining constraints.</p> <p>Access spacing standards are consistent between the TSP and Development Code.</p>								

	Recommended Development Code Amendments	Commentary
	<p>2. Where it is not practicable to provide a street connection at least every 600 feet, due to topography, existing development patterns, or similar constraints (e.g., railroad, <del>steep slopes</del> <u>greater than 10%</u>, wetland), the city <del>may</del> <u>shall</u> approve a pedestrian access way with a public access easement through the subject lot or tract. See DMC 17.301.030 for pedestrian access way standards.</p>	
<p>4.</p>	<p><b>17.301.030 Pedestrian access and circulation.</b></p> <p>[...]</p> <p>C. Site Layout and Design. To provide safe, direct, and convenient pedestrian circulation, developments shall contain pedestrian walkways as follows:</p> <p>1. Continuous Walkway System. The pedestrian walkway system shall extend throughout the development site and connect to adjacent sidewalks, if any, <u>to adjacent existing or planned transit stops</u>, and <u>to all</u> future phases of development, as applicable.</p>	<p>Existing Development Code provisions include basic pedestrian access and circulation provisions; the proposed amendment specifies connections to transit service and facilities. The proposed amendment supports existing and proposed City policies to improve intercity and intracity transit service. It is also consistent with TPR Subsections -0045(3)(b) and -0045(4)(b), which establish requirements to improve access to existing and planned transit service and facilities.</p>
<p>5.</p>	<p><b>17.301.030 Pedestrian access and circulation.</b></p> <p>[...]</p> <p>D. Pedestrian Access Way. Where a pedestrian access way is required in lieu of a standard street connection, pursuant to DMC 17.301.020(I) or Chapter 17.403 DMC (Land Divisions and Property Line Adjustments), the access way shall consist of a 10-foot minimum width concrete or asphalt surface within a 20-foot public right-of-way tract or <u>public access</u> easement. The city may adjust the widths and construction specifications as necessary based on expected usage, including the need for emergency vehicle access.</p> <p>1. <u>Cul-de-sac Access Way. An access way required to connect a cul-de-sac to another street, pursuant to DMC</u></p>	<p>These proposed amendments to the City's non-motorized connectivity standards support City goals and policies to provide a connected multi-modal transportation network and better meet TPR Subsection -0045(6). The amendments seek to improve connections within and between residential areas and neighborhood activity centers. Access ways are already defined in the Development Code. As defined and as required by DMC 17.301.030(D), access ways are intended to be multimodal connections that are wider than</p>

	Recommended Development Code Amendments	Commentary
	<p><u>17.305.030(J) shall be at least five feet wide within a 10-foot right-of-way tract or easement. The city may adjust the dimensions and specifications as needed.</u></p> <p><b>CHAPTER 17.305 PUBLIC IMPROVEMENTS AND UTILITIES</b></p> <p><b>17.305.030 Street standards.</b></p> <p>[...]</p> <p>J. Cul-de-Sacs. Cul-de-sacs shall have maximum lengths of 400 feet and serve not more than 18 dwelling units. All cul-de-sacs shall terminate with circular turnarounds. <u>Where required by the review authority Pursuant to DMC 17.301.030(D)(1), an access way at least five feet wide shall connect the cul-de-sac to another street.</u></p>	<p>required on-site walkways. Proposed language requires connectivity (access ways) in a specific situation where vehicular through-access is not provided or feasible (between cul-de-sacs and adjacent streets). Acknowledging the potentially constrained nature of lots in a cul-de-sac, the standard access way width is reduced to be more reasonably accommodated in these potentially constrained conditions.</p>
6.	<p><b>CHAPTER 17.304 PARKING AND LOADING</b></p> <p><b>17.304.030 General provisions.</b></p> <p>F. Development Standards. All parking and loading areas, except those for single-family dwellings and areas used exclusively for bicycle parking, shall be developed and maintained as follows:</p> <p><u>9. Portions of off-street parking areas may be developed or redeveloped for transit-related facilities and uses such as transit shelters or park-and-ride lots, subject to meeting all other applicable standards, including retaining the required minimum number of parking spaces.</u></p>	<p>City policy supports improvements to transit service and facilities in the city. TPR Subsection -0045(4)(e), which applies to areas served by public transit, requires that transit-related and transit-supportive uses be permitted in parking areas. Thus, it is proposed that existing parking standards be amended to explicitly allow portions of the parking areas to be developed or used for transit-related uses (e.g., bus shelters, park-and-ride centers).</p>
7.	<p><b>17.304.030 General provisions.</b></p> <p>F. Development Standards. All parking and loading areas, except those for single-family dwellings and areas used exclusively for bicycle parking, shall be developed and</p>	<p>Large parking lots can be perceived as an unfriendly pedestrian environment when they are designed with only the car in mind. The proposed</p>

Recommended Development Code Amendments	Commentary
<p>maintained as follows:</p> <p>[...]</p> <p><u>9. Internal pedestrian connections shall be provided in parking lots with greater than ten (10) parking spaces located in a commercial zone. These connections shall be a minimum of five (5) feet wide and distinguished from vehicular areas through changes in elevation or contrasting paving materials (such as light-color concrete inlay between asphalt). Paint or thermo-plastic striping and similar types of non-permanent applications may be approved for crossings of parking lot areas that do not exceed 24 feet in crossing length.</u></p> <p><u>10. Internal pedestrian connections shall be provided in parking lots with greater than thirty (30) parking spaces located in a non-commercial zone. These connections shall be a minimum of five (5) feet wide and distinguished from vehicular areas through changes in elevation or contrasting paving materials (such as light-color concrete inlay between asphalt). Paint or thermo-plastic striping and similar types of non-permanent applications may be approved for crossings of parking lot areas that do not exceed 24 feet in crossing length.</u></p> <p><b>CHAPTER 17.402 SITE DEVELOPMENT REVIEW</b></p> <p><b>17.402.040 Application submission requirements.</b></p> <p>[...]</p> <p>B. Site Development Review Information</p> <p>[...]</p> <p>2. Proposed Site Plan. The site plan shall contain the following information:</p> <p>[...]</p> <p>g. The location and dimensions of all parking and</p>	<p>amendments implement the City’s objective to provide a safe, continuous, and direct network of streets, access ways, and other improvements for pedestrian and bicycle circulation in the city, as well as specific recommendations from the 2013-2014 Transportation and Growth Management (TGM) Dundee Commercial Zones project.</p> <p>The amendments also are consistent with TPR Subsection - 0045(3)(b), which establishes requirements for several aspects of pedestrian and bicycle access and connectivity, with an emphasis on on-site circulation and connections to adjacent uses. Existing Development Code language largely complies with this TPR provision; however, there are aspects where compliance can be strengthened regarding pedestrian circulation in parking lots.</p>

	Recommended Development Code Amendments	Commentary
	<p>vehicle circulation areas (show striping for parking stalls and wheel stops);</p> <p>h. Pedestrian and bicycle circulation areas, including sidewalks, internal pathways, <u>pedestrian connections through parking lots pursuant to DMC 17.304.030(F)(9)</u>, pathway connections to adjacent properties, and any bicycle lanes or trails;</p> <p>i. Loading and service areas for waste disposal, loading and delivery;</p> <p>[...]</p>	
8.	<p><b>17.304.040 Automobile parking standards.</b></p> <p><u>D. Preferential Carpool/Vanpool Parking. Parking lots for commercial and office uses that have designated employee parking and more than 20 parking spaces shall provide at least 10% of the employee parking spaces (with a minimum of one space) as preferential long-term carpool and vanpool parking spaces. Preferential carpool and vanpool parking spaces shall be closer to the entrances of the building than other parking spaces, with the exception of ADA accessible parking spaces.</u></p>	<p>Because the City of Dundee is served by transit, TPR Subsection -0045(4) applies. Subsection (d) requires preferential carpool and vanpool parking in order to promote alternatives to commuting in a single-occupancy vehicle.</p> <p>The proposed addition to parking standards would require that preferential parking (i.e., located closer to the main employee entrance than other parking spaces, with the exception of ADA parking spaces) be provided for carpools and vanpools in parking lots meeting specified conditions. The new standards are proposed to apply to parking areas with designated employee parking, as specified in the TPR.</p>
9.	<p><b>17.304.050 Bicycle parking standards.</b></p> <p>At a minimum, required bicycle parking shall be consistent with the following standards and guidelines:</p>	<p>Proposed language would require bicycle parking at transit-related uses, consistent with TPR Subsection -0045(3)(a), which generally requires that</p>

	Recommended Development Code Amendments	Commentary
	<p>[...]</p> <p>C. Bicycle Parking Spaces. [...]</p> <p>Table 17.304.050(C) Minimum Bicycle Parking Spaces Required by Use</p> <p>Type of Use</p> <p><u>Transit centers and park-and-ride lots</u></p> <p>Minimum Number of Bicycle Spaces</p> <p><u>8 spaces</u></p>	<p>jurisdictions require bicycle parking for all proposed land uses, other than single-family residential.</p>
	<p><b>CHAPTER 17.305 PUBLIC IMPROVEMENTS AND UTILITIES</b></p> <p>17.305.020 Applicability.</p> <p>Table 17.305.020 Applicability of Public Improvement Requirements</p> <p><i>Amendments proposed to this table are presented in Attachment B.</i></p>	<p>City staff and participants in the Planning Commission/City Council work session gave direction to add sidewalk provisions to public improvement requirements for single-family residential development. The provisions include an allowance for a deferral where sidewalk improvements will be constructed through a larger project in the future.</p>
10.	<p><b>17.305.030 Street standards.</b></p> <p>[...]</p> <p>C. Street Location. The location, width, and grade of streets shall be considered in their relation to existing and planned streets, to topographical conditions, to public convenience and safety, and to the proposed use of the land to be served by the streets. <u>Refer to the city of Dundee transportation system plan and applicable local street network plans for the location of streets.</u></p> <p>[...]</p>	<p>Amendments are proposed to ensure that requirements for street location are consistent between the TSP and Development Code.</p>

	Recommended Development Code Amendments	Commentary
11.	<p><b>17.305.030 Street standards.</b></p> <p>[...]</p> <p>H. Improvements to Existing Streets.</p> <p>1. All projects subject to site development review, partition, or subdivision approval must construct a minimum of a three-quarter street improvement to all existing streets adjacent to, within, or necessary to serve the development. The city engineer may waive or modify this requirement where the applicant demonstrates that the condition of existing streets to serve the development meets city standards and is in satisfactory condition to handle projected traffic loads. Where a development has frontage on both sides of an existing street, full street improvements shall be required.</p> <p>2. The city may allow an applicant to record a "waiver of rights to remonstrance for streets and public utility improvements" in lieu of street improvements when the following criteria are met:</p> <ul style="list-style-type: none"> <li>a. The contiguous length of the existing street to be improved (including the portion of the existing streets that must be improved to serve the development) is less than 250 feet;</li> <li>b. The existing roadway condition and sections are adequate to handle existing and projected traffic loads; and</li> <li>c. Existing public utilities (water, sanitary sewer and storm sewer) located within the existing roadway are adequate, or can be improved without damaging the existing roadway surface.</li> </ul> <p>3. <u>A waiver of sidewalk, planter strip, and curb improvements is not permitted. A deferral of these improvements may be allowed by the city engineer and city administrator under the conditions specified in DMC</u></p>	<p>Existing Development Code provisions allow an applicant to record a construction deferral agreement and waiver of rights to remonstrance and pay a fee in lieu of street improvements.</p> <p>Amendments are proposed to enable more sidewalk infill and move toward the City's objective of a complete and safe pedestrian system. Proposed amendments allow deferral of sidewalk, planter strip, and curb improvements under an expanded set of specified conditions, as approved by the City Engineer and City Administrator. Waivers of these improvements are not permitted.</p>



	Recommended Development Code Amendments	Commentary
	<p><u>17.305.030(H)(2) and under one of the following conditions:</u></p> <ul style="list-style-type: none"> <li><u>a. When the improvements conflict with an adopted capital improvement plan;</u></li> <li><u>b. When the improvements would create a safety hazard;</u></li> <li><u>c. When there is not an existing or planned funded sidewalk on adjacent lots for the improvements to connect to; or</u></li> <li><u>d. When the improvements are deemed more appropriate as part of a larger project in the future.</u></li> </ul> <p><u>4. Deferrals of sidewalk improvements are not permitted when there is an existing curb along the frontage of the site or the site is abutting an existing sidewalk.</u></p> <p><u>5. Formation of a Local Improvement District will be required to complete the sidewalk system on one side of a block when that side of the block reaches one of the following thresholds:</u></p> <ul style="list-style-type: none"> <li><u>a. Deferrals have been approved for 50% of the block length; or</u></li> <li><u>b. Sidewalks have been installed on 50% of the block length.</u></li> </ul> <p><u>36. In lieu of the street improvement requirements outlined under this section, the review authority may elect to accept from the applicant monies to be placed in a fund dedicated to the future reconstruction of the subject street(s). The amount of monies deposited with the city shall be at least 100 percent of the estimated cost of the required street improvements (including associated storm drainage improvements), and may include more than 100 percent of the cost as required for inflation. Cost estimates shall be based from a</u></p>	

	Recommended Development Code Amendments	Commentary
	<p>preliminary design of the reconstructed street provided by the applicant's engineer and shall be approved by the city engineer...</p>	
<p>12.</p>	<p><b>17.305.030 Street standards.</b></p> <p>[...]</p> <p>O. General Right-of-Way and Street Improvement Widths. The following street design standards in the Dundee Public Works Design Standards apply to public streets, bikeways and sidewalks in the city of Dundee. These standards shall be the minimum requirements, except where modifications are permitted under subsection (P) of this section or upon approval of an engineering design modification request granted by the city engineer.</p> <p><del>Table 17.305.030(O) General Right of Way and Street Improvement Widths</del> [This indicates removal of the table and its associated notes.]</p>	<p>It is recommended that Table 17.305.030(O) be replaced with a reference to the street design standards in the Public Works Design Standards. Replacing tables of dimensional standards in the Development Code with references can help the City maintain consistency between documents and simplify the amendment process as updates are made in the future.</p>
<p>13.</p>	<p><b>17.305.030 Street standards.</b></p> <p>R. Transit Improvements. Development proposals for sites that include or are adjacent to existing or planned transit facilities, as shown in the Dundee transportation system plan or adopted regional transit plan, shall be required to provide any of the following, as applicable and as the review authority advises:</p> <ol style="list-style-type: none"> <li>1. Reasonably direct pedestrian connections between the transit facility and building entrances of the site. For the purpose of this section "reasonably direct" means a route that does not deviate unnecessarily from a straight line or a route that does not involve a significant amount of out-of-direction travel for users.</li> <li>2. A transit passenger landing pad accessible to disabled persons.</li> <li>3. An easement or dedication for a passenger shelter or</li> </ol>	<p>City policy signals a commitment to improving transit service and facilities in Dundee. In a similar vein, TPR Subsections - 0045(3)(b) and (c) set requirements to improve access to existing and planned transit service and facilities.</p> <p>Existing Development Code includes basic pedestrian access and circulation provisions, but it is proposed that it also specify standards for providing access to transit service and facilities and for providing transit-related amenities as part of development that is adjacent to existing or planned transit stops.</p>

	Recommended Development Code Amendments	Commentary
	<p><u>bench if such facility is identified in an adopted plan.</u></p> <p><u>4. Lighting at the transit facility.</u></p>	
14.	<p><b>17.305.030 Street standards.</b></p> <p><u>S. Transportation Impact Analysis (TIA)</u></p> <p><u>1. Purpose. The purpose of this section of the code is to implement Section 660-012-0045(2)(b) and (e) of the State Transportation Planning Rule that requires the city to adopt standards to protect the future operations of roadways and transit corridors and a process to apply conditions to development proposals in order to protect and minimize adverse impacts transportation facilities. This section establishes when a TIA must be submitted with a development application in order to determine whether conditions are needed to minimize impacts to and protect transportation facilities; what must be addressed in a TIA; and who is qualified to prepare the analysis. Where a TIA is required, approval criteria will ensure that there are adequate facilities for both motorized and non-motorized modes of transportation.</u></p> <p><u>2. Applicability. A TIA shall be required to be submitted along with a land use application if the proposal is expected to involve one or more of the following:</u></p> <p><u>a. The proposed development would generate 40 or more PM peak-hour trips. This applicability requirement may be waived by the city engineer if:</u></p> <p>(1) <u>A previous traffic study adequately addresses the proposal;</u></p> <p>(2) <u>Completed off-site and frontage improvements adequately mitigate traffic impacts; or</u></p>	<p>City policy calls for the protection of the function of transportation facilities. This is reinforced by TPR Subsection - 0045(2)(b), which requires that local regulations include standards to protect the operations of roads and major transit corridors.</p> <p>A Transportation Impact Analysis (TIA) requirement is a tool to ensure that proposed land use changes and future development are consistent with the planned transportation system. TIA requirements have been developed and reviewed as part of the TGM Commercial Zones Evaluation project. The final draft requirements are presented here.</p>

	Recommended Development Code Amendments	Commentary
	<p>(3) <u>The proposed use is not adjacent to an intersection that is functioning at a poor level of service.</u></p> <p>b. <u>The proposed development would generate less than 40 PM peak-hour trips but the proposed development is immediately adjacent to an intersection that is functioning at a poor level of service, as determined by the city engineer.</u></p> <p>c. <u>An increase in use of any direct property approach road to Highway 99W by 10 vehicles or more per day that exceed 20,000 pounds gross vehicle weight.</u></p> <p>d. <u>A new direct approach to Highway 99W is proposed.</u></p> <p>e. <u>A proposed development or land use action that the road authority states may contribute to operational or safety concerns on its facility(ies).</u></p> <p>f. <u>An amendment to the Dundee Comprehensive Plan or Zoning Map is proposed.</u></p> <p>3. <u>Requirements.</u></p> <p>a. <u>Pre-application Conference. For proposals that meet one or more of the thresholds in DMC 17.305.030(S)(2), the applicant shall attend a pre-application meeting in order to coordinate with the city engineer, and ODOT as necessary, to discuss the scope of a required TIA prior to submitting an application. ODOT will be invited to participate in the pre-application conference when an approach road to Highway 99W serves the subject property to ensure the completed TIA meets</u></p>	

	Recommended Development Code Amendments	Commentary
	<p><u>the requirements of both agencies.</u></p> <p>b. <u>Preparation. The TIA shall be prepared by an Oregon registered professional engineer qualified to perform traffic engineering analysis and will be paid for by the applicant.</u></p> <p>c. <u>Typical Average Daily Trips and Peak Hour Trips. The latest edition of the Trip Generation Manual, published by the Institute of Transportation Engineers (ITE), shall be used to gauge PM peak hour vehicle trips, unless the city engineer approves an alternative trip generation study or method to determine the average daily and peak hour trips of a proposed development.</u></p> <p>d. <u>Intersection-level Analysis. Intersection-level analysis shall occur at intersections identified in the pre-application conference involving the applicant, city engineer, and ODOT staff as necessary, pursuant to DMC 17.305.030(S)(3)(a).</u></p> <p>e. <u>Transportation Planning Rule Compliance. The requirements of the Transportation Planning Rule shall apply to those land use actions that significantly affect the transportation system, as defined by OAR 660-012-0060.</u></p> <p>4. <u>Study Area. The following facilities shall be included in the study area for all Transportation Impact Analyses:</u></p> <p>a. <u>All site-access points and intersections (signalized and unsignalized) adjacent to the proposed development site. If the site fronts an arterial or collector street, the analysis shall address all intersections and driveways along the site frontage and within the access spacing distances in the TSP extending out from the</u></p>	

	Recommended Development Code Amendments	Commentary
	<p><u>boundary of the site frontage.</u></p> <p>b. <u>All roads through and adjacent to the site.</u></p> <p>c. <u>All intersections needed for signal progression analysis.</u></p> <p>d. <u>In addition to these requirements, the city engineer may require analysis of any additional intersections or roadway links that may be affected by the proposed development.</u></p> <p>5. <u>Analysis Periods. To adequately assess the impacts of a proposed land use action, the following study periods, or horizon years, should be addressed in the transportation impact analysis where applicable:</u></p> <p>a. <u>Existing year.</u></p> <p>b. <u>Project Completion Year, Background (No-Build) Conditions. The conditions in the year in which the proposed land use action will be completed and occupied, but without the expected traffic from the proposed land use action. This analysis should account for all city approved developments that are expected to be fully built out in the in the project completion year, as well as all planned transportation system improvements.</u></p> <p>c. <u>Project Completion Year, Full Buildout. The background condition plus traffic from the proposed land use action assuming full build-out and occupancy.</u></p> <p>d. <u>Phased Years of Completion. If the project involves construction or occupancy in phases, the applicant shall assess the expected roadway and intersection conditions resulting from major development phases. Phased</u></p>	

	Recommended Development Code Amendments	Commentary
	<p><u>years of analysis will be determined in coordination with city staff.</u></p> <p>e. <u>20-Year or TSP Horizon Year. For planned unit developments, comprehensive plan amendments or zoning map amendments, the applicant shall assess the expected future roadway, intersection, and land use conditions as compared to approved comprehensive planning documents.</u></p> <p>6. <u>Approval Criteria. When a TIA is required, a proposal is subject to the following criteria, in addition to all criteria otherwise applicable to the underlying proposal:</u></p> <p>a. <u>The analysis complies with the requirements of DMC 17.305.030(S)(3);</u></p> <p>b. <u>The analysis demonstrates that adequate transportation facilities exist to serve the proposed development or identifies mitigation measures that resolve identified traffic safety problems in a manner that is satisfactory to the city engineer and, when state highway facilities are affected, to ODOT;</u></p> <p>c. <u>For affected non-highway facilities, the TIA establishes that Level of Service standards adopted by the city have been met; and</u></p> <p>d. <u>Proposed public improvements are designed and will be constructed to the street standards specified in DMC 17.305.030 and to the access standards in Chapter 17.301 DMC.</u></p> <p>7. <u>Conditions of Approval. The city may deny, approve, or approve a development proposal with conditions necessary to: meet operational and safety standards; provide the necessary right-of-way for improvements;</u></p>	



	Recommended Development Code Amendments	Commentary
	<p><u>and to require construction of improvements to ensure consistency with the future planned transportation system. Improvements required as a condition of development approval, when not voluntarily provided by the applicant, shall be roughly proportional to the impact of the development on transportation facilities. Findings in the development approval shall indicate how the required improvements directly relate to and are roughly proportional to the impact of development.</u></p> <p><b>CHAPTER 17.402 SITE DEVELOPMENT REVIEW</b></p> <p>17.402.040 Application submission requirements.</p> <p>All of the following information is required for a Type II site development review application submittal, except where the city planning official determines that some information is not pertinent and therefore is not required:</p> <p>A. General Submission Requirements.</p> <p>[...]</p> <p>3. <del>Traffic</del> Transportation impact analysis, as may be required by the city or other roadway authority pursuant to DMC 17.305.030(S).</p>	
15.	<p><b>17.305.030 Street standards.</b></p> <p><u>T. Planter Strips in Commercial Zones. Planter strips in commercial zones are not required to be entirely landscaped. The strips may include hardscape such as street furniture, other pedestrian amenities, and tree wells, in place of or in addition to standard landscaping.</u></p>	<p>This proposed amendment was requested as a clarifying amendment at the Planning Commission/City Council work session.</p>
16.	<p><b>CHAPTER 17.403 LAND DIVISIONS AND PROPERTY LINE ADJUSTMENTS</b></p>	<p>City staff requested that provisions be added to subdivision code that require the formation of homeowners</p>

Recommended Development Code Amendments	Commentary
<p><b>17.403.070 Final plat submission requirements and approval criteria.</b></p> <p>Final plats require review and approval by the city planning official prior to recording with Yamhill County. The final plat submission requirements, approval criteria, and procedure are as follows:</p> <p>A. Submission Requirements. The applicant shall submit the final plat within 18 months, or as otherwise provided for in DMC 17.403.030. The format of the plat shall conform to ORS Chapter 92. The final plat application shall include the following items:</p> <ol style="list-style-type: none"> <li>1. One original and one identical copy of the final plat for signature. The plat copies shall be printed on mylar, and must meet the requirements of the county recorder and county surveyor. The plat must contain a signature block for approval by the city administrator, in addition to other required signature blocks for county approval.</li> <li>2. Written response to conditions of approval assigned to the land division.</li> <li>3. A title report for the property, current within six months of the final plat application date.</li> <li>4. Copies of any required dedication, easement, or other documents.</li> <li>5. Copies of all homeowner’s agreements, codes, covenants, and restrictions, or other bylaws, as applicable. <u>This shall include documentation of the formation of a homeowner’s association, including but not limited to a draft homeowner association agreement regarding the maintenance of planter strips adjacent to the rear yard of proposed through lots.</u></li> <li>6. Copies of any required maintenance agreements for common property.</li> </ol>	<p>associations (HOAs) to maintain planter strips on the back sides of through lots in subdivisions.</p> <p>Further, it was requested at the Planning Commission/City Council work session that new subdivision code language be prepared that requires sidewalks to be constructed prior to final platting or bonded for five years. The City could then use the bond money to build the sidewalk if not complete within five years.</p>

	Recommended Development Code Amendments	Commentary
	<p><u>7. A five-year bond for sidewalk improvements, if the improvements are not constructed prior to the final plat.</u></p> <p><del>78.</del> Any other item required by the city to meet the conditions of approval assigned to the land division.</p>	
17.	<p><b>CHAPTER 17.501 DEFINITIONS</b></p> <p><b>17.501.020 Definitions.</b></p> <p><u>“Addition” means increase in floor area equal to or exceeding existing floor area, or value of improvements equal to or exceeding value of existing improvements on the site.</u></p> <p><u>“Remodel” means increase in floor area equal to or exceeding existing floor area, or value of improvements equal to or exceeding value of existing improvements on the site.</u></p>	<p>Existing site development requirements (DMC 17.402.020) apply to a series of development conditions including additions and remodels, but these terms are not currently defined in the development code. These definitions will be helpful in clarifying site development applicability as well as other references in the development code.</p> <p>The proposed definitions are based on the City’s existing thresholds for improvement of non-conforming development in DMC 17.104.040(E).</p>

Table 3: Recommended Public Works Design Standards Amendments

	Recommended Public Works Design Standards Amendments	Commentary
	<p><b>Division 2 (Streets):</b></p> <p>Section 2.7 Existing Street Classifications</p> <p>Section 2.9 Definitions and Terms (e.g., bike lanes, bike path, bike route )</p> <p>2.11 Improvement Standards by Street Classification</p> <p>2.20 Sidewalks (minimum sidewalk widths by street classification; sidewalk deferral conditions)</p>	<p>Changes will be made to the Public Works Design Standards sections indicated to the left in order to be consistent with the classifications and standards in Draft TSP.</p>

	Recommended Public Works Design Standards Amendments	Commentary
	<b>Appendix A Standard Detail Drawings:</b>  Minimum street sections	

DRAFT

## Attachment A: Proposed Amendments to Permitted Uses

### CHAPTER 17.202 ZONING REGULATIONS

Table 17.202.020: Zoning Use Table

P: Permitted Use; CU: Conditional Use; S: Special Use Requirements Apply; N: Not Permitted											
Uses	Residential			Commercial and Employment			Public and Agriculture			Special Use Requirements	
	R-1	R-2	R-3	C	CBD	LI	P	P O	A	EFU	
Wireless Communication Facilities	CU+S	CU+S	CU+S	CU+S	CU+S	S	S	N	CU+S	S	DMC 17.203.170, DMC 17.203.180 in EFU, see limits in OAR 660-33 In EFU
Transportation Facilities, per DMC 17.501.020 <sup>2</sup>	<u>P</u>	<u>P</u>	<u>P</u>	<u>P</u>	<u>P</u>	<u>P</u>	<u>P</u>	<u>P</u>	<u>P</u>	*	See limits in OAR 660-033 in EFU
Transit centers and park-and-ride lots	<u>CU</u>	<u>CU</u>	<u>CU</u>	<u>CU</u>	<u>CU</u>	<u>C</u> <u>U</u>	<u>C</u> <u>U</u>	<u>C</u> <u>U</u>	<u>CU</u>	<u>CU</u>	

\* Transportation uses in the EFU zone shall be regulated pursuant to OAR 660-033 and ORS 215.213 and ORS 215.283.

<sup>2</sup> For reference (and not to be included in the final amendment), transportation facilities and improvements are defined in DMC 17.501.020 to include the following:

- A. Construction of streets, walkways, and associated improvements as part of an approved subdivision, partition, design review, or similar application.
- B. Projects identified in the city's adopted transportation system plan.
- C. Installation of culverts, pathways, medians, fencing, guardrails, walls, lighting, and similar types of improvements.
- D. Normal operation, maintenance, repair, and preservation activities of existing transportation facilities.
- E. Landscaping as part of a transportation facility.
- F. Transit stops.

## Attachment B: Proposed Amendments to Public Improvement Requirements

Table 17.305.020 Applicability of Public Improvement Requirements

Land Use Activity	Fire Hydrant	Street Improvement	Water Hookup	Sewer Hookup	Storm Drain	Street Lights	Bike Lanes**	Sidewalks
Single-Family Home or Duplex	No*	C-2	Yes	Yes	Yes	No	No	C-2

Legend:

No = Not required.

\*Fire suppression sprinkler system may be required where hydrant standard not met.

\*\*Where required by the TSP.

Yes = Required

C = Conditional, as noted:

- C-1. Fire Hydrants for Commercial, Industrial Expansions, or Multifamily Uses. One or more fire hydrants are required as per the Uniform Building Code and Uniform Fire Code or if adequate fire flows are not available to the site. If the existing water lines are insufficient to provide adequate fire flows, water lines shall be upgraded to provide sufficient capacity.
- C-2. Street Improvements for Single-Family Dwellings. New single-family dwellings, which require a street extension, must provide street improvements to city street standards. For new single-family homes on unimproved rights-of-way, a sidewalk, landscaping strip, curb, gutter, and a minimum width of 20 feet of street paving shall be required. The paving shall comply with city public works standards and begin at the end of the existing street improvement and extend to the farthest point on the property fronting the right-of-way. For new single-family dwellings or significant additions to or remodels of single-family dwellings (as defined in DMC 17.501 [new proposed definitions]) on improved rights-of-way, sidewalks, curbs and planter strips are required per DMC 17.305.030(H)(3). A sidewalk deferral may be granted by the city administrator and city engineer where they determine that sidewalk improvements will be constructed through a larger project in the future.



720 SW Washington St.  
Suite 500  
Portland, OR 97205  
503.243.3500  
www.dksassociates.com

## MEMORANDUM

**DATE:** July 28, 2015

**TO:** Dundee TSP Update Project Management Team

**FROM:** Carl Springer, P.E., Ray Delahanty, AICP, Anastasia Roeszler, E.I.T.

**SUBJECT: Dundee Transportation System Plan Update  
Finance Program (Technical Memorandum #11 – Draft)**

---

The purpose of this memorandum is to present the transportation funding that is expected to be available through 2035. The funding assumptions will help prioritize the investments the City can make in the transportation system, and will be utilized to develop a set of transportation improvements that will likely be funded to meet identified needs through 2035.

### Current City Funding Sources

Two general funding sources are utilized by the City for transportation, a local gas tax and the State Highway Trust Fund. In addition to City-funded projects, new private development will lead some of the proposed transportation projects in Dundee.

The City has adopted a local, 2 cents per gallon gas tax for transportation improvements. State funds through the State Highway Trust Fund come from state motor vehicle fuel tax, vehicle registration fees, and truck weight-mile fees, and are distributed on a per capita basis. Cities and counties receive a share of State Highway Trust Fund monies. By statute, the money may be used for any road-related purpose, including walking, biking, bridge, street, signal, and safety improvements.

The state gas tax funds have previously failed to keep up with cost increases and inflation. With increased fuel efficiency of vehicles and the State's emphasis on reducing vehicle miles traveled, the real revenue collected has gradually eroded over time. The gas tax in Oregon increased on January 1, 2011 by six cents, to 30 cents per gallon. This was the first increase in the state gas tax since 1993.



**Revenue:** Current revenue sources are expected to provide about \$5.4 million through 2035. Over the past four years, Dundee averaged \$181,000 in State Highway Fund shared revenue and \$46,000 in local gas tax revenue. As a conservative estimate,<sup>1</sup> the same levels (\$181,000, and \$46,000 per year) were assumed in the future.

Dundee recently increased its utility franchise fees by 1.6 percent for PGE and 2 percent for Northwest Natural. The franchise fee increase is dedicated to street improvements, and is expected to raise \$43,000 per year for a total of \$860,000 through 2035.

State law requires that a minimum of one percent of the State gas tax and vehicle registration funds received must be set aside for construction and maintenance of walking and bicycling facilities. In Dundee, this represents approximately \$1300 per year and over \$26,000 through 2035.

**Expenditures:** Current expenditures are expected to top \$4.2 million through 2035 (based on revenue and expenditures over the past five years). The majority of the funds are spent on materials and services (about \$2.2 million through 2035). In addition, \$1.3 million will be spent on both personnel services and equipment reserve.

The City of Dundee is expected to contribute a significant local match for construction of Phase 1 of the Newberg-Dundee Bypass. The City will have debt service of \$20,000 a year over a 20-year period for a total of \$400,000.

Additionally, Dundee has committed \$18,500 per year to local street maintenance for a total of \$370,000 through 2035.

### **ODOT Highway Safety Improvement Program (HSIP) Funding**

With Oregon's funding under the HSIP increased significantly and direction from the Federal Highway Administration to address safety challenges on all public roads, ODOT will increase the amount of funding available for safety projects on local roads. Safety funding will be distributed to each ODOT region, which will collaborate with local governments to select projects that can reduce fatalities and serious injuries, regardless of whether they lie on a local road or a state highway.

To maintain commitments in the current Statewide Transportation Improvement Program (STIP) for 2013-2015 and because the development of 2016-2018 STIP is well underway, a reasonable expectation is to start the jurisdictionally blind safety approach in 2017. Meanwhile ODOT intends to implement a transition plan for 2013-2016. The transition will be developed to bridge the gap. Funding for local roads will be allocated to primarily focus on a few systemic

---

<sup>1</sup> The population growth rate in Dundee was assumed to be roughly the same as the cost inflation rate, therefore, existing revenues were maintained through 2035.

low cost fixes that can be implemented in the shorter timeframe<sup>2</sup>. It is expected that ODOT will allocate about \$1.5 million for improvements in Dundee over the planning horizon.

**Funds for Transportation Improvements:** Over \$1.1 million in city funds and about \$1 to \$2 million in ODOT funds are expected to be available for street improvement needs after accounting for estimated expenditures through 2035. These funds can potentially be spent on transportation improvement needs.

**Table 1: Dundee Transportation Funding (2014 Dollars)**

Revenue Source	Average Annual Amount	Estimated Amount Through 2035
State Highway Fund Shared Revenue	\$181,000	\$3,620,000
Local Motor Vehicle Fuel Tax	\$46,000	\$920,000
Franchise Fee Increase	\$43,000	\$860,000
<b>Total Revenues (4-year average)</b>	<b>\$270,000</b>	<b>\$5,400,000</b>
Expenditures	Average Annual Amount	Estimated Amount Through 2035
Personnel Services	\$61,000	\$1,220,000
Materials and Services	\$109,000	\$2,180,000
Equipment Reserve	\$4,000	\$80,000
ODOT Debt Service	\$20,000	\$400,000
Local Street Maintenance	\$18,500	\$370,000
<b>Total Expenditures (4-year average)</b>	<b>\$212,500</b>	<b>\$4,250,000</b>
<b>Revenue Over Expenditures (Available for Capital Improvements)</b>	<b>\$57,500</b>	<b>\$1,150,000</b>

<sup>2</sup> ODOT Jurisdictionally Blind Safety Program

## Project Investments

Taking the network approach to transportation system improvements, the projects in this plan fall within one of several categories:

- **Driving** projects to improve connectivity, safety and capacity throughout the City. Dundee identified 17 driving projects that will cost an estimated \$22.3 million to complete. In addition to the 17 individual driving projects, four downtown connectivity packages, including a group of street and traffic control projects, were evaluated and estimated. The preferred downtown connectivity alternative is expected to cost \$3.8 million.
- **Walking** projects for sidewalk infill on collector roadways, providing seamless connections for pedestrians on major routes throughout the City. Sidewalk infill on local roads will be addressed through city code changes and these projects are expected to be financed by developers or property owners. Dundee identified 13 walking projects on collector roadways that will cost an estimated \$4.4 million to complete. Some of these walking projects can be completed as part of collector upgrades identified under the Driving Projects category. These walking projects are not included in the overall \$4.4 million cost.
- **Traffic Control** projects to improve intersections, rail crossings, and pedestrian crossings. Dundee identified eight projects that will cost an estimated \$1 million to complete. Two more projects, improved pedestrian crossings with rectangular rapid flashing beacons on Highway 99W, will be installed as part of the ODOT TE Grant project.
- **Biking** projects including an integrated network of bicycle lanes and shared roadways to facilitate convenient travel citywide. Dundee identified 20 biking projects that will cost an estimated \$140,000 to complete.
- **Shared-Use Path** projects providing local off-street travel for walkers and cyclists. The citywide shared-use path vision includes 13 projects totaling an estimated \$3.6 million.
- **Transit** projects to enhance the quality and convenience for passengers. Dundee identified three transit projects totaling an estimated \$200,000. Transit projects are likely to be funded by development or other outside sources.
- **Parking Projects** to improve convenience for drivers. Dundee identified two parking projects that will cost an estimated \$1.6 million to complete.

Overall, Dundee identified 76 individual transportation solutions and a downtown connectivity solution, totaling an estimated \$37 million worth of investments. Some of the projects identified in the TSP may be funded through other sources. About \$16.4 million of the identified projects would be development-led, ODOT could lead \$1,500,000, and Yamhill County could lead \$70,000 in projects. Projects or portions of projects were assumed to be development-led based on the proportion of fronting property that is likely to develop or redevelop before 2035. This leaves \$19 million worth of investments to be funded by the City. Based on current funding levels, the City is expected to have funding shortfall of approximately \$17.9 million to fund the

projects included in the TSP. The City may wish to consider expanding its funding options in order to provide a reasonable funding strategy so improvements can be constructed in a timely manner. A breakdown of funding sources for each project category is provided in Table 2.

**Table 2: Project Funding**

Project Type	Development Lead	City Funded	ODOT Funded	County Funded	Total
<b>Driving</b>	\$13,300,000	\$12,000,000	\$800,000		\$26,100,000
<b>Walking</b>	\$900,000	\$3,500,000			\$4,400,000
<b>Traffic Control</b>	\$100,000	\$500,000	\$400,000		\$1,000,000
<b>Biking</b>	\$10,000	\$130,000			\$140,000
<b>Shared-Use Path</b>	\$1,200,000	\$2,000,000	\$300,000		\$3,600,000
<b>Transit</b>	\$100,000	\$50,000		\$70,000	\$200,000
<b>Parking</b>	\$800,000	\$800,000			\$1,600,000
<b>Total</b>	<b>\$16,400,000</b>	<b>\$19,000,000</b>	<b>\$1,500,000</b>	<b>\$70,000</b>	<b>\$37,000,000</b>

Likely funding sources for each project were determined based on the project location and whether or not the adjacent property was already developed. Projects on Highway 99W were assumed to be at least partially funded by ODOT, and projects outside the UGB, but not on Highway 99W were assumed to be funded by Yamhill County. Projects adjacent to undeveloped land were assumed to be development-led. In cases where part of a project was adjacent to developed land and part adjacent to undeveloped land (such as a road reconstruction where one side of the street is developed and the other is not) the funding source was split proportionally based on the amount of undeveloped and developed land. A complete breakdown of project funding is available in Attachment 1.

## Potential Additional Funding Sources

Transportation funding options include local taxes, assessments and charges, and state and federal appropriations, grants, and loans. All of these resources can be constrained based on a variety of factors, including the willingness of local leadership and the electorate to burden citizens and businesses; the availability of local funds to be dedicated or diverted to transportation issues from other competing City programs; and the availability of state and federal funds. Nonetheless, it is important for the City to consider all opportunities for providing, or enhancing, funding for the transportation improvements included in the TSP.

The following sources have been used by cities to fund the capital and maintenance aspects of their transportation programs. There may be means to begin to or further utilize these sources, as described below, to address existing or new needs identified in the TSP.

### System Development Charges

System development charges (SDC) are fees collected from new development and used as a funding source for all capacity adding projects for the transportation system. The funds collected can be used to construct or improve portions of roadways impacted by applicable development, such as the UGB expansion area. The SDC is collected from new development and is a one-time fee. The fee is based on the proposed land use and size, and is proportional to each land use's potential PM peak hour vehicle trip generation. The City of Dundee currently collects SDCs for parks, sewer, stormwater, and water, but not for transportation. The City may wish to pursue vehicle and/or pedestrian and bicycle SDC's to fund transportation projects for new developments. Many of the transportation improvements in the TSP would be 100 percent fundable through SDC's.

Dundee is expected to grow by about 750 households and about 870 jobs between 2000 and 2035. As an example of the revenue an SDC fee program could generate, an SDC rate of \$2,500 per peak hour trip for driving (similar to the fee collected in Newberg) and \$500 per peak hour trip for walking and biking, the City could potentially collect an additional \$3.6 million for driving projects and \$724,000 for walking and biking projects. A typical residential dwelling unit would be expected to pay around \$2,200 for driving and \$450 for walking and biking SDCs. If an SDC rate program is desired, a rate study would be required to determine appropriate fees based on capacity projects costs, growth potential, and local preferences.

### Transportation Utility Fee

A transportation utility fee is a recurring monthly charge that is paid by all residences and businesses within the City. The fee can be based on the number of trips a particular land use generates or as a flat fee per unit. It can be collected through the City's regular utility billing. Existing law places no express restrictions on the use of transportation utility fee funds, other

than the restrictions that normally apply to the use of government funds.<sup>3</sup> Some cities utilize the revenue for any transportation related project, including construction, improvements and repairs. However, many cities choose to place self-imposed restrictions or parameters on the use of the funds.

Assuming a flat fee of \$10.00 per month per water meter for both residential and commercial uses in the City (similar to the fee charged in Bay City), the City could collect an additional \$3.4 million for transportation related expenses through 2035.

### **Local Fuel Tax**

Fifteen cities (including Dundee) and two counties in Oregon have adopted local gas taxes ranging from one to five cents per gallon. The taxes are paid to the city monthly by distributors of fuel. Dundee's local gas tax is currently 2 cents per gallon, which brings in about \$3,000 per month in revenue. The City may want to consider increasing the local gas tax or seasonally adjusting the rate. Newport, for example, increases its local gas tax during the summer months to place more of a burden on visitors stopping in the City and paying the local gas tax. This means some of the costs for the transportation improvements in the City would be shared by non-residents. Assuming Dundee increased its local gas tax to five cents per gallon during the summer months (June through October); the local gas tax could bring an additional \$7,500 per month during the summer, and \$37,500 annually or \$750,000 through 2035. The process for presenting such a tax to voters would need to be consistent with Oregon State law as well as the laws of the City.

### **ODOT Statewide Transportation Improvement Program (STIP) Enhance Funding**

ODOT has modified the process for selecting projects that receive STIP funding. The new process follows a jurisdictionally blind approach, meaning local agencies can receive funding for projects off the state system. Preferred projects are expected to be those that enhance system connectivity and improve multi-modal travel options. With the updated TSP, the City will be well positioned to apply for STIP funding.

### **ODOT Highway Safety Improvement Program (HSIP) Funding**

With Oregon's funding under the HSIP increased significantly and direction from the Federal Highway Administration to address safety challenges on all public roads, ODOT will increase the amount of funding available for safety projects on local roads. Safety funding will be distributed to each ODOT region, which will collaborate with local governments to select projects that can reduce fatalities and serious injuries, regardless of whether they lie on a local road or a state highway.

To maintain commitments in the current Statewide Transportation Improvement Program (STIP) for 2013-2015 and because the development of 2016-2018 STIP is well underway, a reasonable expectation is to start the jurisdictionally blind safety approach in 2017. Meanwhile

---

<sup>3</sup> Implementing Transportation Utility Fees, League of Oregon Cities

ODOT intends to implement a transition plan for 2013-2016. The transition will be developed to bridge the gap. Funding for local roads will be allocated to primarily focus on a few systemic low cost fixes that can be implemented in the shorter timeframe<sup>4</sup>.

### **Local Hotel/Lodging Tax**

Many Oregon jurisdictions impose a local hotel tax. Dundee currently collects a hotel tax that brings in approximately \$33,000 per year. State law requires that 70 percent of the hotel tax revenue be used for tourism facilities and promotion and 30 percent go to the general fund. Tourism facilities could potentially include transportation projects such as public parking or pedestrian improvement projects that benefit tourism.

### **General Fund Revenues**

At the discretion of the City Council, the City can allocate General Fund revenues to pay for its Transportation program (General Fund revenues primarily include property taxes, use taxes, and any other miscellaneous taxes and fees imposed by the City). This allocation is completed as a part of the City's annual budget process, but the funding potential of this approach is constrained by competing community priorities set by the City Council. General Fund resources can fund any aspect of the program, from capital improvements to operations, maintenance, and administration. Additional revenues available from this source are only available to the extent that either General Fund revenues are increased or City Council directs and diverts funding from other City programs.

### **Urban Renewal District**

An Urban Renewal District (URD) would be a tax-funded district within the City. The URD would be funded with the incremental increases in property taxes that result from construction of applicable improvements. This type of tax increment financing has been used in Oregon since 1960. Use of the funding includes, but is not limited to, transportation. Improvements are funded by the incremental taxes, rather than fees. The Dundee charter requires voter approval for the creation of any URD.

### **Local Improvement Districts**

Local Improvement Districts (LIDs) can be formed to fund capital transportation projects. LIDs provide a means for funding specific improvements that benefit a specific group of property owners. LIDs require owner/voter approval and a specific project definition. Assessments are placed against benefiting properties to pay for improvements. LIDs can be matched against other funds where a project has system wide benefit beyond benefiting the adjacent properties. LIDs are often used for sidewalks and pedestrian amenities that provide local benefit to residents along the subject street.

---

<sup>4</sup> ODOT Jurisdictionally Blind Safety Program



### Debt Financing

While not a direct funding source, debt financing can be used to mitigate the immediate impacts of significant capital improvement projects and spread costs over the useful life of a project. Though interest costs are incurred, the use of debt financing can serve not only as a practical means of funding major improvements, but is also viewed as an equitable funding strategy, spreading the burden of repayment over existing and future customers who will benefit from the projects. The obvious caution in relying on debt service is that a funding source must still be identified to fulfill annual repayment obligations.

## Developing the Plan

Dundee must make investment decisions to develop a set of transportation improvements that will likely be funded to meet identified needs through 2035. The City is expected to have approximately \$1.1 million to cover the \$18.9 million in project costs not covered by private development or other agencies. Unless the City expands its funding options, most of the transportation solutions identified for the City are not reasonably likely to be funded through 2035. For this reason, the transportation solutions will be split into three categories. Those reasonably expected to be funded by 2035 were included in the Likely Funded Transportation System, those that may be funded if additional funding sources are identified are included in the Possibly Funded Transportation System, and the projects that are not expected to be funded by 2035 were included in the Aspirational Transportation System.

### Likely Funded Transportation System

The Likely Funded Plan identifies the transportation solutions reasonably expected to be funded by 2035 and have the highest priority for implementation. Using the nine goals (see Technical Memorandum #3- Goals, Objectives and Evaluation Criteria), the transportation solutions were evaluated and compared to one another. Greater value was placed on the projects stakeholders felt were most important to the community. About \$5.3 million worth of investments are included in the Likely Funded Transportation System, about \$1.7 million of which the City would be expected to fund. Planning level cost estimates for the projects are shown in Attachment 1.

**Table 3: Likely Funded Projects**

Project No.	Project	City Funds	Potential Additional Funds (source)	Total
DCO2	Downtown Connectivity	\$567,750	\$2,838,750 (Dev) \$378,500 (ODOT)*	\$3,785,000
I6	5 <sup>th</sup> Street Right Turn Lane	\$320,000	\$320,000 (ODOT)*	\$640,000
W11*	SE 10 <sup>th</sup> Street Sidewalk infill between 99W and Edwards Drive	\$840,000		\$840,000
	<b>Total</b>	<b>\$1,727,750</b>	<b>\$3,537,250</b>	<b>\$5,265,000</b>

\*Funding contingent on ODOT approval

### Possibly Funded Transportation System

The Possibly Funded Plan identifies transportation solutions that could be funded if the City develops new revenue sources. Possible new sources are summarized in Table 4:

**Table 4: Potential New Funding Sources**

Revenue Source	Estimated Amount Through 2035: General Transportation	Estimated Amount Through 2035: Walking and Biking Only	Estimated Amount Through 2035: Tourism Only
System Development Charges	\$3,600,000	\$724,000	
Transportation Utility Fee	\$3,400,000		
Local Gas Tax Increase	\$750,000		
Lodging Tax			\$460,000
<b>Total Revenue</b>	<b>\$7,750,000</b>	<b>\$724,000</b>	<b>\$460,000</b>

Using these potential new funding sources, the additional projects in Table 5 could be funded. More projects could be funded through other sources, such as development, state or federal funding, urban renewal districts, local improvement districts, and reallocating general fund and lodging tax revenues to transportation projects. The Possibly Funded Transportation System includes about \$18 million worth of investments, about \$8.2 million of which the City would be expected to fund. Planning level cost estimates for the projects are shown in Attachment 1.

**Table 5: Possibly Funded Projects**

Project No.	Project	City Funds	Potential Additional Funds (source)	Total
D5	Alder Street Extension to 99W	\$235,000	\$470,000 (Dev)	\$705,000
D9a	Alder Street Reconstruction between 7 <sup>th</sup> Street and Upland Drive	\$535,000		\$535,000
D9b	Alder Street Reconstruction between 7 <sup>th</sup> and 9 <sup>th</sup>	\$562,500	\$187,500 (Dev)	\$750,000
D11	8 <sup>th</sup> Street Connection to Riverside	\$264,000	\$1,056,000 (Dev)	\$1,320,000
D13	North-South Parkway along Bypass	\$2,633,000	\$5,267,000 (Dev)	\$7,900,000
C1*	5 <sup>th</sup> Street Midblock Crosswalk	\$5,000		\$5,000
C4*	Striped Crosswalk on 99W at 7 <sup>th</sup> Street		\$5,000 (ODOT) †	\$5,000
C5*	Hwy 99W/9 <sup>th</sup> Crosswalk		\$5,000 (ODOT) †	\$5,000
C6*	Striped Crosswalk on 99W at 11 <sup>th</sup> Street		\$5,000 (ODOT) †	\$5,000
W2*	1 <sup>st</sup> Street Sidewalk Infill between Dogwood and Birch of 99W	\$120,000		\$120,000
W3	5 <sup>th</sup> Street Sidewalk Infill from 99W to Dogwood Street	\$235,000	\$235,000 (Dev)	\$470,000

Project No.	Project	City Funds	Potential Additional Funds (source)	Total
W6*	9 <sup>th</sup> Street Sidewalks	\$982,500	\$327,500 (Dev)	\$1,310,000
W7*	Alder Street Sidewalks between 9 <sup>th</sup> and 11 <sup>th</sup> St	\$425,000		\$425,000
W8*	Edwards Drive Sidewalks from 6 <sup>th</sup> to 2nd	\$505,000		\$505,000
W9*	SE 5 <sup>th</sup> Street Sidewalk infill between Maple Street and Edwards Drive		\$75,000 (Dev)	\$75,000
W10*	Edwards Street Sidewalks from 8 <sup>th</sup> to Parks	\$190,000	\$190,000 (Dev)	\$380,000
W13*	Niederberger Road Sidewalks	\$205,000		\$205,000
B5/B6*	5 <sup>th</sup> Street Bike Lanes or Shared Roadway east of 99W	\$5000		\$5000
B8*	10 <sup>th</sup> Street Shared Roadway	\$5000		\$5000
B9/B10*	Alder Street Bike Lanes or Shared Roadway	\$15,000		\$15,000
B12*	8 <sup>th</sup> Street Bike Lanes	\$3333	\$6667 (Dev)	\$10,000
B15*	11 <sup>th</sup> Street Shared Roadway	\$5000		\$5000
B18	Edwards Dr Bike Lanes/Shared Roadway	\$5000		\$5000
B21*	3 <sup>rd</sup> Street Shared Roadway	\$5000		\$5000
B22*	6 <sup>th</sup> Street Shared Roadway	\$5000		\$5000
S1	6 <sup>th</sup> Street Trail Ext to Riverside		\$191,250 (Dev) \$63,750 (ODOT)	\$255,000
S4	8 <sup>th</sup> Street Conversion to Off-street Path	\$97,500	\$97,500 (Dev)	\$195,000
S5*	13 <sup>th</sup> Street Conversion to Off-street Path	\$47,500	\$47,500 (Dev)	\$95,000
S7*	Bike/Ped Undercrossing of Bypass at 10 <sup>th</sup> St	\$265,000	\$265,000 (ODOT)†	\$530,000
S9*	SUP Connection to Subdivision		\$110,000 (Dev)	\$110,000
S10*	3 <sup>rd</sup> Street SUP Connection to Upland Drive	\$155,000		\$155,000
S11	7 <sup>th</sup> to 5 <sup>th</sup> Connection to School		\$145,000 (Dev)	\$145,000
S12*	Viewcrest to Parking Lot SUP Connection	\$65,000		\$65,000
S13	11 <sup>th</sup> St SUP Connection to Fulquartz	\$118,750	\$356,250 (Dev)	\$475,000
R1	Parks Road RR Crossing Gates	\$100,000	\$100,000 (Dev) \$100,000 (ODOT) †	\$300,000
T6	Transit Service to Riverside		\$70,000 (Dev)	\$70,000
T7	Transit Loop Service	\$45,000	\$45,000 (YCTA)	\$90,000
P1	8 <sup>th</sup> Street Parking	\$375,000	\$375,000 (Dev)	\$750,000
	<b>Total</b>	<b>\$8,214,000</b>	<b>\$9,796,000</b>	<b>\$18,010,000</b>

\*Walking and biking project

†Funding contingent on ODOT approval

## Aspirational Transportation System

The projects and actions outlined within the Likely Funded System and Possibly Funded System will significantly improve Dundee's transportation system. If the City is able to implement a majority of the Likely Funded System and Possibly Funded System, nearly two decades from now Dundee residents will have access to a safer, more balanced multimodal transportation network.

The Aspirational Transportation System identifies those transportation solutions that are not reasonably expected to be funded by 2035, but many of which are critically important to the transportation system. Some of the projects will require funding and resources beyond what is available in the time frame of this plan. Others are contingent upon redevelopment that makes it possible to create currently missing infrastructure, such as sidewalk connections.

The Aspirational Transportation System includes about \$10.2 million worth of investments. Planning level cost estimates for the projects can be found in Attachment 1. Transportation solutions within the Aspirational Transportation System were recommended within several different priority/time horizons:

- Long-term Phase 1: Projects with the highest priority for implementation beyond the projects included in the Likely Funded and Possibly Funded Transportation Systems, should additional funding become available.
- Long-term Phase 2: Projects with the next highest priority for implementation beyond the projects included in the Likely Funded and Possibly Funded Transportation Systems, should additional funding become available.
- Long-term Phase 3: The last phase of projects to be implemented, should additional funding become available.

## Policy

The City of Dundee expresses policy support for several projects that will help improve the transportation system in Dundee, but are located outside of Dundee City Limits. These projects include:

**Table 6: Policy Supported Projects**

Project Number	Project	Jurisdiction	Estimated Cost
D6	Fox Farm Road Realignment	Yamhill County	\$950,000
B3/B4	9 <sup>th</sup> Street/Worden Hill Road bike lanes or on-street path	Yamhill County	\$1,745,000
S2	SUP Connection from Dayton to Edwards Road	Yamhill County	\$275,000
I1	Fox Farm Road/99W Traffic Signal	Yamhill County/ODOT	\$250,000

Project #	Project Name	Project Description	Total	Project Cost	Funded by Development	Funded by City	Funded by ODOT	Funded by County	Designation	Notes
Option 2	Downtown Connectivity	Option 2	5.2	\$3,785,000	\$2,838,750	\$567,750	\$378,500		Likely Funded	The traffic signal proposed in this option is contingent on meeting warrants. Preliminary warrant analysis shows warrants are not met for 2035 (worst case) traffic volumes. Without traffic signal between \$200,000 and \$300,000 can be subtracted from the cost.
D1	7th St Extension	7th St extension to Alder St	4.25	\$165,000	\$41,250	\$123,750			Phase 1	
D2	New Street	New street from 3rd St to 5th St	3.42	\$345,000	\$172,500	\$172,500			Phase 3	
D3	Maple St Extension	Maple St extension from 8th St to 7th St	4	\$430,000	\$215,000	\$215,000			Phase 2	
D4	13th St	13th St - new street from Alder St to Hwy 99W	4.42	\$445,000	\$222,500	\$222,500			Phase 2	
D5	Alder St Extension	Alder St extension to Hwy 99W	4.95	\$705,000	\$470,000	\$235,000			Possibly Funded	
D8	Edwards Rd Reconstruction	Edwards Rd reconstruction between 2nd St and 5th St	4.2	\$1,320,000		\$1,320,000			Phase 2	Cost includes W8
D9a	Alder St Reconstruction	Alder St reconstruction between 7th St and Upland Dr	4.2	\$535,000		\$535,000			Possibly Funded	
D9b	Alder St Reconstruction	Alder St reconstruction between 9th St and 7th St	4.2	\$750,000	\$187,500	\$562,500			Possibly Funded	
D10	8th St Reconstruction	8th St reconstruction between railroad and Edwards Rd	3.95	\$1,485,000	\$371,250	\$1,113,750			Phase 3	
D11	8th St Connection	8th Street connection to Riverside	4.95	\$1,320,000	\$1,056,000	\$264,000			Possibly Funded	Does not include section being built with Bypass
D12	New Street	New street from 5th St to 7th St	3.5	\$1,245,000	\$622,500	\$622,500			Phase 3	
D13	North South Parkway	North South Parkway	4.87	\$7,900,000	\$5,266,614	\$2,633,331			Possibly Funded	
D14	Edwards St Improvement	Improvement of Edwards to collector standards (8th-Parks)	4.2	\$1,370,000	\$685,000	\$685,000			Phase 1	Cost includes W10
D15	Parks Improvement	Improvement of Parks to collector standards (99W to Edwards)	4.2	\$2,390,000	\$597,500	\$1,792,500			Phase 2	Cost includes W12
D16	New Street	5th St to 7th St Connection	3.7	\$295,000	\$147,500	\$147,500			Phase 3	
D17	Niederberger/Parks Intersection	Safety improvements at Niederberger/Parks Intersection	4.1	\$760,000	\$0	\$380,000	\$380,000		Phase 1	
D18	Maple St Reconstruction	Maple St Reconstruction between 11th and Parks	3.7	\$820,000	\$410,000	\$410,000			Phase 1	
I5	5 <sup>th</sup> St/Hwy 99W	5 <sup>th</sup> Street phasing/signal upgrade (improve side street service)	3.5	\$50,000		\$25,000	\$25,000			With I6 - not included in total cost
I6	5 <sup>th</sup> St/Hwy 99W	Westbound right turn lane (5th/99W)	2.5	\$640,000		\$320,000	\$320,000		Likely Funded	Cost includes I5 and R2
R1	Parks Rd	Parks Rd RR Crossing Gates	4	\$300,000	\$100,000	\$100,000	\$100,000		Possibly Funded	
R2	5 <sup>th</sup> St	5 <sup>th</sup> St RR Crossing Gates	4	\$300,000	\$100,000	\$100,000	\$100,000			With I6 - not included in total cost
C1	5 <sup>th</sup> St	5 <sup>th</sup> St - midblock crosswalk to connect post office with school and park	6.95	\$5,000		\$5,000			Possibly Funded	
C2	Hwy 99W/1 <sup>st</sup> St	Crossing enhancements and RRFB							Outside Funding	
C3	Hwy 99W/13 <sup>th</sup> St	Crossing enhancements and RRFB							Outside Funding	
C4	Hwy 99W/7 <sup>th</sup> St	Striped Crosswalk	6.95	\$5,000			\$5,000		Possibly Funded	
C5	Hwy 99W/9 <sup>th</sup> St	Striped Crosswalk	6.95	\$5,000			\$5,000		Possibly Funded	
C6	Hwy 99W/11 <sup>th</sup> St	Striped Crosswalk	6.95	\$5,000			\$5,000		Possibly Funded	
W1	SW 1st St Sidewalks	1st St - sidewalks between Hwy 99W and Lone St	7.12	\$15,000	\$15,000				Phase 1	
W2	SW 1st St Sidewalks	1st St Sidewalk Infill	7.12	\$120,000		\$120,000			Possibly Funded	

W3	SW 5th St Sidewalks	5th St - sidewalks on north side along park frontage to Dogwood Dr	7.07	\$470,000	\$235,000	\$235,000			Possibly Funded	
W4	SW Dogwood St Sidewalks	Dogwood Dr - sidewalk infill	7.12	\$865,000	\$216,250	\$648,750			Phase 2	
W5	SW Upland Dr Sidewalks	Upland Dr Sidewalk infill	6.42	\$120,000	\$120,000				Phase 1	
W6	SW 9th St Sidewalks	9th St - sidewalks on both sides	7.32	\$1,310,000	\$327,500	\$982,500			Possibly Funded	
W7	SW Alder St Sidewalks	Alder St - sidewalks on both sides 9th to past 11th	7.32	\$425,000		\$425,000			Possibly Funded	
W8	SE Edwards Dr Sidewalks	Edwards Dr Sidewalks on both sides from 6th to 2nd	7.32	\$505,000		\$505,000			Possibly Funded	Part of D8 - Not included in total cost
W9	SE 5th St Sidewalks	SE 5th St Sidewalk infill	6.37	\$75,000	\$75,000				Possibly Funded	
W10	SE Edwards Dr Sidewalks	Edwards Dr Infill Sidewalks from 8th to Parks	7.32	\$380,000	\$190,000	\$190,000			Possibly Funded	Part of D14 - Not included in total cost
W11	SE 10th St Sidewalks	10th St - Sidewalks on north side from Hwy 99W to Cedar St and near Edward St, all along south side	7.32	\$840,000		\$840,000			Likely Funded	
W12	SE Parks Rd Sidewalks	Parks Rd - sidewalks on both sides between Hwy 99W and Edwards Rd	7.57	\$1,130,000	\$282,500	\$847,500			Phase 2	Part of D15 - Not included in total cost
W13	SW Niederberger Rd Sidewalks	Niederberger Rd Sidewalks	7.57	\$205,000		\$205,000			Possibly Funded	
										Bike projects are considered by looking at the entire corridor and quality of connection provided, not by individual project
B1	5th St	Bike lanes from Alder to 99W	6.03	\$10,000		\$10,000			Phase 2	
B2	Edwards Rd	Bike lanes south of 5th St	6.03	\$5,000		\$5,000			Phase 2	With D14
B5	5th St	5th Street bike lanes (east of 99W)	6.03	\$5,000		\$5,000			Possibly Funded	
B6	5th St	5th Street shared roadway (east of 99W)	5.05	\$5,000		\$5,000				Alternate to B5
B7	Parks Dr	Bike Lanes on Parks Dr	6.03	\$5,000		\$5,000			Phase 2	With D15
B8	10th St	10th St shared roadway	5.05	\$5,000		\$5,000			Possibly Funded	
B9	Alder Street	Alder Street bike lanes	6.03	\$15,000		\$15,000			Possibly Funded	With D9
B10	Alder Street	Alder Street shared roadway	5.05	\$15,000		\$15,000				Alternate to B10
B11	1st Street	1st Street shared roadway from Highway	5.05	\$5,000		\$5,000			Phase 3	Steep grades and limited connectivity
B12	8th Street	8th Street bike lanes (Riverside)	6.03	\$10,000	\$6,667	\$3,333			Possibly Funded	With D11
B13	7th Street	7th Street shared roadway	5.05	\$5,000		\$5,000			Phase 3	Parallel routes available
B14	Locust Street	Locust Street shared roadway	5.05	\$5,000		\$5,000			Phase 3	Parallel routes available
B15	11th Street	11th Street shared roadway (west of 99W)	5.05	\$5,000		\$5,000			Possibly Funded	
B16	Redhills Drive	Redhills Drive shared roadway	4.60	\$10,000		\$10,000			Phase 3	Steep grades and limited connectivity
B17	Dogwood Drive	Dogwood Drive shared roadway	4.60	\$5,000		\$5,000			Phase 2	
B18	Edwards Drive	Edwards Drive shared roadway	5.05	\$5,000		\$5,000			Possibly Funded	Priority connection
B19	1st Street	1st Street shared roadway from Brier Pl to Walnut St	4.80	\$5,000		\$5,000			Phase 3	Steep grades and limited connectivity
B20	Brier Place	Brier Place shared roadway	4.60	\$5,000		\$5,000			Phase 3	Steep grades and limited connectivity
B21	3rd Street	3rd Street shared roadway	4.80	\$5,000		\$5,000			Possibly Funded	Priority connection
B22	6th Street	6th Street shared roadway	5.05	\$5,000		\$5,000			Possibly Funded	
S1	6th St	6th Street trail extension to Riverside	8.52	\$255,000	\$191,250		\$63,750		Possibly Funded	Would ODOT fund?
S4	8th St	8th Street (west), conversion to off-street path	8.52	\$195,000	\$97,500	\$97,500			Possibly Funded	
S5	13th St	13th Street (west), conversion to off-street path	8.52	\$95,000	\$47,500	\$47,500			Possibly Funded	
S6	Viewmont to Fox Farm Rd	Trail connection between Viewmont and Fox Farm Road	8.02	\$350,000		\$350,000			Phase 2	
S7	10th St at Bypass	Bike/ped undercrossing of Bypass at 10th Street	8.52	\$530,000		\$265,000	\$265,000		Possibly Funded	Would ODOT fund?
S8	1st St Connection	1st St SUP Connection	8.52	\$220,000	\$110,000	\$110,000			Phase 3	Steep grades and limited connectivity
S9	SUP Connection to Subdiv	SUP Connection to Subdivision	8.77	\$110,000	\$110,000				Possibly Funded	
S10	3rd St Connection	3rd St Connection to Upland	8.77	\$155,000		\$155,000			Possibly Funded	Priority connection
S11	7th to 5th Connection	5th to 7th St connection to school	8.52	\$145,000	\$145,000				Possibly Funded	
S12	Viewcrest Connection	Viewcrest to Parking Lot Connection	8.52	\$65,000		\$65,000			Possibly Funded	



S13	11th St Connection	11th St SUP Connection to Fulquatz	8.77	\$475,000	\$356,250	\$118,750			Possibly Funded	Could be completed as part of Downtown Connectivity Project
S14	T Connection	T Connection from Walnut to Viewmont and Red Hills	8.77	\$660,000		\$660,000			Phase 3	Steep grades and limited connectivity
S15	Viewmont West Connection	Bike/ped connection between Laurel and cemetery	8.02	\$325,000	\$162,500	\$162,500			Phase 2	
T6	Riverside	Transit service to Riverside area	3.6	\$70,000	\$70,000				Possibly Funded	
T7	City Wide	Transit loop service (using Alder, Edwards)	3.6	\$90,000		\$45,000		\$45,000	Possibly Funded	
T8	Hwy 99W	Second pair of stops on 99W	3.1	\$45,000	\$22,500			\$22,500	Outside Funding	
P1	8th St	8th Street (west) parking capacity	2.5	\$750,000	\$375,000	\$375,000			Possibly Funded	
P2	10th St	10th Street Parking Capacity	1.5	\$825,000	\$412,500	\$412,500			Phase 3	
				\$36,965,000	\$16,499,281	\$18,900,914	\$1,547,250	\$67,500		

## Traffic Signal Warrant Analysis

This memorandum serves to document the analysis methods used to determine preliminary signal warrants for the preferred downtown connectivity alternative in Dundee, Oregon as part of the Dundee Transportation System Plan Update. The preferred option includes a new collector at 11<sup>th</sup> Street from Highway 99W to Parks Road, an improved rail crossing on 11<sup>th</sup> Street, and a new traffic signal at 11<sup>th</sup> Street/Highway 99W. Currently, 11<sup>th</sup> Street ends at Highway 99 and there is no connection east of the highway. The analysis shows that this intersection does not meet preliminary traffic signal warrants with projected 2035 traffic volumes.

The MUTCD provides a set of eight warrants to help determine whether a traffic signal should be considered at an intersection. In addition, ODOT Transportation Planning Analysis Unit (TPAU) has developed a set of preliminary traffic signal warrants based on MUTCD warrants but that require less data for analysis. TPAU uses Signal Warrants 1, Case A and Case B (MUTCD), which deal primarily with high volumes on the intersecting minor street and high volumes on the major-street. Meeting preliminary signal warrants does not guarantee that a signal shall be installed. Before a signal can be installed a field warrant analysis is conducted by the Region. If warrants are met, the State Traffic Engineer will make the final decision on the installation of a signal.

The target volume for the preliminary warrant can be reduced to 70 percent of normal requirements in cases where the 85<sup>th</sup> percentile speed of the major street exceeds 40 mph, or when the intersection lies within the built-up area of an isolated community having a population of less than 10,000. This intersection meets these requirements since it lies within the built up area of Dundee, an isolated community of less than 10,000 residents.

In MUTCD Warrant 1, the eighth highest hour of an average day is used to determine if the warrant is met. For preliminary signal warrant analysis, a conversion factor of 5.65 percent is applied to the ADT to reach the eighth highest hour.

In this analysis, the new connection was added to the 2035 average weekday travel demand model. Intersection volumes from the travel demand model were input into the ODOT Preliminary Traffic Signal Warrant Analysis Form. A K factor of 7.012 was developed for Highway 99W from 2012 weekday counts. The default K factor of 10 was used for 11<sup>th</sup> Street since it is a new connection and there are no existing traffic counts to work with. No right turn discount was applied since the volumes were based on travel demand modeling and not existing traffic counts.

The intersection does not meet preliminary signal warrants for either Case A or Case B. Traffic volumes on Highway 99W exceed those required for the warrant, but volumes on 11<sup>th</sup> Street do not exceed those required for the warrant, even with the 70 percent volume discount for isolated communities applied. This does not necessarily mean that a traffic signal will not be warranted in the future. After the 11<sup>th</sup> Street connection is built, the intersection can be re-evaluated with actual traffic counts to determine if MUTCD warrants are met.



720 SW Washington St  
Suite 500  
Portland, OR 97205  
503.243.3500

## DRAFT MEMORANDUM #12

**DATE:** May 5, 2015

**TO:** Dundee TSP Update Project Management Team

**FROM:** Carl Springer, P.E., DKS Associates  
Ray Delahanty, AICP, DKS Associates  
Anastasia Roeszler, E.I.T., DKS Associates

**SUBJECT: Dundee Transportation System Plan Update  
Transportation Standards**

---

This document provides recommendations for transportation standards and guidelines for streets maintained by Dundee. Included is an overview of street design types and documentation of standards and regulations to help ensure that future development or redevelopment of property is consistent with the vision of the transportation system in Dundee.

### Functional Classification

Functional classification of roadways is a common practice in the United States. Traditionally, a roadway is classified based on the type of travel it is intended to serve (local versus through traffic). The functional classification of a roadway determines the level of mobility for all travel modes, defining its level of access and usage within the City and region. The street functional classification system recognizes that individual streets do not act independently of one another but instead form a network that works together to serve travel needs on a local and regional level.

From highest to lowest intended usage, the classifications are arterials, collectors, and local streets. Roadways with a higher intended usage generally have a classification and related standards that promote more efficient vehicle movement through the City, while roadways with lower intended usage are classified to provide greater access to local destinations such as businesses or residences.

- **Arterial Streets** in Dundee consist solely of Highway 99W, which is classified by ODOT as Principal Arterial. Highway 99W has by far the highest traffic volumes in Dundee. It is the roadway that residents use to connect to locations outside the City, and the roadway that visitors use to reach and travel through Dundee. The posted speed limit on Highway 99W was recently reduced to 30 miles per hour through Dundee.

- **Collector Streets** in Dundee connect the neighborhoods and major activity generators to arterial streets. These streets provide greater accessibility to neighborhoods than arterials, and provide efficient through movement for local traffic. 9<sup>th</sup> Street is an example of a collector street that connects popular wineries just outside the City as well as local neighborhoods to Highway 99W. Collectors have a posted speed of 25 miles per hour within Dundee.
- **Local Streets** provide direct access to residences in Dundee. These roadways are often lined with residences and are designed to serve lower volumes of traffic with posted speeds of 25 miles per hour.

### Street Type

Dundee can further classify roadways within the City based on the neighborhoods they serve and their intended function for pedestrians, bicyclists, and transit riders. The street type of a roadway defines its cross-section characteristics and determines how users of a roadway interact with the surrounding land use. Since the type and intensity of adjacent land uses and zoning directly influence the level of use by pedestrians, bicyclists, and transit riders, the design of a street (including target speed, intersections, sidewalks, and travel lanes) should reflect its surroundings. The street types attempt to strike a balance between street functional classification, adjacent land use, zoning designation and the competing travel needs by prioritizing various design elements.

- **Mixed-Use Streets** typically have a higher amount of pedestrian activity and are often on a transit route. These streets should emphasize a variety of travel choices such as pedestrian, bicycle and transit use to complement the development along the street. Since Mixed-Use Streets typically serve pedestrian-oriented land uses, walking should receive the highest priority of all the travel modes. They should be designed with features such as wider sidewalks, pedestrian amenities, transit amenities, attractive landscaping, on-street parking, pedestrian crossing enhancements and bicycle lanes.
- **Residential Streets** are generally surrounded by residential uses, although various small shops may be embedded within the neighborhood. These streets often connect neighborhoods to local parks, schools and mixed-use areas. They should be designed to emphasize walking, while still accommodating the needs of bicyclists and motor vehicles. A high priority should be given to design elements such as traffic calming, landscaped buffers, walkways/pathways/trails, on-street parking and pedestrian safety enhancements.
- **Commercial/Industrial Streets** are primarily lined with retail and large employment complexes, and often serve industrial areas. These uses serve customers throughout the City and region and may not have a direct relationship with nearby residential neighborhoods. Dundee's commercial code standards require buildings to be near the street and are meant to encourage pedestrian activity. Therefore, although commercial streets will be somewhat auto oriented, they should still accommodate pedestrians and bicyclists safely and comfortably. Roadway widths are typically wider to accommodate a high volume of large vehicles such as trucks, trailers and other delivery vehicles.

Design features should include curb-tight sidewalks, on-street parking, and pedestrian crossing enhancements. Bicycles should be accommodated through shared-lane markings and plentiful bicycle parking. Sidewalks should be constructed in accordance with the commercial design guidelines in the Dundee Development Code.

- **Constrained streets.** Any street type located in steep, environmentally sensitive, rural, historic, or development-limited areas of the City may be considered a constrained street. These streets may require different design elements that may not be to scale with the adjacent land use. Constrained elements may include narrower or limited travel lanes, and pedestrian and bicycle facilities, or accommodations that generally match those provided by the surrounding developed land uses. To the extent possible, pedestrian and bicycle accommodations should be provided on an adjacent roadway, via a shared-use path or shared within the right-of-way using distinctive design details.

### Multi-Modal Roadway Cross Sections

Design of the streets in Dundee requires attention to many elements of the public right-of-way and considers how the street interacts with the adjoining properties. Four zones comprise the cross-section of streets in Dundee, including the context zone, walking zone, biking/on-street parking zone, and driving zone. The design of these zones varies based on the functional classification and street type.

- **Context Zone:** The context zone is the point at which the sidewalk interacts with the adjacent buildings or private property. The purpose of this zone is to provide a buffer for land use adjacent to the street and to ensure that all street users have safe interactions.
- **Walking Zone:** This is the zone in which pedestrians travel. The walking zone is determined by the street type and should be a high priority in mixed-use and residential areas. It includes a minimum five foot clear throughway for walking, an area for street furnishings or landscaping (e.g. benches, transit stops and/or plantings) and a clearance distance between curbside on-street parking and the street furnishing area or landscape strip (so parking vehicles or opening doors do not interfere with street furnishings and/or landscaping). Streets located along a transit route should incorporate furnishings to support transit ridership, such as transit shelters and benches, into the furnishings/landscape strip adjacent to the biking/on-street parking zone.
- **Biking/On-Street Parking Zone:** This is the zone for biking and on-street parking, and is the location where users will access transit. The biking/on-street parking zone is determined by the street type and should be a high priority in mixed-use and residential areas, which should include on-street parking with a minimum 6 foot striped bike lane or 5 foot bike lane with a 2 foot buffer. Streets in commercial/employment or industrial areas should include minimum 6 foot bike lanes or 5 foot bike lane with a 2 foot buffer, with no on-street parking.
- **Driving Zone:** This is the throughway zone for drivers, including cars, buses and trucks and should be a high priority in commercial/ employment and industrial areas. The functional classification of the street generally determines the number of through lanes, lane widths, and

median and left-turn lane requirements. However, the route designations (such as transit street or freight route) take precedence when determining the appropriate lane width in spite of the functional classification. Wider lanes (between 13 to 14 feet) should only be used for short distances as needed to help buses and trucks negotiate right-turns without encroaching into adjacent or opposing travel lanes. Streets that require a raised median should include a minimum 6 foot wide pedestrian refuge at marked crossings. Otherwise, the median can be reduced to a minimum of 4 feet at midblock locations, before widening at intersections for left-turn lanes (where required or needed).

Figures 1 through Figure 7 illustrate the different roadway classifications in Dundee. There is no cross section for arterial streets since the only arterial street is Highway 99W, which is subject to design criteria in the Oregon Highway Plan and ODOT Highway Design Manual, not Dundee City standards.

**Collector Streets**

The Collector cross section shown in Figure 1 is the design standard primarily used in Dundee. This collector street consists of two travel lanes with on-street parking. The travel lanes should be designated as shared space for both motor vehicle and bicycle traffic by using shared-lane markings (sharrows). In commercial districts the planter strip may be omitted in favor of wider, curb tight sidewalks.



**Figure 1: Collector - Two Travel Lanes with Parking and Shared-Lane Markings**

The constrained collector is intended for streets with narrow right-of-way, geographic constraints, or both. Parking and bike lanes are omitted and the two 14' travel lanes may be designated as shared space for motor vehicles and bicycles with sharrows. Sidewalks will be constructed on one side of the roadway in consultation with the city engineer.

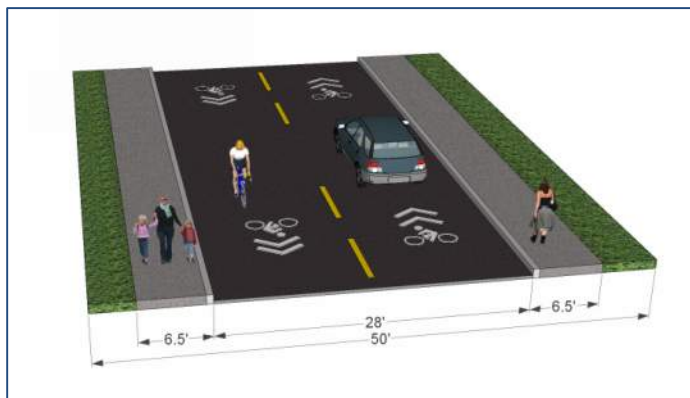

**Figure 2: Constrained Collector**



The Parkway Collector standard shown in Figure 3 should be used in the Riverside District to help establish the special character of the District, and on streets connecting downtown Dundee with the Riverside area. Collector streets designated as Parkway Collectors include the new north-south collector in Riverside, Fulquartz Landing, 11<sup>th</sup> Street, Edwards Drive, and 5<sup>th</sup> Street. Parkway Collector roadways use the same amount of right-of-way as regular collector streets and may include either bike lanes or a twelve-foot shared-use path on one side. On-street parking is not allowed on Parkway Collector roadways.

The new north-south collector in the Riverside District should include the twelve-foot shared-use path on one side as shown in Figure 3: Parkway Collector with Shared-Use Path Figure 3. All other streets designated as Parkway Collectors should include bike lanes as shown in Figure 4.



Figure 3: Parkway Collector with Shared-Use Path



Figure 4: Parkway Collector with Bike Lanes

## Local Streets

There are two types of local streets allowed under Dundee's design standards. Local I, the City's preferred design, and Local II, which must be built if Local I requirements cannot be met. The Local I design standard shown in Figure 5 includes on-street parking on both sides of the street. Sharrows can be used on a Local I street if it is part of a designated bike route, but they are not required. Outside the Riverside District the street trees and planter strip may be omitted due to utility conflicts, right-of-way needs, or geographical constraints.



**Figure 5: Local Street I - Two Travel Lanes with On-Street Parking on Both Sides**

Local II standard must be built if the Local I street requirements cannot be met. The Local II design standard shown in Figure 6 includes on-street parking on both sides of the street. Due to the narrow cross section, cars will need to pull aside and wait for opposing traffic if there are cars parked on both sides. Sharrows can be used on a Local II street if it is part of a designated bike route, but they are not required. Local II streets have the following requirements:

- The street shall connect with other streets and not terminate in a cul-de-sac.
- Subdivisions and other developments shall be limited to a maximum block length of 400 feet.
- The street grade shall not exceed four percent.
- The street layout must be capable of accommodating the largest emergency vehicle in the fire department.
- The narrower street shall not be used to extend existing streets that contain wider rights-of-way or improvements.

Like the Local I street, outside the Riverside district the street trees and planter strip may be omitted due to utility conflicts, right-of-way needs, or geographical constraints.



**Figure 6: Local Street II - Two Travel Lanes with On-Street Parking on Both Sides**

A unique local street cross section was developed for the proposed SW 8<sup>th</sup> Street parking project, and may be appropriate to be utilized on SW 10<sup>th</sup> Street and SW 13<sup>th</sup> Street. This cross section is still in the planning stages and may include different elements from those depicted in Figure 7. SW 8<sup>th</sup> Street should be a one-way, low-traffic, and low-speed street primarily intended for parking and bicycle and pedestrian access. A shared-use path may be constructed next to the parking area for enhanced pedestrian and bicycle access.



**Figure 7: Parking - SW 8th Street**

## Shared-Use Paths

Shared-use paths provide off-roadway facilities for walking and biking travel. Depending on their location, they can serve both recreational and general travel needs. Shared-use path designs vary in surface types and widths. Harder surfaces are generally better for bicycle travel. Widths should provide ample space for both walking and biking and should also be able to accommodate maintenance vehicles. The design criteria for shared-use paths can be seen in Figure 6. The City may reduce the width of the paved shared-use path to a minimum of eight feet in constrained areas located in steep, environmentally sensitive, rural, historic, or development-limited areas of the City. In areas with significant walking or biking demand, the paved shared-use path should be 16 feet. In addition, a variety of amenities can make a path inviting to the user. These could include features such as interpretive signs, water fountains, benches, lighting, maps, art, and shelters.

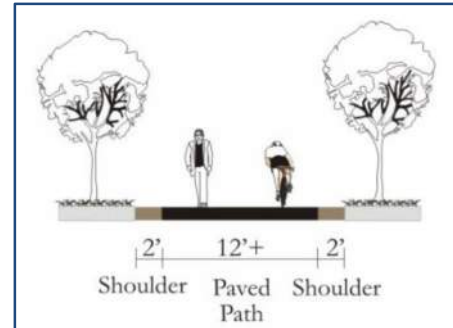

Figure 8: Design Criteria for Shared-Use Paths

## Mobility Standards

Mobility can be measured either by Level of Service (LOS), The City of Dundee requires Level of Service (LOS) “D” as the minimum acceptable performance standard for City streets. This standard applies to all of the streets in Dundee except, Highway 99W, which is a state facility whose mobility target is set by the Oregon Transportation Commission (OTC) in the Oregon Highway Plan (OHP).

The ODOT mobility target for Highway 99W is 0.85 volume to capacity (v/c).

All of the study intersections in Dundee area expected to meet these mobility targets with the exception of Highway 99W/Fox Farm Road and Highway 99W/5<sup>th</sup> Street. The Highway 99W/Fox Farm Road intersection is under Yamhill county and ODOT jurisdiction, and is expected to be addressed under the Yamhill County TSP. The 5<sup>th</sup> Street intersection can meet mobility targets if improved by the Highway 99W/5<sup>th</sup> Street right turn lane project identified in the reasonably likely funded scenario. However, even with this improvement, the same conditions seen today, with long queues southbound on Highway 99W and vehicles waiting through multiple cycles to progress through the intersection, are likely to return as traffic returns to present levels along Highway 99W.

## Design and Analysis Guidelines

Design and analysis guidelines allow cities to shape the character and functionality of the transportation system. In Dundee, these guidelines are used to provide standards for connectivity, access spacing, traffic impact analysis, neighborhood traffic management, intelligent transportation systems coordination, and bicycle boulevard, enhanced pedestrian crossing, and on-street parking treatments.

**Local Street Connectivity**

Local street connectivity in Dundee is managed through circulation and connectivity standards. New developments are required to provide a circulation system that accommodates vehicle and pedestrian traffic as follows. In new developments, a street or driveway intersection that provides multi-modal connectivity and circulation for pedestrians, bicyclists, and automobiles must be provided at least once every 600 linear feet of street frontage. The exception is along Highway 99W where state access spacing requirements apply. In places where it is not practical to provide a street connection every 600 feet due to topography, existing development, or other constraints, the city may approve a pedestrian access easement through the subject lot or tract instead.<sup>1</sup>

Collector streets shall be located wherever necessary to carry traffic volumes higher than local street standards, or where the street provides primary access to Highway 99W. In general, collectors are spaced ¼ mile apart.

**Roadway and Access Spacing**

Access spacing along Dundee streets is managed through access spacing standards. Access management is a broad set of techniques that balance the need to provide efficient, safe, and timely travel with the ability to allow access to individual destinations. Proper implementation of access management techniques will promote reduced congestion and accident rates, and may lessen the need for additional highway capacity.

Table 1 identifies the minimum private access spacing standards for streets in Dundee. Within developed areas of the City, streets not complying with these standards could be improved with strategies that include shared access points, access restrictions (through the use of a median or channelization islands) or closed access points as feasible. New streets or redeveloping properties must comply with these standards, to the extent practical (as determined by the City).

**Table 1: Access Spacing Standards**

Facility	Minimum Access Spacing Standard <sup>2</sup>
ODOT Statewide Highway (Urban)	500 feet
City of Dundee Collectors	75 feet
City of Dundee Local Streets	15 feet
Yamhill County public roads	500 feet

<sup>1</sup> Dundee Development Code, Chapter 17.301 Access and Circulation

<sup>2</sup> Source: Table 4 in Oregon Administrative Rules 734-51, <http://www.oregon.gov/ODOT/HWY/ACCESSMGT/docs/pdf/734-051.pdf>  
 Dundee Development Code, Chapter 17.301 Access and Circulation  
 Yamhill County TSP, Access Management Policy 8



### Traffic Impact Analysis (TIA) Requirements

A TIA is a study to assess the impacts of a land use action or proposed development on the transportation system and identify mitigation for any capacity or safety deficiencies. Submission of a TIA to the City shall be required with a land use application if the proposal is expected to involve one or more of the following:

- The proposed development generates 40 or more PM peak-hour trips. This requirement may be waived by the city engineer if:
  - A previous traffic study adequately addresses the proposal
  - Already completed off-site and frontage improvements adequately mitigate traffic impacts
  - The proposed use is not adjacent to an intersection functioning at a poor level of service
- The proposed development would generate less than 40 PM peak-hour trips, but the proposed development is immediately adjacent to an intersection that is functioning at a poor level of service.
- An increase in use of any direct property approach road to Highway 99W by 10 vehicles or more per day that exceed 20,000 pounds gross vehicle weight.
- A new direct property approach road to Highway 99W is proposed.
- A development or land use action that the road authority states may contribute to operational or safety concerns on its facility(ies).
- An amendment to the Dundee Comprehensive Plan or Zoning Map.

### An amendment to the Dundee Comprehensive Plan or Zoning Map. Neighborhood Traffic Management Tools

Traffic calming is a form of neighborhood traffic management that can be used to create safe, slow streets (primarily in residential and mixed-use areas) without significantly changing vehicle capacity. Traffic calming can mitigate the impacts of traffic on neighborhoods and business districts where a greater balance between safety and mobility is desired. It seeks to influence driver behavior through physical and psychological means, resulting in lower vehicle speeds or through traffic volumes. Physical traffic calming techniques include:

- Narrowing the street by providing curb extensions or bulbouts, or mid-block pedestrian refuge islands
- Deflecting the vehicle path vertically by installing speed humps, speed tables, or raised intersections



Figure 9: Pedestrian Refuge Island in Vancouver, Washington

- Deflecting the vehicle path horizontally with chicanes, roundabouts, or mini-roundabouts

Narrowing travel lanes and providing visual cues such as placing buildings, street trees, on-street parking, and landscaping next to the street also create a sense of enclosure that prompts drivers to reduce vehicle speeds.

Traffic calming measures must balance the need to manage vehicle speeds and volumes with the need to maintain mobility, circulation, and function for service providers (e.g. emergency response).

Table 2 lists common traffic calming applications and suggests which devices may be appropriate along various streets in the City. Any traffic calming project should include coordination with emergency response agency staff to ensure public safety is not compromised.

**Table 2: Traffic Calming Measures by Street Functional Classification**

Traffic Calming Measure	Is Measure Appropriate? (per Roadway Classification)**	
	Collector*	Local Street*
Narrowing travel lanes	Yes	Calming measures are generally supported on local streets that are lesser response routes that have connectivity (more than two accesses)
Placing buildings, street trees, on-street parking, and landscaping next to the street	Yes	
Curb Extensions or Bulbouts	Yes	
Roundabouts	Yes	
Mini-Roundabouts	Yes	
Medians and Pedestrian Islands	Yes	
Pavement Texture	Yes	
Speed Hump or Speed Table	No	
Raised Intersection or Crosswalk	No	
Speed Cushion (provides emergency pass-through with no vertical deflection)	Yes	
Choker	No	
Traffic Circle	No	
Diverter (with emergency vehicle pass through)	Yes	
Chicanes	No	

\*Any traffic calming project should include coordination with emergency agency staff to ensure public safety is not compromised.

\*\* Traffic calming may be considered for state highways but would be required to meet ODOT standards, including any ODOT approved design exceptions.

### ITS Coordination Guidelines

Intelligent Transportation System (ITS) planning and coordination is important for Dundee to consider. Future ITS applications might include traveler information on the Newberg-Dundee Bypass, or traffic signal communications systems. The City, Yamhill County, and ODOT should



coordinate locations of potential fiber lines or other communications systems and coordinate potential cost saving measures, such as laying conduit for a future fiber network as part of a lighting project.

### Bicycle Treatment Guidelines

Collector streets will be required to accommodate bicycle facilities such as striped bike lanes, shared-use paths, or shared lane markings. Local streets generally have low speeds and low traffic volumes, so bicycles will share the roadway in those areas without special markings unless the local street is part of a designated bike route or critical connection.

### Bicycle Facility Treatment Guidelines

A network of family-friendly biking routes is envisioned to connect major destinations and neighborhoods in Dundee. These will include two different types of facilities, Parkway Collectors and bicycle boulevards.



**Figure 10: Bicycle Boulevard with Sharrows (SLMs) and Traffic Calming in Portland, Oregon**

As described in the preceding sections, Parkway Collectors will include either bike lanes or an adjacent shared-use path. Other collector roads and local streets that are part of a designated bicycle route will be low-speed shared facilities. These routes, sometimes referred to as bicycle boulevards, modify existing low volume, low speed streets to prioritize the through movement of bicyclists and pedestrians while maintaining local access for automobiles. Bicycle boulevards typically include wayfinding signage and pavement markings called shared-lane markings (SLMs) or “sharrows,” as well as traffic calming features that reduce motor vehicle speeds and volumes. Where these facilities cross major roadways it is important to provide safe and comfortable pedestrian and bicycle crossings.

Further enhancements may include “green street” features such as bio-swales and street trees, in addition to wider sidewalks and improved pedestrian amenities (e.g., benches and pedestrian-scale lighting). A network of bicycle boulevards helps encourage active transportation by providing comfortable, low-stress routes between neighborhoods and local parks, schools, and shopping areas. The bicycle boulevard network is generally off the main street system to attract less experienced walkers and bikers. It is generally envisioned to act like a linear park system linking parks, schools, jobs and other destinations in the City through a network of on-street shared-use streets and off-street shared-use paths.

## Sidewalk Policy

Dundee will work to improve and expand pedestrian facilities throughout the community. Sidewalks shall be included on all new streets within the urban growth boundary. All streets will be required to include sidewalks on both sides of the street unless limited by topography or environmental constraints, such as steep grades or narrow right-of-way.

## Enhanced Pedestrian Crossing Treatment Guidelines

Enhanced street crossings are generally required on roadways with high traffic volumes and/or speeds in areas with nearby transit stops, residential uses, schools, parks, shopping and employment destinations. These crossings should include treatments such as marked crosswalks, high visibility crossings, and curb extensions to improve the safety and convenience of street crossings. If the maximum block size is exceeded, mid-block pedestrian and bicycle accessways should be provided at spacing no more than 330 feet, unless the connection is impractical due to inadequate sight distance, high vehicle travel speeds, or other factors that may prevent the crossing (as determined by the City). Otherwise, the crossings should be provided consistent with the connectivity standards. This requirement is a proposed amendment to City code.

## On-Street Parking Dimensions

On-street parking should be a high priority along Mixed-Use or Residential streets (in mixed-use and residential areas). The design criteria for collector streets in mixed-use and residential areas (see Figure 1) calls for on-street parking on both sides of the street if bike lanes are not present. On-street parking is generally discouraged along Commercial/Industrial streets, although it may be allowed if the adjacent land use would benefit from it and adequate right-of-way is available. On local streets, on-street parking is generally provided on one side of the street, although on-street parking can be provided on both sides if a Local II street is required (see Figures 3 and 4). The City may eliminate on-street parking from one or both sides along streets located in constrained areas located in steep, environmentally sensitive, rural, historic, or development limited areas of the City.

The width of on-street parking should be eight feet, except along Residential streets where parking turn-over is not as frequent (as shown in Table 3). Along Residential streets, the width of on-street parking can be reduced to seven feet. The typical length of an on-street parking stall should be 20 feet, but may be reduced if more maneuvering area is available (as determined by the City).

**Table 3: On-Street Parking Design Criteria**

	Mixed-Use Streets	Residential Streets	Commercial /Industrial Streets
Typical Parking Stall Width	8 feet	7 feet	8 feet
Typical Parking Stall Length	20 feet	20 feet	20 feet