

Spirit Mountain RANCH

Community Wildfire Protection Plan

August 2008



Prepared by
Land Stewardship Associates, LLC
at the request of the
Spirit Mountain Ranch Property Owners Association.

Signatory Page

The following people have reviewed and approved the Spirit Mountain Ranch Community Wildfire Plan. It is now ready for implementation.

Clarence K. Morey, State District Forester,
La Veta District, Colorado State Forest Service

Date

Steve Glassey, President, Board of Directors,
Spirit Mountain Ranch Property Owners Association

Date

Colleen Williams, President, Board of Directors,
Spanish Peaks Fire Protection District

Date

TABLE of CONTENTS

I. COMMUNITY IDENTIFICATION & DESCRIPTION	5
II. COMMUNITY ASSESSMENT	8
Fuel Hazards	8
Fuel Models	9
Table 1: Fuel Models Found in Spirit Mountain Ranch	9
Chart 1: Spirit Mountain Ranch Fuel Model Coverage	10
Table 2: Spirit Mountain Ranch Fire Behavior Prediction	11
Table 3: Fire Hazard Based On Rate of Spread & Resistance to Control .	12
Community Values at Risk & Hazard Assessment	12
Values:	12
Access:	12
Risk:	13
Home Survivability and Land Owner Responsibilities:	14
Triage:	15
Evacuation:	16
Local Preparedness and Protection Capability	16
Table 4. Equipment located at Gulnare and Aguilar Fire Stations:	17
Table 5. Overview of Resources Available to SPFPD	18
Water Supply:	19
Grazing:	20
III. COMMUNITY MITIGATION PLAN	21
Survivable Space:	21
Fuel Hazard Reduction:	24
Treatment Costs:	25
Wildfire Suppression Infrastructure:	26
Turnarounds:	26
Fire Control Features/Triage Maps:	26
Uniform Street Addresses:	26
Utilizing Pond or River Water for Wildfires:	26
Evacuation Planning:	27
Strategic Recommendations:	28
Table 6: Implementation Items Priority & Cost	29
IV. IMPLEMENTATION & MONITORING	30
Implementation:	30
Monitoring:	30
Table 7: Action Plan for Completing the Spirit Mountain Ranch CWPP	31
Appendices	32
Appendix A: Maps	32
Appendix B: Fuel Model Descriptions	32
Appendix C: Fuel Hazard Reduction Guidelines	32
Appendix D: Evacuation Planning Guidelines	32
Appendix E: FireWise – A Homeowners Guide to Wildfire Retrofit	32
Appendix F: Fuelbreak Guidelines for Forested Subdivisions & Communities	32

Appendix G: Road & Driveway Specifications for Emergency Access 32
Appendix H: Spirit Mountain Ranch Triage 32
Appendix I: Subdivision Hazard Evaluation Form..... 32
Appendix J: Definition of Terms 32
Appendix K: References and Publications..... 32
Appendix L: Defensible Space Maintenance & Gambel Oak Treatment 32
Appendix M Triage Spread Sheet 32
Appendix N Spirit Mountain Ranch Open House..... 32

I. COMMUNITY IDENTIFICATION & DESCRIPTION

The Spirit Mountain Ranch (SMR) community is in Las Animas County, about 34 miles north of the Colorado/New Mexico state line and about 8 miles west of Aguilar, CO. It lies on the southeastern flank of Spanish Peaks, covers approximately 1,500 acres and ranges in elevation from 6,950 to 7,300 feet. Interstate Highway 25 provides primary access to Aguilar, County Road (CR) 43.7 to Gulnare and then CR 46 and 43.6 to the SMR. See the following vicinity map for an understanding of the ranch location.

SMR contains 43 lots (35 acre parcels) of which 27 have structures (homes or barns) on them. Access roads within the subdivision are generally 20 feet wide with a 12 foot wide gravel surface along ridge tops and broad drainages that provide year round access. Driveways are 10 to 12 feet wide, average 4 percent grade and most have good gravel surfacing. Exceptions include a 3,000 foot long driveway to Lot 31 that is not surfaced and shows evidence of rutting and difficult conditions during wet weather and a lightly used, unsurfaced access into Lot 4.

There is an active property owner's association guiding activities on the Ranch. Defensible space activities are ongoing at most locations but no evacuation planning has been accomplished.

Previous fires in the area have created a vegetative tapestry of pinyon, juniper and ponderosa pine in the over story with a rich shrub understory composed of Gambel oak and mountain mahogany. This vegetative blanket lays on a gently sloping series of ridges and drainages. Slopes range from 5 to 30 percent with an average approximating 15 percent.

Large wildfires are not unusual in the area. The Mauricio Canyon Fire located a just few miles northwest of SMR burned 4,500 acres and destroyed 5 homes in January 2006. This wind driven fire made a 5 mile run in 2 hours during extremely windy conditions. An evacuation of Spirit Mountain Ranch was attempted using a reverse 911 telephone system that failed to operate correctly. SMR residents realized the volatility of their situation and have aggressively begun preparations to protect the area from wildfire. The Morley fire burned 300 acres on Santa Fe Trails Ranch (15 miles to the south) in 1978 and was followed by Morley fires 2 & 3 in 1979 & 1980. The fire season of 2002 provided a serious wake up call to Colorado residents living in forested/wooded environs. The Crazy French (300 acres), Spring (33,000 acres) and James John (6,800 acres) fires were all in the vicinity.

Initial attack for all wildland and structure fires on Spirit Mountain Ranch is provided by the Spanish Peaks Fire Protection District Volunteer Fire Department that has stations in Aguilar and Gulnare.



Gulnare Fire Station



Augilar Fire Station

Information used in preparation of the Community Wildfire Protection Plan (CWPP) was gleaned from onsite examination, interviews with key Spirit Mountain Ranch individuals, Spanish Peaks Voluntary Department, Colorado State Forest Service, Colorado, Pioneer Natural Resources and Natural Resource Conservation Service. A public meeting was held on August 2, 2008 to review the draft CWPP and provide an opportunity for input by property owners, fire district representatives, Colorado State Forest Service (CSFS), Natural Resources Conservation Service, Division of Wildlife personnel and others who reviewed the Draft, participated in telephone conversations or attended the public meeting.

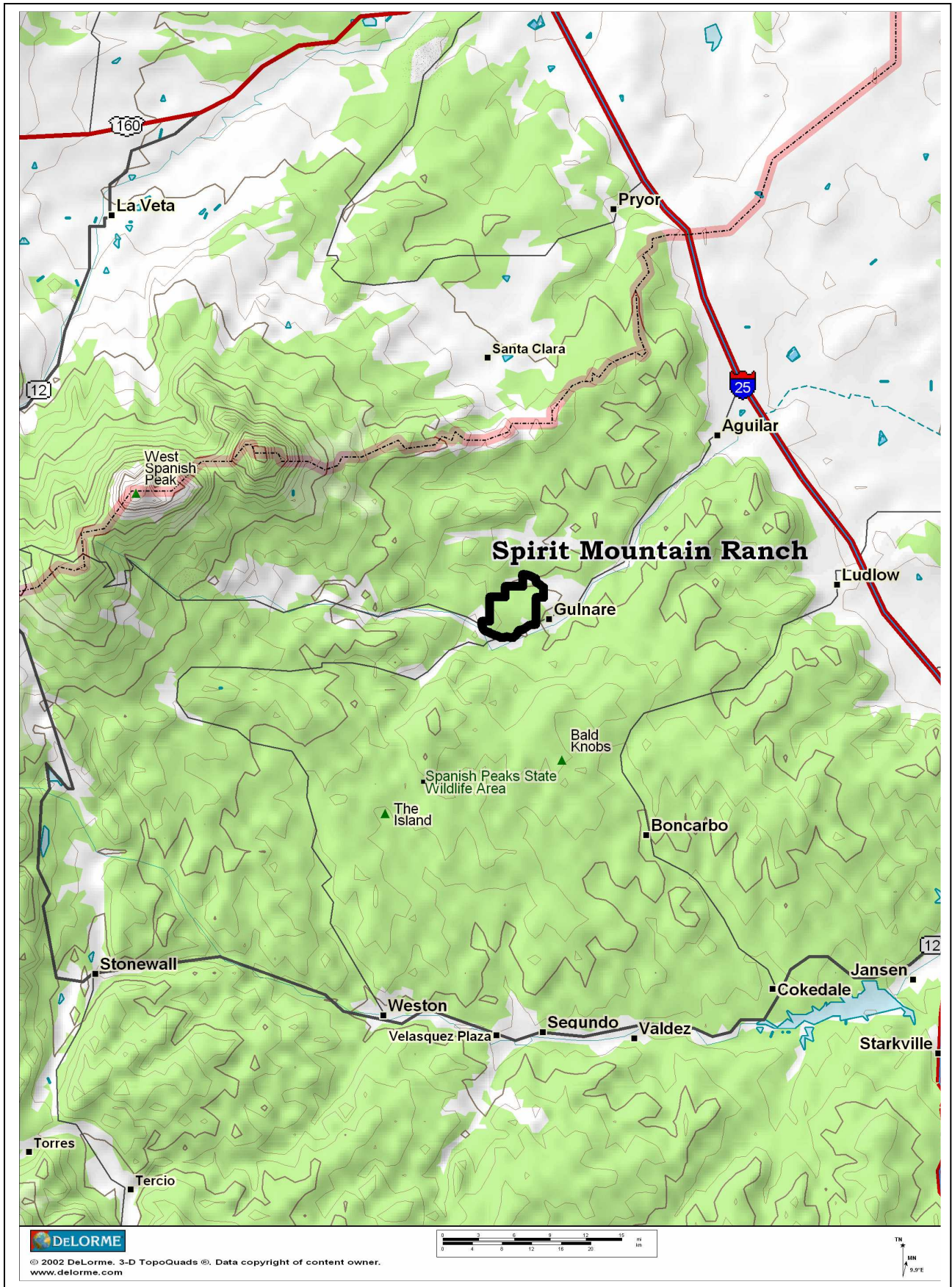

II. COMMUNITY ASSESSMENT

The overall risk to the Spirit Mountain Ranch subdivision from wildland fire is rated as MODERATE (Appendix I). This section will discuss the factors considered and contributing to the overall rating.

Fuel Hazards

Dense stands of conifer (ponderosa pine, pinyon pine and juniper) and brush (Gambel oak and mountain mahogany) cover the Ranch. Fuel ladders are abundant and will lift ground fire into the crowns of the overstory. Vegetation on north slopes tend to be dominated by ponderosa pine with an under story of Gamble oak while the dryer south slopes support a mix of pinyon and juniper with scattered occurrences of ponderosa pine. Gamble oak brush is a co-dominate fuel and is found as a major component of all the forested areas. Grassy meadows and openings ranging from a portion of an acre to 60 acres occur throughout the subdivision. Fire Behavior Fuel Models 1, 6 & 9 (Anderson 1982) are all found in various associations with one another. All but fuel models 9 have high rates of spread under relatively mild weather conditions. Table 1: Fuel Models Found in Spirit Mountain Ranch provides a brief description of these key fuel models. Where these fuel models are mixed they are shown in combination. Refer to Appendix A Maps for a map of fire hazard ratings.

All stands adjacent to structures with crown closures greater than forty percent are problematic. Continuous surface and crown fuel arrangement, both horizontal and vertical, render this area susceptible to torching, crown fire, and ignition by wind born embers, even under moderate weather conditions. The following Fire Hazard & Mitigation Map shows the severity of fire hazard for the Ranch with 97 percent rated as high fire hazard with expected flame lengths of 8 to 11 feet. This includes both the grassy meadows, stands of pinyon, juniper, Gamble oak and sometimes scattered ponderosa pines. Only 3 percent of the ranch was rated as moderate. These areas are ponderosa pine stands. None of the ranch was rated as low hazard. Table 3: Fire Hazard Based On Rate of Spread & Resistance to Control summarizes fire hazard ratings on Spirit Mountain Ranch.

Local topography and aspect further aggravates fire behavior and control. Slopes range from 5 to 30 percent with most hillsides ranging from 6 to 15 percent. While south slopes are dryer they still support heavy fuels with limbs close to the ground that serve as ladders to move fire into the crowns. Grass in the meadows and openings are not usually grazed so these areas accumulate fine fuels that can burn explosively.

Fuel Models

Fuel models are a means of describing a wide variety of combustible conditions found in a wildland environment. Thirteen (13) standardized fuel models are used in wildfire behavior prediction (Anderson, 1982). Fuel size class, fuel loading in tons/acre, fuel bed depth, and fuel continuity across a landscape are all factors that are considered when assigning a fuel model to a specific tract of land. Since it is unrealistic to expect thirteen (13) descriptions to represent the wide continuum of fuel beds found in the wild, fuel models are often combined by the percentage of an area they cover. Table 1: Fuel Models found in Spirit Mountain Ranch concisely describes fuel models in the development. Appendix A Maps includes a map of Fuel Models.

Table 1: Fuel Models Found in Spirit Mountain Ranch

Fuel Model	Description
1	Grasslands generally less than 1 foot deep
6	Shrub stands < 4 feet tall
9	Closed stands of long needled pine or hardwood stand with freshly fallen leaves

Representative photos of fuel models found on Spirit Mountain Ranch are displayed below.



Fuel Model 1



Fuel Model 9



Fuel Model 6/9



Fuel Model 6



Fuel Model 1/6

Fuel model 6 as displayed in Chart 1 Spirit Mountain Ranch Fuel Model Coverage is the most common fuel model covering 60 percent the ranch. It is characterized by dense pinyon and juniper with a significant amount of Gambel oak and mountain mahogany in the under story to act as ladder fuel.

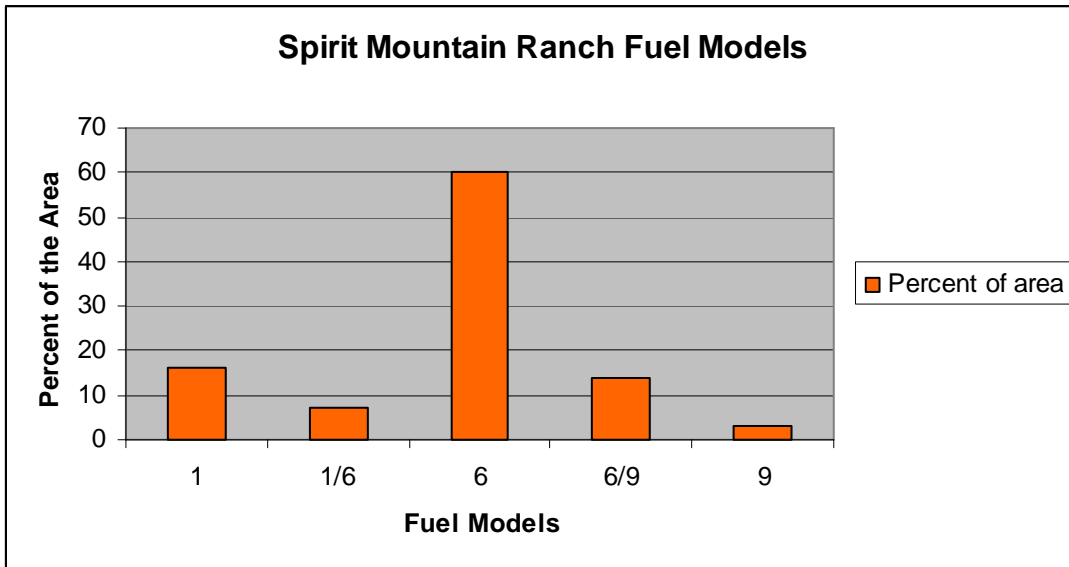

Chart 1: Spirit Mountain Ranch Fuel Model Coverage

Risk of Ignition and Wildfire Occurrence

The robust vegetative mosaic found on the ranch is living testimony to the role fire plays in ecosystem dynamics in the area. Most contemporary fires are lightning caused but human caused fires are expected to increase as more homes are built on the Ranch.

Small fires occur occasionally on the Ranch but recently a number of large fires have burned in Las Animas County. The Mauricio Fire, burned 4,500 acres a short distance northwest of the Spirit Mountain Ranch during the winter of 2006. Three major blazes burned over forty thousand acres in the Trinidad vicinity during 2002.

Low fuel moistures and low relative humidity are common in the area, as are periods of high winds. When dry and windy conditions coincide the stage is set for large, troublesome wildfires.

Fires originating in or near the community are the most immediate concern, but fires starting well beyond the boundaries of the planning area can have profound effects upon the Ranch. Rapid rates of spread and long distance spotting (starting of new fire by wind blown embers) are the norms for fires in the vicinity. The Spring fire of 2002 started in New Mexico and made an eleven mile run toward Colorado in just one afternoon. Table 2 below provides insight into potential fire behavior on a bad day at Spirit Mountain Ranch.

Table 2: Spirit Mountain Ranch Fire Behavior Prediction

Fuel model	Rate of Spread (miles/hr)	Flame length (feet)	1 hour fire size (acres)	1 hour Fire perimeter (miles)	Safety zone size (acres)
1	3.7	8	2,319	8.44	2
6	1.45	11	271	3.16	3
9	.17	4	6	0.40	0.5
1/6	3.0	11	1,469	6.71	3
6/9	.61	9	64	1.39	2

Note: Shaded zones are well beyond hand crews and engine suppression threshold.

Fire behavior predictions are based on the average weather conditions for the month of June 2002 recorded at the Bosque (a.k.a. Cuchara) Remote Automated Weather Station (RAWS) #56203. This RAWS sits at 8,174 feet elevation and is reasonably close to Spirit Mountain Ranch.

Table 3: Fire Hazard Based On Rate of Spread & Resistance to Control

Fuel Model	ROS	RTC	Hazard	% of Area	Flame Length (ft)
1	High	Low	High	16	8
6	High	High	High	60	11
9	Moderate	Moderate	Moderate	3	4
1,6	High	High	High	7	11
6,9	High	High	High	14	9

NOTE: ROS = Rate of Spread & RTC = Resistance to Control

Community Values at Risk & Hazard Assessment

Values:

Twenty seven of the 43 of the tracts on the Ranch or 63% have structures on them. The structures range from substantial permanent residences to metal buildings used for storage and barns. New homes are being built at a rate of about one a year. Twelve homes are occupied yearlong and the remainder are seasonal occupants or lots that have not had a structure built on the lot.

Ranch owners place a high premium on their natural surroundings and the visual quality of the landscape. Vast expanses of heavily burned, charred forest are objectionable whether structures burn or not. If the view is seriously eroded much of the intrinsic value of the home will also be lost.

A large, intense fire will also compromise watershed values and cause sediment and turbidity issues in the Apishapa River. Most of the sediment control structures that resemble earth ponds on the ranch would be filled with sediment. Their life for erosion control and short term water storage would be shortened.

Access:

Over four miles (4.8miles) of gravel roads are clearly signed at intersections and they provide reasonably good access to most parts of the Ranch. All but seven of the lots with structures have posted addresses at the driveway intersection. Road intersections are signed and clearly marked. It is important that all driveways leading to structures have clearly marked addresses to enable first responders to find a specific address. There are five named roads within and along the boundary of SMR that provide access around three sides of the subdivision and through it from the south to the east side.

Road grades approach a ten percent (10%) grade for short stretches on the main arterials in a couple of places and on several driveways. Spirit Mountain Place and Eagle Court are “dead end” interior roads and all “dead end” driveways longer than 100 feet should be have “No Outlet” signs at the junction with the main road. Turnarounds are available at most structures but 30% are inadequate for

fire suppression equipment. The cul-de-sac at the end of Spirit Mountain Place has a turning radius of 23 feet which is half of what is needed to turn fire equipment around.



Inadequate turn radius at the end of Spirit Mountain Place

Risk:

Three kinds of risk are associated with wildland fire. The first concern is the risk to property owners trying to evacuate under less than optimal conditions. Second is the risk to firefighters attempting to protect property. Third is the risk to the property from wildfire. The concept of survivable space addresses both the second and third facets of risk under one umbrella.

Survivable space is an area around the structures where fuels and vegetation are treated, cleared or reduced to slow the spread of wildfire towards the structure and lower the intensity of the fire as it passes the developed area. It also reduces the chances of a structure fire moving from the building to surrounding vegetation. Survivable space provides room for firefighters to do their jobs. A house is likely to withstand a wildfire if vegetation is managed to reduce a fire's intensity. Structure design and construction also influence its survivability when a wildfire passes through the neighborhood. Removing flammable materials such as fire wood, lumber and gasoline from decks and base of structures will pay big dividends when the ember storm hits the home.

Home Survivability and Land Owner Responsibilities:



Recent research into the cause for loss of homes during wildfires indicates that home ignitability, rather than wildland fuels, is the principal cause of home losses during wildland/urban interface fires. Key items are flammable roofing materials (e.g. cedar shingles) and the presence of burnable vegetation (e.g. ornamental trees, shrubs, wood piles, and pine needle accumulation) immediately adjacent to homes (Cohen, 1999).

The home ignition zone includes a home and its immediate surroundings within 100 to 150 feet of the structure. Fuel conditions within this zone, to a large degree, will determine whether a home will survive a wildfire. High intensity fire behavior beyond the home ignition zone does not transfer enough energy directly from its flames to ignite a wooden structure. The fuels surrounding a home within the home ignition zone principally determine the potential for directly igniting the home. Firebrands lofted from extreme wildfires must directly ignite on a structure to be an effective ignition source. If firebrand ignitions occur in the fuels surrounding a home, then those fuels determine the home's ignition potential. Thus, regardless of the distance firebrands travel a home's exterior materials and design and fuels in the home ignition zone determine its ignition potential from firebrands.

The primary and ultimate responsibility for home wildfire protection lies with private homeowners, not fire departments or public land management agencies (or taxpayers). It is critical that special attention be given to

removing fuels in the home ignition zone as well as preparing a defensible space around structures to improve their chances of surviving a wildfire. This includes insuring that there are no combustible materials like concentrations of pine needles, dry grass, hay or straw, firewood, deck furniture, open windows, open vents, household trash, flammable materials such as gasoline, diesel or paint thinners, paper boxes, and fabrics near the structure or in the home ignition zone for fire brands to land on. In the past few years research has found that a significant number of homes destroyed in wildfires burned as the result of the presence of combustible materials within the home ignition zone. Some homes ignited as long as eight hours after the fire front passed.

Triage:

Structure triage was conducted on each tract with buildings on it. Triage is a concise decision making process that is used if/when a wildfire threatens multiple structures simultaneously. See Appendix H: Structure Triage for a brief description of the triage process. See Appendix A : Triage and Fire Control Features Map for a fold out map that shows the results of the Spirit Mountain Ranch Structure Triage and Fire Control Features. Appendix M SMR Triage contains a spreadsheet summarizing data collected during field data collection. The following observations are gleaned from the site visits.

- ✓ Only 56 per cent of the structures were rated as being able to survive a wildfire if fire control resources were not available. Under extreme conditions the survival rate would probably be even lower. That leaves 44 percent of the structures within the Ranch that were rated as not being able to survive a wildfire without fire suppression efforts. This “*survivability*” rating is a summary of all the factors listed below.
 - Only 70 per cent of the lots had adequate space to turn fire control apparatus around. 30 percent has a marginal or no turn around for fire equipment at the structure.
 - A safety zone was immediately available at 82 per cent of the structures.
 - 89% of the driveways were in good enough condition to be considered adequate escape routes for firefighting resources.
 - 57 per cent of the tracts have good survivable space, while another 23 per cent are fair and the remaining 20 per cent are poor.
 - One of the most serious problems observed during triage was structures (primarily homes) sitting at the top of a slope with heavy fuels below the structure.

It is important to understand the role of triage in this community wildfire protection plan. It is a quick, inexpensive way to determine overall community wildfire risk and helps to identify areas to focus improvement efforts. Its utility during an actual wildfire depends upon the nature of the wildfire. When only one structure is threatened firefighting resources are usually assigned to protect that single structure, unless it is a death trap and totally undefendable. During a large wildfire scenario when more structures are threatened than there are firefighting resources to protect them, this triage work will help the Incident Commander assign scarce resources to the places where they have the best chance for success.

Maps developed for this Community Wildfire Protection Plan identify structure location and survivability. The CWPP is an ever evolving document and will be revised on a regular basis to reflect new information about structure survivability and other important fire control features on the Ranch.

Evacuation:

To date, an Evacuation Plan does not exist for Spirit Mountain Ranch. Appendix D contains a discussion on Evacuation Planning and includes essential elements that need to be included in the planning but it must be a collaborative effort with land owner involvement. There are several potential evacuation routes out of the Ranch. Spirit Mountain Drive provides good access through the ranch from its intersection with CR 46 (the main entrance road on the south side) to the back entrance off CR 43.6. A potential way out on the west side could be provided by the old Spirit Mountain Road that exits the SMR about ¼ mile west of the intersection of Spirit Mountain Drive and Eagle Court and intersects with the new gas well road immediately west of SMR. This old road has been abandoned for some time and is not being maintained. However, written permission from the land owner to use this route in an emergency would be needed before it could be used. Trees would need to be cleared and the considerable “rebuilding” would be necessary before passenger cars could use the route.

Local Preparedness and Protection Capability

Spanish Peaks Fire Protection District (SPFPD), has a cadre of 17 volunteers. All but one (medical skills) are wildland qualified and capable of building fireline with hand tools for an extended period of time. Table 4 Equipment located at Gulnare and Aguilar Fire Stations provides detailed information on specific types and location of fire equipment while resources available to the SPFPD are summarized in Table 5 Overview of Resources Available to SPFPD.

Table 4. Equipment located at Gulnare and Aguilar Fire Stations:

Equipment	Category	Type	Station
<u>Engine #1</u> (CSFS) 6X6 2 ½ Ton 1969 American General Diesel-860 Gal. Diesel pump	Brush CAFS	Type 3	Gulnare
<u>Engine #2</u> (CSFS) 5/4 1967 Kaiser Jeep 4X4 gas engine-200 gal. S/N 34769	Brush CAFS	Type 6	Gulnare
<u>Engine #3</u> 1948 Ford 2 ½ Ton—8.2 Diesel—750 Gal.	Structure	Type 2	Aguilar
<u>Engine #4</u> 2000 Ford F-350—1Ton--4X4 Diesel 250 Gal W/Foam	Brush	Type 6	Aguilar
<u>Engine #6</u> 1980 Dodge 1 Ton 4X4 Seagraves model W400-490-360—350 Gal	Brush	Type 6	Gulnare
<u>Engine #7</u> 6X6 - 1000 Gal—gas engine— w/o tools	Brush/Tender	Type 5	Aguilar
<u>Engine #8</u> 1993 Freightliner—3300 Gal w/porta-tank w/direct double feed capability	Tender	Type 2	Gulnare
<u>Engine #9</u> Ford 350 Diesel 4X4 350 Gal w/foam w/SCBA's sidewinder and spray bars	Brush	Type 6	Aguilar
<u>Engine #10</u> 2008 Ford 550 Diesel 4X4,350 Gal w/foam,mini-pumper w/SCBA's sidewinder nozzel,ladder	Brush/Structure	Type 6	Gulnare
<u>Engine #12</u> 1978 Pierce 1000 Gal 1200 LF 2 ½ " and 600 LF 1 ½ hose deck gun,w/ladders	Structure	Type 1	Aguilar
<u>Engine 0.5</u> 2006 Honda Rubicon ATV, 4X4,25 Gal tank-pumpspray unit with trailer, 4—5 Gal backpacks tool basket, winch,capable of search & rescue			Aguilar
<u>Unit 5</u> Chev, gas, 4X4 8 passenger comand vehicle capable of towing ATV trailer			Aguilar

Table 5. Overview of Resources Available to SPFPD

Resource	Number Available	Additional Resources Needed
Total Volunteers	17	
Wildland Qualified	14	
Brush Truck Type 6	5	1
Water Tender Type 2-- 3300 gal	1	
Water Tender Type 5-- 1000 gal	2	
Water Tender Type 3-- 860 gal	1	
Water Tender Type 2-- 750 gal	1	
Water Tender Type 6-- 350 gal	4	
Structure Truck Type 1-- 1000 gal	1	
Brush Truck Type 6--200 gal	1	
Portable Pump	1	
Fire Tools—3 tools per engine	11	
Fire Tool Cache	0	
Hand Held Radio	18	
Fire shelters	4	11
Coveralls and helmets for equipment operators		2
Wildland training		
S290 5 @ \$50		5
S130/190 5 @ \$285		5
Sawyer class S212 4 @ \$470		4
S211 4 @ \$285		4
S215 4 @ \$285		4
Cisterns for fire control on Spirit Mountain Ranch	2	Replace draft pipe with straight pipe on one
Engine 4 Spray bars		1
Mini-pumper		1

The Gulnare Fire Station is located within one mile of SMR and is immediately available. Equipment at Aguilar is probably 15 minutes from the SMR entrance and as much as 20 minutes to the scene depending on the location on the Ranch.

Additional reinforcements from Fischer Peak FPD and additional equipment and manpower from nearby departments (Hoehne, Stonewall, Cokedale, Walsenburg, Santa Fe Trail Ranch and Trinidad) that have mutual aid agreements with SPFPD are an hour or so out with availability dependent upon workload at the time of the request."

Water Supply:

Two 1,500 gallon cisterns to provide water for fire control purposes exist on the Ranch. These cisterns provide quick access to water for fire control in the event of a fire on the Ranch. One is located at the intersection of County Road 46 and the driveway for Lot 28 and the other is located at the intersection of Spirit Mountain Drive and Eagle Court. The 45 degree bend in the fill neck makes it difficult for engines that are equipped with a 3 inch PVC stinger to draft water. The cistern at Eagle Court and Spirit Mountain Drive needs to be modified to allow engines easier access for drafting water. Another source of water for fire control is a spring fed pond on the Dulcevie Ranch. Additional water sources are needed.



Fire Control Cistern

Residents in Spirit Mountain Ranch, for the most part, get their water from wells on their property. Well capacity and depth varies considerably with location on the ranch. One well on the southern edge of SMR near the Apishapa River (Lot 21) is reported to be capable of producing 11 gallons per minute while others at higher elevations are capable of 2 gallons per

minute or less. The owner of Lot 21 indicated some interest in cooperating with the fire department to install a fire cistern for fire control purposes that could be filled with this well. Several residents haul water and maintain cisterns while another is contemplating drilling over 1,000 feet in an attempt to get water. Some home owners haul their domestic water as not all have access to wells.

SMR was a working cattle ranch in the past and has a number of earthen erosion control structures that catch runoff water and snow melt in the drainages. These reservoirs usually dry up and are not reliable sources of water for wildfire control. The Apishapa River on the southern boundary of the Ranch is a reliable source of water for the FPD. There are a number of locations where a pump can be placed in the river to fill engines or tankers for fire control efforts; none are developed for that use. Mitotes Lake, locally known as Huffman's Pond, is located north of the SMR off CR 43.6 and is considered a potential source of water. Other potential sources include water pits at nearby gas wells where water is being pumped and removed to facilitate the production of methane.

Potentially, water is available at the methane gas well sites; however it must be tested to assure that the methane levels are safe for use for fire control purposes. Specific permission from Pioneer Natural Resources would be required before water from gas wells could be considered. A new water line is being planned to remove water from these well sites. It is possible that hydrants or draft points could be negotiated to provide water for local fire control efforts if residual methane levels are low enough to be safe.

Grazing:

SMR was a working cattle ranch in the past and it continues to encourage livestock grazing at conservative levels. The shortages of livestock watering facilities make it difficult for livestock to graze in the area. The grazing cattle help keep the grasses and other fine fuels from accumulating in the open areas of the ranch. A carefully managed program to provide livestock drinking water at key locations could be a valuable asset in managing fine fuels that have the potential to rapidly carry a fire into the ladder fuels that are prominent in vegetation dominated by pinyon, juniper and Gambel oak brush which has significant ladder fuels capable of elevating a wildfire into the crowns.

III. COMMUNITY MITIGATION PLAN

The following mitigation plan was developed based on the Core Team's knowledge of the wildland fire issues in the FPD and in consultation with interested parties during the August 2nd Open House in Gulnare. Appendix N Spirit Mountain Ranch Open House includes details of the meeting and a summary of the issues and concerns discussed at the open house. Most of the discussion related to potential sources of grant money that might be available for wildfire mitigation. Colorado State Forest Service plays a central role in the grant application process and they provided much valuable information. It was clear that the subdivision needs to develop grant writing skills and learn the process in order to capitalize on the financial assistance that is available. The Draft was modified to include information presented at the meeting.

Responses to the questionnaire indicate that participants in the Open House knew that they owned property and lived in an area that was vulnerable to wildfire. All respondents felt their structures would survive a wildfire and all were familiar with survivable space concepts. Most (83%) indicated a willingness to expend labor and money to improve structure survivability and most (83%) were interested in applying for a grant to defray some of the expense. Most of the respondents (83%) would like additional information on structure survivability. "On site" consultations was the most popular format desired (67%) while formal workshops and brochures were also desired. Concerns listed were that a wildfire might really occur, brush control was difficult, absentee owners do not do adequate mitigation and that there was inadequate fire protection manpower. Suggestions included; getting the county government involved, getting help chipping brush and applying chemical herbicides, outreach to absentee owners and making home owners accountable for fire livable space.

A summary of responses to the questionnaire that attendees completed is also included in Appendix N.

Survivable Space:

Effective survivable space is one of the landowners' most reliable means of providing wildfire protection for their structures. Mountainous terrain, heavy fuels, and complex landownership patterns on the Ranch make landscape level fuel modification very difficult. This plan suggests a 300 foot wide shaded fuel break along the primary road system in the Ranch but **the key to individual structure survival is Defensible Space and good "Fire Wise" practices.**

During periods of high to extreme fire danger a wildfire will rapidly exceed the suppression capability of the local fire suppression forces. Table 2: Spirit Mountain Ranch Fire Behavior Prediction displays the difficult position

firefighters will face on a dry, windy day. Hand crews can be effective when flame lengths are less than four feet. On a bad day only three percent of the Ranch is expected to have fire of this intensity. The rest of the area will experience flame lengths from eight to 11 feet. The size of a fire within the first hour is also expected to grow beyond local initial attack capability over ninety percent (97%) of the ranch.

Homeowners should not expect much protection intervention if/when a large fire burns on or through the Ranch. The harsh realities of triage, evacuation and coordinating attack with mutual aid forces will consume local fire forces for several hours.

State Tax Incentives for Wildfire Hazard Mitigation:

House Bill 1110 created a five year program from 2009 to 2014 that allows landowners to deduct the actual costs of their wildfire mitigation, up to \$2,500 from their state income tax. The program allows each landowner to get credit for fifty percent of the cost of wildfire mitigation up to a total of \$2,500. To get the full credit the total mitigation costs must be \$5,000 or greater. The work must be done in accord with an existing Community Wildfire Protection Plan to qualify.

Colorado State forest Service will be administering the program and verifying the actual work completed. This is a good incentive for individual landowners to improve survivable space around their structures. They can get their personal labor recognized at decent hourly rates.

Fire Wise rated defensible space is the key to structures surviving on their own. Do it now and keep it maintained.

In many cases sizeable effort has been spent developing defensible space around quality homes perched on the edge of a steep slope with heavy vegetation below the structure. Unfortunately the trajectory of the flames will intersect the structure, exposing it to direct contact with the fire. During site visits for triage, several landowners acknowledged the paradox they have created with the location of their home.



Heavy fuel on slope below this structure make it unlikely that the structure will survive a wildfire

The POA will encourage people to set new homes back from the edge of steep, brushy slopes using the guidelines provided in “Creating Wildfire Defensible Space Zones, Circular #6.302 (Dennis, 2003) Owners of existing homes in this situation should be encouraged to thin the fuels on the slope below the structure so that crown cover does not exceed 40

percent and remove all debris and ladder fuels that could carry the fire into the tree canopy. Chart 2: Slope Impact on Defensible Space demonstrates the effects that slope have on the needed width of Defensible Space. As slope percentage increases on slopes below structures the distance from the structure to the edge of the treated area increases at an accelerated rate.

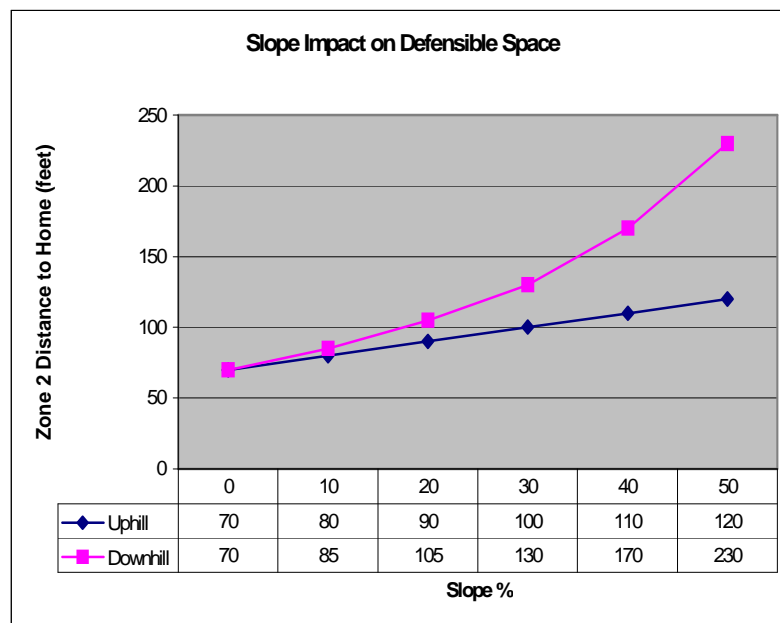

Chart 2: Slope Impact on Defensible Space

Fuel Hazard Reduction:

One of the best ways to reduce structure loss in the wildland urban interface is to avoid placing structures in close proximity to flammable vegetation. The other option is to reduce the intensity of wildfires that will burn through areas surrounding structures. Much of this responsibility falls on the homeowner. However, crown and spot fires have a way of neutralizing well intended, limited scale, fuel reduction projects. A well tended forest a half mile from a structure may reduce the intensity of a fast moving wildfire but it will not significantly improve survivability of structures in developments that have not completed their own fire hazard reduction work.

The Fire Hazard and Mitigation Map in Appendix A Maps includes a proposed fuel break with treatments to thin fuels along the primary roads in SMR. Land owners need to reduce fuel hazards around their property and driveway. Priorities for reducing fuel hazards should be based on the following criteria:

- *Priority 1:* Protection of structures; survivable space around structures and areas adjacent to communities.
- *Priority 2:* Thin or mow fuels along roads for evacuation and firefighter ingress and egress.
- *Priority 3:* Thin all ponderosa pine areas so that crown cover does not exceed 40 per cent.

Primary roads on SMR run along ridges or in broad grassy drainages that provide marginal opportunities for firefighters to make a stand against an aggressive fast moving fire. Their utility as fire control features can be improved substantially by thinning both sides of the road. Road rights of ways (ROW) extend thirty (30) feet each side of the center line. A sixty (60) foot wide break is a start towards an adequate break in fuel continuity but is not sufficient to provide the kind of safety needed in the heavy fuels found on the Ranch; however it is a starting place and should be accomplished as a high priority. Thinning to get a three hundred (300) foot wide break will require negotiations with and commitment from adjacent landowners. It is critical that the fuelbreaks be continuous. Without wide spread individual landowner cooperation, creating effective fuelbreaks is not feasible.

This shaded fuel break program along the primary roads would be 3.4 miles in length and would cover 124 acres. At a cost of \$500 per acre to thin using a hydro ax, the estimated cost would be about \$62,000. It will be complex to negotiate because it runs along the boundary of most of the lots in the SMR. It improves fire control opportunities through the center of the ranch and begins to

break up hazardous fuel continuity. In addition to running down the main ridge

top these roads pass through and link the major grassy meadows on the SMR.



Shaded fuel break in pinon-juniper near Crestone

An alternative would be to work within the sixty (60) foot total right of way along the roads. The entire 3.4 miles of road in the Ranch could be thinned within the ROW (approximately 25 acres) for about \$13,000. This would provide a good place for fire personnel to burn out or backfire as needed, but this approach

does not afford much protection during more volatile fire conditions.

Fuelbreak Maintenance:

Gamble oak is an abundant under story species on the Ranch. It sprouts vigorously after being cut. Keeping gamble oak under control following thinning will be a task. Two methods are effective to keep them in check. Mowing is

effective but has to be done on an annual basis. Herbicide treatment is also effective but may be objectionable to some landowners. See Appendix L: Defensible Space Maintenance & Gambel Oak for a further discussion on herbicide control of Gambel oak. A new product, Garlon 3A, put out by Dow AgroScience has been used with considerable success to control Gambel oak in the area .



Shaded fuel break in ponderosa pine between Santa Fe Trails Ranch and Vermejo Ranch

Treatment Costs:

Treatment costs for defensible space and shaded fuelbreak work are highly variable depending on the amount of thinning and slash disposal to be done and the relative care involved in doing the work. Hand crews working next to structures and chipping the slash will cost from \$1,000 to \$2,000 per acre.

Mechanical thinning with a hydro-ax type machine will normally cost from \$400 to \$600 per acre depending on tree density, slope and rockiness.

Wildfire Suppression Infrastructure:

Turnarounds:

Most driveways provide adequate room to turn fire equipment around at the structure. The turning radius at the cul de sac on Spirit Mountain Place is less than 25 feet which is inadequate for turning fire equipment around. There is no turnaround available at the newly constructed structure on Lot 31.

Accommodations for turning vehicles around near the end of the road are critical for fire suppression purposes

Fire Control Features/Triage Maps:

The maps developed for this Community Wildfire Protection Plan provide valuable information for wildland fire fighting (See Appendix A Maps). While the firefighters from the Gulnare and Aguilar Stations may know the Ranch like the back of their hands, reinforcements and mutual aid folks will struggle with the road layout and fire suppression opportunities. Communications can be enhanced by providing high quality maps that show important features.

Spirit Mountain Ranch POA should provide a set of laminated maps and orthophotos to dispatchers, first responders, the Sheriff's department and Colorado State Forest Service. They will also have a few reserved to distribute during the inevitable emergency.

Uniform Street Addresses:

Universal, visible, street addresses are absolutely imperative for first responder effectiveness. Las Animas County is the single entity assigning addresses. However, not all home owners have posted their address at the driveway and on the structure. The POA should require implementation of their standardized approach to addressing driveways. While 74 percent of the lots with structures have a clearly signed address on the driveways, there are 7 lots with structures that do not have posted addresses and none of the driveways are marked with reflective signs. Property owners that have driveways without addresses at the intersection with the primary road should be encouraged to comply. Reflective, non-combustible address signs should be acquired and posted at all driveway intersections.

Utilizing Pond or River Water for Wildfires:

Getting fire equipment close enough to the water source to draft and fill engines and tankers may be problematic due to drafting capability of individual pieces of equipment. The most reliable method to fill engines and tankers is with mechanical high volume or high pressure pumps. The most flexible system to transfer pond water to fire trucks is the "Floto-Pump". This light weight pump

can be carried by one person and is simple to operate. You merely connect a hose to the pump, place it in the pond and start it. The pump floats on the pond and primes itself. The pump can also be placed in a large folding tank to provide high pressure water while an engine shuttles water from the closest water source.

The addition of a dry hydrant on the Apishapa River would provide a valuable and reliable source of water for firefighting, especially in winter months when ice on the ponds may make their use with Floto-pumps difficult. While properly installed dry hydrants are an asset to fire control efforts; an improperly installed dry hydrant will require considerable maintenance keeping debris clear of the intake.

A drafting site with a good parking area at Mitotes Lake (locally known as Huffman's Pond) that would allow fire control equipment to get close enough to use a Floto pump to load water should be explored and constructed if permission can be obtained from the land owner. This site has been used in the past and has good potential.

Construction of an additional cistern linked to a good well to provide additional water for fire control would augment the water supply that is currently available. It is suggested that negotiations be entered with the owner of lot 21 who has a well capable of producing approximately 11 gallons per minute to construct a cistern that could be available for fire control purposes. This land owner has indicated an interest in working out something to improve the supply of water for fire control purposes.

The Fire Control Cistern located at the intersection of Spirit Mountain Drive and Eagle Court has a 45 degree bend in the fill neck that makes it difficult for fire engines to draft water to. The 45 degree angle should be removed so that engines can more easily draft water from the cistern.

Evacuation Planning:

Evacuation planning is needed to minimize fire emergency confusion and risk to residents who might be asked to evacuate in the event of an emergency. Appendix D provides guidelines for developing an evacuation plan and the Fire Hazard and Mitigation map in Appendix A includes suggestions for the location of evacuation routes and other fire control features including safety zones.

In many cases sheltering in place may be a better option than attempting to notify and evacuate the occupants of sparsely developed, large subdivisions like Spirit Mountain Ranch. Sheltering in place is the norm in Australia where fire spread rates compromise evacuation procedures. Australians converted from evacuations to sheltering in place because they were not able to safely notify and remove residents from the large areas covered by wildfire. Once a family realizes their best option for surviving a wildfire is staying home they look at their property differently. To shelter in place one must have a good safety zone around their

home and a very fire resistant structure. Fire shutters and cisterns are the norm. Once the flaming front passes the occupants can go outside and take action on any smoldering embers near the structure. Sheltering in place is an alternative to evacuation that needs to be considered for areas where notification of occupants is time consuming and fire spread rates are high.

One factor to consider and perhaps address directly in the Evacuation Plan is the amount of time it will take to implement fully in comparison to the expected fire behavior described in Table 2: Spirit Mountain Ranch Fire Behavior Prediction. Fire spread rates of two to almost three miles per hour and spotting distances of close to a half a mile mean that evacuations should probably be implemented when any fire is moving toward the ranch and is within six or seven miles of the Ranch.

During the Mauricio Canyon Fire in 2006 the county's reverse 911 system was used and it failed to function as planned. As a result residents in SMR have set up an informal calling tree so that they can assure that everyone is notified of the danger. Another factor to consider is the formalization of back-up plans when key individuals in the area calling trees are unavailable.

An evacuation simulation exercise would be useful for Ranch residents and should be scheduled following completion of the evacuation plan. This test run will give everyone involved a better sense of the task at hand.

The old Spirit Mountain Road which goes west from the intersection of Eagle Court and Spirit Mountain Drive in the northwest portion of the Ranch could provide an additional evacuation route to the northwest if permission could be negotiated with the land owner. This road has been abandoned for years and would need extensive work to repair erosion damage and to clear trees from the old road way. Currently the gate on the ranch boundary is locked.

Strategic Recommendations:

The Spirit Mountain Ranch has committed residents who are concerned about their vulnerability to wildfire but there is no full time focus in pre-planning, hazard detection, follow up, communications, coordination, and/or implementation of improvements. The community does not have a mechanism for administering multiple demands, setting priorities, and insuring representation that benefits the community as a whole.

In order to strengthen the ability for SMR to implement the Community Wildfire Protection Plan funding should be sought for a shared coordinator or project manager to assist with implementation of the Plan, including the required overall leadership, management, and activity coordination. In addition the position should be responsible for such items as overseeing management of defensible spaces in the community and generation of grants for the implementation of the

Community Wildfire Protection Plan with the Colorado State Forest Service. This position should be shared with other subdivisions that have similar problems.

Table 6: Implementation Items Priority & Cost

Mitigation Action	Priority	estimated Cost (\$s)
Implement Universal Street Addressing System including reflective signs for all driveways.	1	1,500
Defensible Space Around All Structures (11 rated as poor or fair @ \$3,000/lot)	2	33,000
Laminated Triage Maps (20 sets)	3	1,000
Waterous Floto Pumps to access river water (2 pumps @ \$2,500)	4	5,000
Negotiate and document rights to use pond, river water or well water for firefighting and for alternate evacuation routes	5	1,000
Evacuation Plan Preparation	6	1,000
Evacuation Simulation	7	1,000
Funds for shared Project Manager or Coordinator	8	5,000
Prioritize & Construct Turnaround on Spirit Mountain Place Cul de Sac	9	10,000
Spirit Mountain Ranch Roads Fuel Break (3.4 mi=124 ac @ \$500 per ac)	10	62,000
Dry Hydrant near Asphapa River	11	3,000
Cystern for Fire Control Water	12	5,000
Fuel Break Maintenance (\$5,000 per year)	13	ongoing
Total		128,500

IV. IMPLEMENTATION & MONITORING

Implementation:

Table 6: Implementation Items Priority & Cost lists the mitigation actions/projects identified in this CWPP. There are 11 homes that would probably not survive a wildfire. Home owners need to take actions to improve their defensible space so that the structures are survivable and that fire fighters have safe ingress and egress.

Table 7: Action Plan for Completing the Spirit Mountain Ranch CWPP identifies the responsibilities and tasks necessary to accomplish the job at hand.

Monitoring:

Monitoring progress is a crucial part of seeing any plan through to completion. Given the values at risk at SMR it will be important to take a pulse on accomplishments on an annual basis. We expect more homes to become survivable and maps will have to be revised to reflect the work that has been accomplished. The POA will revisit the CWPP and associated accomplishments each fall and will get new maps printed as accomplishments warrant.

Through the Colorado State Forest Service seek funds for the purpose of cost-sharing (with another subdivision or the county) a coordinator (implementation manager) who, among other things, would do the following:

- Provide the leadership needed to implement this plan.
- Provide guidance and direct assistance in preparing grant applications
- Establish a prevention attitude in the community for wildfire.
- Strengthen public understanding, acceptance and participation in SPFPD operations and improvement projects.
- Insure follow up to commitments by the community or within the community and on behalf of the SPFPD goals.
- Facilitate the organization of an ongoing cooperative management team consisting of members from the SMR POA Board of Directors, SPFPD Board of directors and Las Animas County officials. This group will act as an advisory board to represent the community as a whole. This entity would do the following: set priorities, develop and administer fund raising activities, interact with and coordinate with County, coordinate with State and Federal agencies on behalf of the community as a whole, and insure follow up on all operations and or activities.

Table 7: Action Plan for Completing the Spirit Mountain Ranch CWPP

Mitigation Action	Target Date	Assigned to	Completed ✓
Continue to Implement Universal Street Addressing System and reflective signs	12/1/2008	POA & SPFPD	
Defensible Space Around All Structures	Ongoing -- complete by 2010	POA	
Shared Project Manager or Coordinator	9/1/2009	POA	
Laminated Triage Maps (20 sets)	3/1/2009	POA	
Waterous Floto Pumps and/or dry hydrants to access pond and river water	5/1/2009	POA & SPFPD	
Negotiate and document rights to use pond, river and well water for firefighting and evacuation routes	5/1/2009	POA & SPFPD	
Evacuation Plan Preparation	4/15/2009	POA	
Evacuation Simulation	7/1/2009	POA	
Constructing Turnaround on Spirit Mountain Place Cul de Sac	2010	POA	
Complete Spirit Mountain Ranch Road Fuel Break	7/1/2011	POA	
Fuel Break Maintenance	Ongoing	POA	
Installation of cistern for fire suppression	7/1/2010	POA & SPFPD	
Installation of dry hydrant	5/31/2009	POA & SPFPD	

Appendices

Appendix A: Maps

Appendix B: Fuel Model Descriptions

Appendix C: Fuel Hazard Reduction Guidelines

Appendix D: Evacuation Planning Guidelines

Appendix E: FireWise – A Homeowners Guide to Wildfire Retrofit

Appendix F: Fuelbreak Guidelines for Forested Subdivisions & Communities

Appendix G: Road & Driveway Specifications for Emergency Access

Appendix H: Spirit Mountain Ranch Triage

Appendix I: Subdivision Hazard Evaluation Form

Appendix J: Definition of Terms

Appendix K: References and Publications

Appendix L: Defensible Space Maintenance & Gambel Oak Treatment

Appendix M Triage Spread Sheet

Appendix N Spirit Mountain Ranch Open House

APPENDIX A – Maps

Fire Hazard and Mitigation-Spirit Mountain Ranch

Fuel Model- Spirit Mountain Ranch

Triage and Fire Control Features- Spirit Mountain Ranch

APPENDIX B – Fuel Model Descriptions

The primary fuels within the Spirit Mountain Ranch) are forested land and grasslands. The area is dominated by pinyon pine forest and ponderosa pine stands along the foothills of the Spanish Peaks. Ponderosa pine occurs in scattered stands and as a minor part of most of the pinyon pine stands. Both have a substantial amount of Gamble oak brush in the under story. These conifer forests are generally dense enough to sustain a substantial crown fire resulting in a high fire risk. In addition to the fuel models described below these fuel models also occur as a mix of fuel models.

Fuel Model 1

Fire spread is governed by the fine, very porous, and continuous herbaceous fuels that have cured or are nearly cured. Fires are surface fires that move rapidly through the cured grass and associated material. Very little shrub and timber is present, generally less than one third of the area.

Fuel Model 6

Fire spread is primarily through dense shrubs with juniper and pinyon pine that ranges in height from 6 to 15 feet. There are occasional pockets of debris distributed throughout the unit. Fires require moderate winds, greater than 8 mph at mid flame height. Fire will drop to the ground at low wind speeds, if there is no ground slash, or at openings in the stand.

Fuel Model 9

Fires run through the surface litter faster than model 8 and have longer flame height. Concentrations of dead-down woody material will contribute to possible torching out of trees, spotting and crowning. The pure stands of aspen represent this model. In the fall, after the associated grass and forbs have cured, this fuel will burn more intensely and is temporarily more of a threat.

APPENDIX C – Fuel Hazard Reduction Guidelines

MINIMUM TREE SPACING – RULE OF THUMB ***Strive to reduce crown density to 40% or less.***

Ponderosa Pine/Douglas Fir: Convert stem diameter from inches to feet and add 7 more feet.

Example: A Ponderosa Pine 8” in diameter at DBH will have a spacing of 8 feet plus 7 feet for a total of 15 feet to the next tree.

Tree spacing does not necessarily need to be even. In fact, the fuel treatment area will look more natural if the spacing varies and small clearings are intermingled with small groups of trees. The important focus should be on breaking up fuel continuity – both horizontally and vertically.

If trees are very tall in relationship to their diameters, implement the thinning work over a long enough time to allow the standing trees to develop their wind firmness and resistance to snow bend. Thinning when trees are small helps reduce prevent these vulnerabilities. Thinning in patches and designing the thinning to minimize wind effect can be done depending on location. All of these can be used but can best be accomplished with the assistance of an experienced forester.

An important part of fuel hazard reduction is removal of the ladder fuels; particularly when adequate thinning cannot be accomplished. Therefore, the following is important to do within a timber canopy.

- ✓ Prune trees to 6 or 10 feet above the ground, depending on slope, leaving at least 1/3 live tree crown
- ✓ Remove tree reproduction from under the canopies of remaining trees
- ✓ Remove sagebrush, oak or any other flammable brush from under the canopies of remaining trees. Reduce the size and height of remaining clumps of brush
- ✓ Remove all dead forest debris within defensible space and fuelbreak areas.
- ✓ Reduce concentrations of dead forest debris within other areas
- ✓ Remove trees recently killed by mountain pine beetle* or other disturbances within defensible space and fuelbreak areas.

- ✓ Reduce numbers of trees recently killed by mountain pine beetle* or other disturbances in other areas. Only 1 to 3 dead trees per acre are needed for wildlife habitat purposes

**Note: Proper slash disposal procedures should be implemented to avoid attracting Mountain Pine or other bark beetles to the project area.*

APPENDIX D – Evacuation Planning Guidelines

Background

The growth of urban development in forested wildland areas in recent years has resulted in a potentially hazardous situation. People are attracted to forested areas seeking solitude and to escape the pressures of everyday life. Large land holdings have been subdivided into small, affordable acreages for cabin sites or remote homes. The new generation of small lot landowners value individual trees and have often built their cabins under the cover of or within these overstocked forests. Cabins are constructed on prominent points or ridge tops for the view or they are tucked into the forest canopy seeking solitude. In order to minimize the impact of their presence on the land driveways are often narrow with inadequate opportunities to turn around at the building site. At the same time, wildfires have been aggressively suppressed allowing dead fuels to accumulate to alarming levels and young trees to establish in high densities. These ladder fuels provide a “leg up” for a wildfire to burn into the tree crowns and move rapidly under windy conditions. Little attention has been paid by landowners to the potential destructive capacity of an uncontrolled wildfire.

In an emergency wildfire situation that threatens the lives and property of residents in the area, (Spirit Mountain Ranch), in consultation with the county sheriffs, fire suppression teams and land managing agencies may recommend that residents evacuate to a safe area. Prior evacuation planning is essential to implement this action effectively.

By definition, evacuation is a protective action—moving people from a place of danger to a place of relative safety. It is a temporary mass movement of people that collectively emerges in coping with threats to area residents and visitors.

An Evacuation Plan will facilitate the orderly evacuation during an emergency wildfire situation. Step by step actions provide critical information and guidance for fire suppression and law enforcement personnel during an emergency situation. Each subdivision, home site development area or land owner association should be strongly encouraged to develop an evacuation plan for their area that identifies potential evacuation routes and critical information (locked gates, inadequate bridges, etc) for a variety of wildfire threat scenarios.

Critical Contacts

Las Animas County Sheriff	719-846-2211
Las Animas County Emergency Manager	719-846-6886
Colorado State Patrol	719-846-2227
Colorado State Forest Service	719-742-3588
Colorado Division of Wildlife	719-680-1410
San Carlos Ranger District, Pike & San Isabel NF	719-269-8500
Pueblo Interagency Fire Center	719-553-1600
Federal Emergency Management Agency	303-235-4900
Local News Media KCSJ 590 AM Radio	970-641-4000
Red Cross Weston	719-868-2024
Local Towing Services Trinidad	719-846-7273

Check List When Potential for Evacuation Exists

- 1) Close back country roads and trails at trail heads
- 2) Post on bulletin boards information regarding fire danger
- 3) Set up a local Information Center where residents and visitors can access up-to-date information and status regarding wildfires that pose a threat to the area
- 4) Provide routine updates on wildfire conditions for local radio and television stations as the threat increases
- 5) When the fire suppression team and land managing agencies (US Forest Service, BLM and Colorado State Forest Service) believe evacuation may become necessary, notify the Las Animas County Sheriff and County Emergency Manager
- 6) Fire suppression team and land managing agency managers should meet and coordinate with the Sheriff and County Emergency Manager to decide if an evacuation is necessary. The decision to evacuate should be made and implemented well before the evacuation needs to be complete. Local conditions and the fire's rate of advance will dictate timing and trigger points
- 7) The Sheriff, after consultation with the land managing agencies and County Emergency Manager makes the decision to evacuate the threatened area and implements the actual evacuation
- 8) Notify residents and visitors of the Order to Evacuate
 - Law enforcement patrol vehicles with public address systems announce evacuation order
 - House-to-house verification that threatened home site developments are completely evacuated
 - Law enforcement vehicles and ATVs drive back country roads and trails to assure evacuation
 - Use one color flagging to mark secondary roads/trails at their junction with the primary road (evacuation route) when notification is in progress then change to another color when verification is complete on that road/trail.
- 9) Drive evacuation routes installing free standing traffic control signs at key road intersections and opening locked gates or cutting fences to allow exit.
- 10) CSFS notify Federal Emergency Management Agency (FEMA)
- 11) Notify Colorado State Patrol Assign law enforcement to direct traffic at critical road junctions

The officer in charge of the evacuation will make the decision regarding which evacuation route to use at the time. Depending on the situation the decision may be to use any or all of the routes to evacuate the threatened area.

Emergency Evacuation Routes

Primary emergency evacuation routes are suggested but should be validated with landowners and land management agencies involved prior to the onset of an emergency need for evacuation. These primary evacuation routes should provide multiple opportunities for evacuating traffic to exit the area. Hazardous fuel concentrations should be treated along primary evacuation routes by creating shaded fuelbreaks to reduce canopy cover to 40 percent or less and treat slash and combustible debris within 200 to 300 feet of either side of the road. Tributary roads

should be identified in local developments and treated similarly to facilitate a safe and orderly evacuation.

WUI COMMUNITY	WAYS IN & OUT	ROAD IDENTIFIERS
Spirit Mountain Ranch	2	Eagle Court and Spirit Mountain Place to Spirit Mountain Drive then east to CR 43.6 (Gulnare Road) or south to CR 46.(Apishapa Road).

Estimated Time to Implement an Evacuation

The decision to evacuate a threatened area must be made well in advance of the time the fire is expected to threaten residents, visitors and facilities.

Fire Behavior and Evacuation Timing

Spread Component (SC) is the key fire danger component to monitor. The spread component is a numerical value derived from a mathematical model that integrates the effects of wind and slope with fuel bed and fuel particle properties to compute the forward rate of spread at the head of the fire. Output is in units of feet per minute. A spread Component of 31 indicates a worst-case, forward rate of spread of approximately 31 feet per minute.

The inputs required in to calculate the SC are wind, slope, fine fuel moisture (including the effects of green herbaceous plants), and the moisture content of the foliage and twigs of living, woody plants.

Since characteristics through which the fire is burning are so basic in determining the forward rate of spread of the fire front, a unique SC table is required for each fuel type.

When considering spotting, the rich diversity of fuel types scattered throughout the County, and the likelihood of wind, it may be prudent, when fire danger is Very High, to consider starting an evacuation process when fires are burning within 10 miles of down-wind subdivisions or home site development areas (urban interface area). Knowing the SC for the most prevalent fuel type between where the fire is and where the home site developments are can best refine this judgment call. With a SC of 44 a fire will cover 2 miles or more within 4 hours. If the SC is 22 the fire will cover at least one mile within 4 hours and 2 miles within 8 hours. If the SC is 11 the fire will cover two miles within 16 hours. If the SC is 5 the fire can cover two miles within 32 hours.

Remember the lessons of some Colorado fires:

- The Buffalo Creek Fire ran nearly eleven miles in 4.5 hours
- The Hayman Fire ran at least 16 miles in one afternoon

Timing

Evacuation planning needs to take into account how long it will take to notify residents that an evacuation is necessary, how long it will take for them to get ready and start driving out of the area and then how long it takes to actually drive to a safe

area. This determination should be made locally for each development area or subdivision and then validated before it is used during an emergency.

Every situation will be different but it is reasonable to estimate the minimum time required to be no less than 4 hours to complete the process. As much as three hours may be required to notify residents and visitors and get them started moving and another hour to get everyone out of the area. Residents and visitors closest to the advancing threat should be notified first. Once they are driving out of the area it will take them up to an hour in most cases to exit the area if traffic is flowing at a rate of 10 to 20 miles per hour.

Driving time should be measured on each of the potential evacuation routes by driving at a conservative speed depending on road conditions and how many people are expected to be evacuated to approximate how long it would take to drive the route during an evacuation providing traffic was moving at about that rate. The following table displays the type of information that needs to be incorporated in the Evacuation Plan.

Travel Time for Evacuation Routes

Beginning Point	Ending Point	Time Required	Miles Traveled	Average Speed

GPS Locations for Critical Features and Facilities – This table provides GPS coordinate locations for critical points referred to.

Feature	GPS Location

Recommendations

- Negotiate agreements with neighboring private land owners and land managing agencies to allow evacuation across their property on their roads and through their locked gates.
- Negotiate an agreement to thin fuels along the evacuation route between the subdivision or home development area and safe areas.
- Upgrade roads on evacuation routes by widening curves, providing water bars to prevent erosion and thinning fuels along these emergency exits.
- Construct and store freestanding “Fire Exit Directional Signs” or “Evacuation Route” for use in marking evacuation routes.
- Develop a specific evacuation procedure and assign responsibilities to County staff.

Is Your Home Protected



From Wildfire Disaster?



A Homeowner's Guide
to Wildfire Retrofit

acknowledgments

The staff of the Institute for Business & Home Safety (IBHS) wishes to acknowledge the valuable input of all those involved in the preparation of this booklet. In particular, we extend our thanks to:

The IBHS Wildfire Committee Members
National Fire Protection Association
State Farm Fire and Casualty Company
National Institute of Standards & Technology
US Geological Survey
Insurance Services Office, Inc.
The Hartford Financial Services Group
California FAIR Plan Association
Allstate Insurance Company

Architectural Illustrations:
W. Spaulding, AIA

Photography:
Cover: Incident scenes; post-burn/damages
Courtesy National Interagency Fire Center, Boise, Idaho
Cover and page 1: Bitterroot National Forest, Montana
Courtesy National Interagency Fire Center, Boise, Idaho
Cover and page 2: Pine Barrens
© J Smalley, NJ
Opposite Table of Contents: Florida Wildfire
© AP/Wide World Photos

Disclaimer

The purpose of this document is to provide homeowners with guidance on ways to retrofit and build homes to reduce losses from wildfire damage. It contains suggestions and recommendations based on professional judgment, experience and research and is intended to serve only as a guide. The authors, contributors and publisher disclaim all warranties and guarantees with respect to the information in the document and assume no liability or responsibility with respect to the information.

“Nature...she pardons no mistakes.”

Ralph Waldo Emerson



© AP/Wide World Photos

An April 2001 Florida wildfire caused Olga Gutierrez to desperately fight a fire behind her Port Charlotte, FL home with water from her pool.

In 1993, a wildfire in a dry canyon north of Laguna Beach, California, raced toward hundreds of nearby homes, giving residents little advance warning of its awesome destruction. More than 14,000 acres and 440 homes went up in flames.

In the nearby Mystic Hills neighborhood, 286 homes were totally destroyed. Yet, there was one white house left standing in the midst of hundreds of piles of smoking ash that remained of its neighboring homes. This sole surviving house was built with fire prevention in mind. It stood as an example of how homes can, with a little extra attention, better withstand nature's perils. The practical methods used in and around that house can help reduce the chances of future wildfires from reducing communities to ashes. This guide is designed to make that one rare exception of survival a more common occurrence in the future.

table of contents

Introduction	1
Wildfires and Your Home	2
The Wildland/Urban Interface Problem.....	2
You and Your Local Fire Department.....	2
Just the Right Conditions.....	3
How Your Home Catches Fire.....	4
Taking Inventory - Is your property at risk?	4
What's Your Risk Level?	5
What You Can Do to Reduce Your Risk.....	5
Your Home's Landscape	7
Creating a Survivable Space.....	7
The Importance of Maintenance.....	7
Your Home's Building Materials and Design	8
The Ideal Fire-Resistant Home	8
Taking Inventory	8
Taking Action.....	9
Helping Your Local Fire Department	12
Wildfire Safety Project List	13
Wildfire Protection Checklist	14
References	19
Additional Sources of Information	20

Large Fire Locations

January 1 to October 3, 2000



*Courtesy National Interagency Fire Center
Boise, Idaho*

introduction

Nearly every state has been devastated by wildfires in the last century. More than 140,000 wildfires occur on average each year. Since 1990, more than 900 homes have been destroyed each year by wildfires.

So, what can you do to protect yourself, your home and property from wildfires? This guide will help you understand

- why your home is at risk, and
- how you can reduce the risk to your home and property.



*Bitterroot National Forest, Montana
John McColgan
FairBanks, AK • August 6, 2000*

wildfires and your home

The Wildland/Urban Interface Problem

Wildfires occur regularly. Whether started by humans or by lightning, they are part of a natural cycle that helps to maintain the health of our forests. Today, more than ever, people are moving into remote areas, with the desire to "get back to nature," without addressing the dangers that exist around them.

A tremendous wildfire danger exists where homes blend together with the wildland, creating the wildland/urban interface. The addition of homes there interrupts the natural cycle of wildfires. Ultimately,

this contributes to a dangerous build-up of old vegetation, leading to an uncontrollable wildfire.

You and Your Local Fire Department

In a wildfire, your local fire department has two priorities – to remove you and your family from harm's way and to stop the progression of the wildfire. If your home happens to be in the wildfire's path, they may or may not be able to protect it – there are simply no guarantees.

Consequently, you must take action before a fire starts.



© J Smalley, NJ • Pine Barrens

Just the Right Conditions

Conditions must be just right for a wildfire to start and spread. Specifically, fuel, weather and topography work together to determine how quickly a wildfire travels and at what intensity.

Fuels: The two basic fuel types in the wildland/urban interface are vegetation and structures.

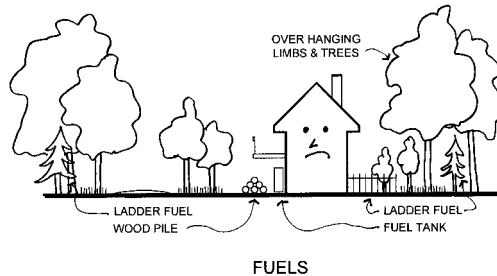

Vegetation: Fuel in its natural form consists of living and dead trees, bushes and grasses. Typically, grasses burn more quickly and with less intensity than trees. Any branches or shrubs between 18 inches and 6 feet are considered to be ladder fuels. Ladder fuels help convert a ground fire to a crown fire (tree tops) which moves much more quickly.

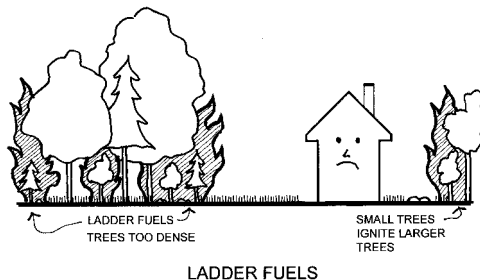

Structural Density: The closer the homes are together, the easier it is for the flames to spread from one structure to another.

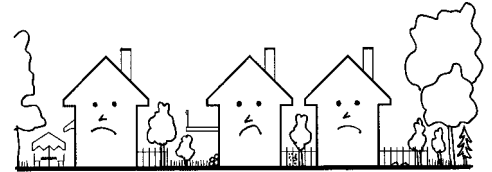

STRUCTURAL DENSITY

Weather: High temperatures, low humidity, and swift winds increase the probability of ignitions and difficulty of control. Short and long-term drought further exacerbates the problem.

Slope: Slope is the upward or downward incline or slant of terrain. For example, a completely flat plain represents a 0% slope and a hillside that rises 30 feet for every 100 feet horizontal distance represents a 30% slope.

Hot gases rise in front of the fire along the slope face, pre-heating the up-slope vegetation, moving a grass fire up to four times faster with flames twice as long as a fire on level ground.

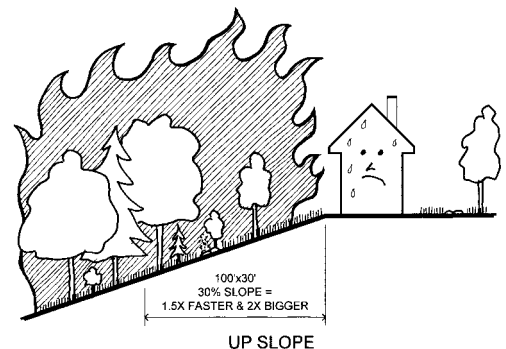

How Your Home Catches Fire

There are three ways that the wildfire can transfer itself from the natural vegetation or other burning homes to your home – through radiation, convection or firebrands.

Radiation: Wildfires can spread to your home by radiating heat in the same way a radiator heats your rooms in the wintertime. Radiated heat is capable of igniting combustible materials from distances of 100 feet or more.

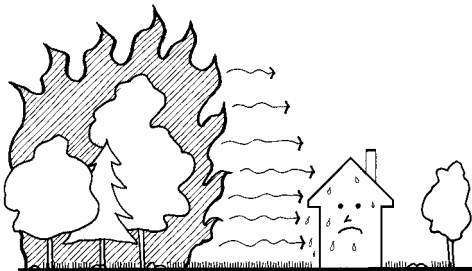

RADIATION

Convection: Contact with the convection column (flames) may also cause the wildfire to ignite your house. Typically, the convec-

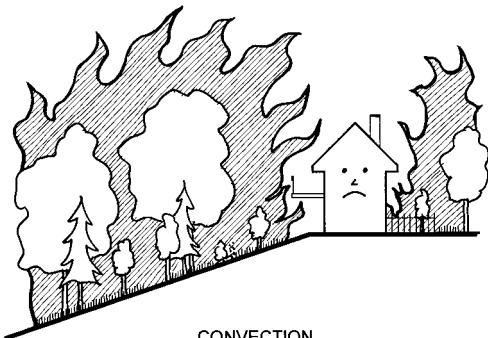

CONVECTION

tive heat column rises vertically, within the smoke plume.

Firebrands: Firebrands are burning materials that detach from a fire during strong convection drafts in the burning zone. Firebrands can be carried long distances – more than a mile – by the winds associated with the wildfire.



FIREBRANDS

In all cases, your home's building materials and design play a significant role in establishing the level of exposure that can be endured before ignition from radiation, convection, firebrands or any combination of these three.

Taking Inventory – Is Your Property at Risk?

The first step in establishing your risk is to assess your property. The table on page 5 lists numerous factors and issues that you should consider.

This assessment will give you a good sense of your property's wildfire risk.

Assessing Your Property

- | | |
|--|--|
| <input type="checkbox"/> Have wildfires occurred in your area? If so, under what conditions? | <input type="checkbox"/> Is there a substantial amount of tall vegetation crowded in around your home? |
| <input type="checkbox"/> Do you have seasons when wildfires are more likely to occur? | <input type="checkbox"/> Do tree limbs extend over your home? |
| <input type="checkbox"/> Do you live in hilly or flat country? | <input type="checkbox"/> Are the trees in good condition or are they dying? |
| <input type="checkbox"/> Are there areas around your home that are more susceptible to a wildfire? | <input type="checkbox"/> Do you have a woodpile in close proximity to your home? |
| <input type="checkbox"/> Do you border wildland? | <input type="checkbox"/> Do you have any fuel tanks nearby? |
| <input type="checkbox"/> Have you used native vegetation in your landscaping? | <input type="checkbox"/> Is a wood fence attached to your home? |

What's Your Risk Level?

The rough categories that follow on page 6 are not meant to give you an absolute score, but are to help guide you when deciding how to best protect your home.

What You Can Do To Reduce Your Risk

Homes in a wildland/urban interface area can be designed and maintained to increase the chances of surviving a wildfire without the intervention of the fire department.

This guide will help you protect your home on two different fronts:

- Your Home's Landscape
- Your Home's Building Materials and Design

Low Risk Areas:

- Little or no history of nearby wildfires
- Humid climate, short dry season
- Flat terrain (no grades greater than 9%)
- Limited wildland
- Home not crowded by trees
- Landscape includes native vegetation
- Manmade fuels at least 50 feet from your home.
- Fire hydrant within 300 feet
- Easy access for fire trucks

Moderate Risk Areas:

- History of wildfires
- Climate includes a dry season less than 3 months
- Hilly terrain (grades average between 10% and 20%)
- Bordering a wildland with light brush, small trees or grass
- Trees are located in close proximity to your home
- Native vegetation has or has not been incorporated into your landscape
- Manmade fuels are within 50 feet of your home
- Fire hydrant within 500 feet
- Access for fire trucks

High Risk Areas:

- History of nearby wildfires
- Dry climate with a dry season more than 3 months
- Steep terrain (grades average over 20%)
- Forested wildland within 100 feet of your home
- Native vegetation has not been incorporated into your landscape
- Trees are crowded within 30 feet of your home
- Manmade fuels within 30 feet of your home
- No fire hydrants
- Limited access for fire trucks

your home's landscape

Creating a Survivable Space For Your Home

A survivable space is an area of reduced fuels between your home and the untouched wildland. This provides enough distance between the home and a wildfire to ensure that the home can survive without extensive effort from either you or the fire department.

One of the easiest ways to establish a survivable space is to use the zone concept. Zone 1 is the closest to your home and Zones 2 and 3 move progressively further away.

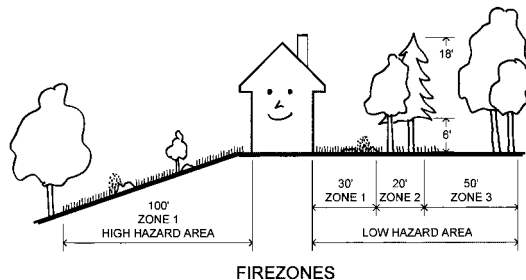

Zone 1: Establish a well-irrigated area around your home. In a low hazard area, it should extend a minimum of 30 feet from your home on all sides. As your hazard risk increases, a clearance of between 50 and 100 feet or more may be necessary, especially on any downhill sides of the lot. Plantings should be limited to carefully spaced indigenous species.

Zone 2 Place low-growing plants, shrubs and carefully spaced trees in this area. Maintain a reduced amount of vegetation. Your irrigation system

should also extend into this area.

Trees should be at least 10 feet apart, and all dead or dying limbs should be trimmed. For trees taller than 18 feet, prune lower branches within six feet of the ground. No tree limbs should come within 10 feet of your home.

Zone 3: This furthest zone from your home is a slightly modified natural area. Thin selected trees and remove highly flammable vegetation such as dead or dying trees and shrubs.

So how far should Zones 2 and 3 extend? Well, that depends upon your risk and your property's boundaries.

In a low hazard area, these two zones should extend another 20 feet or so beyond the 30 feet in Zone 1. This creates a modified landscape of over 50 feet total.

In a moderate hazard area, these two zones should extend at least another 50 feet beyond the 50 feet in Zone 1. This would create a modified landscape of over 100 feet total.

In a high hazard area, these two zones should extend at least another 100 feet beyond the 100 feet in Zone 1. This would create a modified landscape of over 200 feet total.

The Importance of Maintenance

Once you have created your home's survivable space, you must maintain it or risk losing the benefit of its protection.

your home's building materials and design

Creating and maintaining a survivable space is a necessary first step. The next step is to use fire resistant building materials and construction techniques in retrofitting your home.

The Ideal Fire-Resistant Home

Keep in mind that a wildfire sees your home as just another fuel

source. The survivable space you construct around your home will keep all but the most ferocious wildfires at bay. However, if the wildfire does break through your first line of defense, an ignition might occur on your home's exterior. The ideal situation is for your home's exterior materials to prevent or retard the flames from burning into your interior walls, soffits, attic area, and rooms.

Taking Inventory

Examine your home's construction and materials. Use the following as a checklist.

- What type of roof covering do you have? Asphalt, wood, concrete, tile or metal?
- How are your eaves, fascias and soffits constructed? Are they made from vinyl, wood or metal?
- What are your home's exterior walls covered with? Are they wood, aluminum or vinyl siding, stucco, brick or concrete masonry?
- Do you have large windows or sliding glass doors that border or face the wildland? Are they single pane, double pane or tempered glass?
- How are your home's attic and sub-floor vents protected? Are their covers metal or vinyl?
- Are spark arresters installed on all your home's chimneys?
- Does your home have a deck or balcony that overhangs a slope?
- Is there a porch, garage or wood fence that attaches directly to your home?

Taking Action

Now you will need to decide on the best modifications for your home, given your risk.

Roof: The roof is the most vulnerable part of your home to wildfires. During a wildfire, firebrands can fall on your roof, landing in your roof's nooks and crannies where a fire can easily start. Once your roof covering does ignite, chances are very good that the rest of your home will follow.

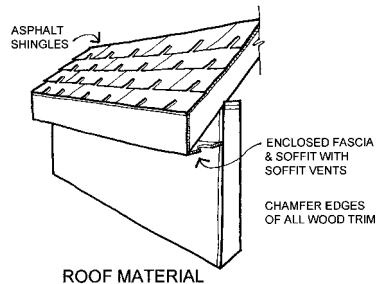
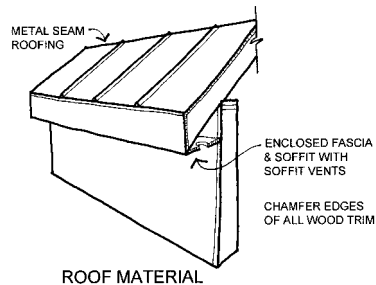

The best way to avoid this situation is to make sure your roof is fire-resistant. The two main fire resistance tests used today include: ASTM E108 and UL 790. There are three levels of classification awarded under the test protocol, A, B, and C, with A being the most

fire resistant. Some treated wood shake shingle products have ratings of Class C or better. Over time, the effectiveness of this chemical is reduced by weathering before the end of the product's useful life and may leave your roof unprotected.

If your roof needs to be re-covered, consider installing a Class A roof covering.

Exterior Walls: Exterior walls are susceptible to a wildfire's radiant and convective heat. Although a fire on an exterior wall may not penetrate inside your home, the fire can 'bridge' to more vulnerable areas such as eaves, soffits, vents and windows.

Wall materials that resist heat and flames include cement, plaster, stucco and concrete masonry such as stone, brick or block. Though some materials will not burn, such as vinyl, they may lose their integrity when exposed to high temperature and fall away or melt, providing the fire with a direct path inside the home.

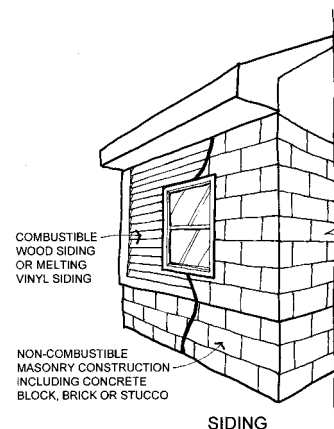

Exterior Windows, Glass Doors and Skylights: Exposure to the heat of the wildfire can cause glass to fracture and collapse, leaving an opening for flames and firebrands to enter your home. This applies to both double pane and single pane glass, since double pane glass is only slightly more resistant to heat than single pane glass.

On the other hand, single or double pane tempered glass windows, doors and skylights typically fracture at higher exposures, well above the radiant heat exposures capable of igniting the surrounding wood.

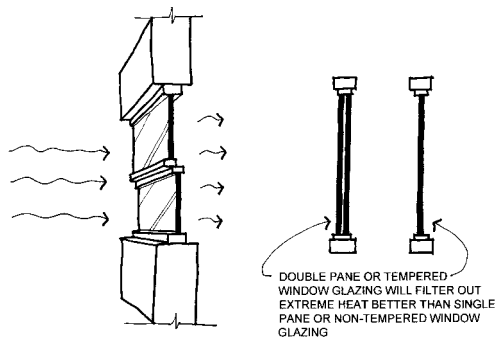

WINDOW GLAZING

Eaves, Fascias, Soffits: Eaves, fascias and soffits are vulnerable to both firebrands and convective exposures.

Eaves, fascias and soffits should be ‘boxed’ or enclosed with noncombustible materials to reduce the size of the vents. Materials that melt or

burn in relatively low temperatures, such as PVC and vinyl siding, should not be used, since they do not provide adequate protection and can melt in the heat of the wildfire. Non-combustible screening should be used in the vents.

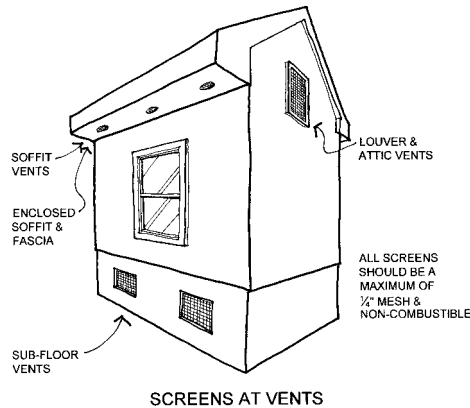

Attic, Subfloor or Foundation Vents: Wind and/or direct contact with a fire’s convective heat can push firebrands through the vents into your home’s basement or crawl space.

Your vent openings should be screened to prevent firebrands or other objects larger than 1/4 inch from entering your home. Both your vents and screens should be constructed of materials that will not burn or melt when exposed to radiate or convective heat or firebrands. Also, these vents should be corrosion-resistant to help minimize required maintenance.

Fireplace Chimneys: Windblown embers can access your home through your fireplace's chimney flue. Once inside, these firebrands then collect on flammable objects, greatly increasing the chance of combustion. The situation can also be reversed: embers from your own fire can fly out the chimney and start a wildfire, right in your own neighborhood.

The best way to avoid this situation is to install a spark arrestor made from welded wire or woven wire mesh with openings less than 1/4" wide.

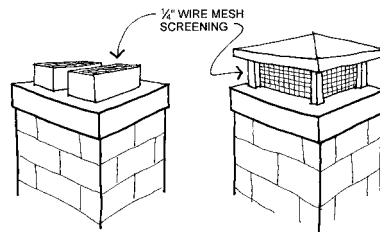

CHIMNEY SCREENS

Overhangs and Other Attachments: Overhangs and other attachments include any additional structures attached to a residence such as room pushouts, bay windows, decks, porches, carports and fences. These features are often very vulnerable to convective exposures.

When assessing your home and property, if the feature in question is attached to your home, it should be considered part of your home.

There are a number of ways you can reduce the vulnerability of your home's overhangs and attachments. First and foremost, remove all fuels around these areas. Next, box in the undersides of the overhangs, decks and balconies with noncombustible or fire-resistant materials to reduce the possibility of ignition. For fences, make sure that they don't attach directly to your home.

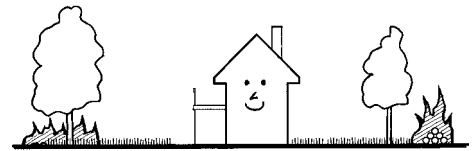

WOOD PILES, DECKS, FENCES, ETC.

helping your local fire department

Even if you modify your home's landscape to incorporate the most fire-resistant materials and design into your home's construction, there is no guarantee that a wildfire will not threaten your home. It is important that your local fire department be able to find and defend your home.

Here are some suggestions on how to modify your property to accommodate your local fire department.

Street Signs and Numbers: If made from combustible materials, your street signs and numbers can ignite or melt, leaving the fire department with no ability to locate your home. It is critical that signs and numbers be noncombustible and visible from the road.

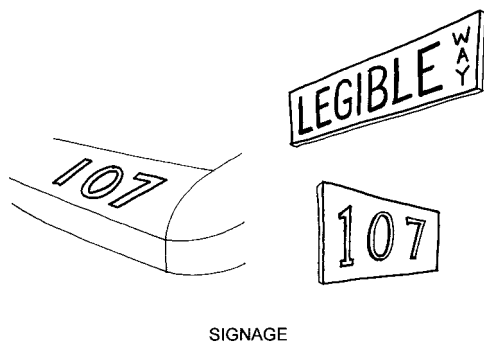

Driveways: Fire trucks and equipment are quite large and often have difficulty in tight spots. Consequently, your home's driveway must be large enough to accommodate the typical sized trucks. Fire experts recommend a driveway at least 12 feet wide and 13 feet of vertical clearance.

Gates: If your home is gated, it is very important that the gate opens inward and be wide enough to accommodate the fire fighting equipment. Experts also recommend that the gate be at least 30 feet off of the main road, so that the equipment can pull off the road to open the gate. If the gate is locked, the lock should not be so strong that firefighters cannot break it in an emergency.

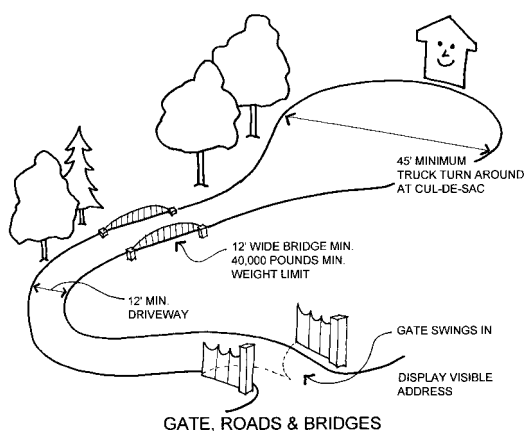

wildfire safety project list

This list of home improvements is divided into cost categories. You can tackle these projects one at a time, but remember, the more you do, the better protected your home will be against wildfires.

Category \$ (<\$300)

- Creating a survivable space;
- Maintaining your survivable space;
- Installing fire-resistant signs and address numbers;
- Modifying your attic, sub-floor, and basement vents;
- Installing a spark arrestor on your chimney.

Category \$\$ (\$300 – \$1000)

- Boxing in overhangs and modifying other attachments;
- Boxing in your eaves, facias, and soffits.

Category \$\$\$ (>\$1000)







- Re-covering your exterior walls with a more fire-resistant material;
- Replacing single-pane glass windows, doors, or skylights with tempered glass;
- Modifying your driveway, bridges, and gates to accommodate fire trucks.
- Re-roofing your home with a Class A roof covering.

WILDFIRE PROTECTION CHECKLIST







Before, During and After: Be Completely Prepared

You will give yourself and your family a better chance of escaping harm during a wildfire by taking as many of the precautions outlined in this brochure as possible. But, these steps are only the beginning. To protect yourself as completely as possible, here are some added suggestions:











before a wildfire strikes:

	Know where your gas, electric and water main shut-off controls are and how to turn them off if there is a leak or electrical short. Also, know how to use a fire extinguisher. Make sure all adult and teenage members of your family know how to shut off each utility and to use the extinguisher.
	Become familiar with your community's disaster-preparedness plans and create a family plan. Know where the closest police, fire and emergency medical facilities are located.
	Plan several different escape routes from your home and neighborhood and designate an emergency meeting place for the family to reunite. Establish a contact point to communicate with concerned relatives.
	Put together an emergency kit that includes at least a three-day supply of drinking water and food that needs no refrigeration and, generally, no cooking; emergency cooking equipment, if required; a portable NOAA weather radio; first aid supplies and medications; basic tools, such as a wrench, a flashlight and gloves; portable lanterns and batteries; credit cards and cash; and important documents, including insurance policies.
	Talk to your neighbors about wildfire safety. Plan how the neighborhood could work together before, during and after a wildfire. Make a list of your neighbors' skills such as medical or technical. Consider how you would help neighbors who have special needs such as elderly or disabled persons. Make plans to take care of children who may be on their own if parents can't get home.
	Periodically review your homeowner's insurance policy with your insurance agent or company to make sure that, if you are the victim of a disaster, you have enough coverage to rebuild your home and life.





during a wildfire:

	If you are warned that a wildfire is threatening your area, listen to your portable radio for reports and evacuation information. Follow the instructions of local officials.
	Back your car into the garage or park it in an open space facing the direction of escape. Shut car doors and roll up windows. Leave the key in the ignition or in another easily accessible location.
	Close garage windows and doors, but leave them unlocked. Disconnect automatic garage door openers.
	Confine pets to one room. Make plans to care for your pets in case you must evacuate.
	Arrange temporary housing outside the threatened area.
	When advised to evacuate, do so immediately.
	Wear protective clothing – sturdy shoes, cotton or woolen clothing, long pants, a long-sleeved shirt, gloves and a handkerchief to protect your face.
	Take your emergency kit.
	Lock your home.
	Notify your relatives and the local officials that you have left and where you can be reached.
	Follow the evacuation route that your local officials have identified. If no official route exists, choose a route away from fire hazards. Watch for changes in the speed and direction of the fire and smoke.

If you are SURE you have the time, take additional steps to protect your home:

	Close windows, vents, doors, venetian blinds and heavy drapes. Remove lightweight curtains.
	Shut off gas at the meter. Turn off pilot lights.
	Move flammable furniture into the center of the home away from windows and sliding-glass doors.
	Turn on a light in each room to increase the visibility of your home in heavy smoke.
	Seal attic and ground vents.
	Turn off propane tanks.
	Place combustible patio furniture inside.
	Connect the garden hose to outside taps.
	Place lawn sprinklers on the roof and near aboveground fuel tanks. Wet the roof.
	Wet or remove shrubs within 15 feet of the home.
	Gather fire tools, including a rake, axe, hand/chainsaw, bucket and shovel.

after a wildfire strikes:

	Listen to and follow the advice and recommendations of the local aid organizations, including the emergency management office, the fire department and the utility companies.
	Check for hazards, such as gas or water leaks and electrical shorts. Turn off damaged utilities. Have the fire department or gas and electric companies turn the utilities back on when the area is secured.
	Check for injuries and administer first aid as needed.
	Check your food and water supplies. Do not eat anything from open containers near shattered glass.

references

American Society for Testing and Materials. Standard Test Methods for Fire Testing of Roof Coverings ASTM E108. West Conshohocken, PA: ASTM, 2000.

Insurance Services Office, Inc. The Wildland/Urban Fire Hazard. New York, NY: ISO, 1997

International Fire Code Institute Urban-Wildland Interface Code. Whittier, CA: IFCI, 2000

National Fire Protection Association
Firewise Landscaping Videotapes (3) and Checklist. Firewise Construction Videotapes and Checklist. Quincy, MA: NFPA, 1994

- Protecting Your Home from Wildfire. Quincy, MA: NFPA, 1987

- Standard for Protection of Life and Property from Wildfire NFPA 299. 1997 Edition. Quincy, MA: NFPA, 1997.

NFPA Journal
Wildland/Urban Interface Fires. Quincy, MA: NFPA, March/April.

National Wildland/Urban Interface Fire Protection Program. Wildland/Urban Interface Fire Hazard Assessment Methodology. Washington, DC: 1997

Underwriters Laboratories
Tests for Fire Resistance of Roof Covering Materials. UL 790. Northbrook, IL: 1997

Alberta Environment Land and Forest Service
FireSmart: Protecting Your Community from Wildfire. Partners in Protection. Edmonton, Alberta: May 1999.

appendix I: additional sources of information

California Department of Forestry and Fire Protection (CDF)

<http://www.fire.ca.gov/>

Colorado State University/Colorado Forestry Service

<http://lamar.colostate.edu/~firewise/>

Firewise

<http://www.firewise.org/>

National Interagency Fire Center (NIFC)

<http://www.nifc.gov/>

U.S. Forest Service

<http://www.fs.fed.us/fire/>

Wildfire News

<http://www.wildfirenews.com/>



1408 North Westshore Blvd., Suite 208, Tampa, FL 33607
1 (866) 657-IBHS(4247) • Fax (813) 286-9960 • <http://www.ibhs.org/>

APPENDIX E–FireWise “The Homeowner’s Guide to Wildfire Retrofit”



Fuelbreak Guidelines for Forested Subdivisions & Communities

By

Frank C. Dennis



Knowledge to Go Places

This publication was developed for use by foresters, planners, developers, homeowners' associations and others. Implementation of these measures cannot *guarantee* safety from all wildfires, but will greatly increase the probability of containing them at more manageable levels.



Inadequate fire planning can result in loss of life or property and costly suppression activities.



Colorado's forested lands are experiencing severe impacts from continuing population increases and peoples' desire to escape urban pressures. Subdivisions and developments are opening new areas for homesite construction at an alarming rate, especially along the Front Range and around recreational areas such as Dillon, Vail, and Steamboat Springs.

But with development inevitably comes a higher risk of wildfire as well as an ever-increasing potential for loss of life and property. Methods of fire suppression, pre-suppression needs, and homeowner and fire crew safety must all be considered in the planning and review of new developments as well as for the "retrofitting" of existing, older subdivisions.

Fuelbreaks should be considered in fire management planning for subdivisions and developments; however, the following are guidelines **only**. They should be customized to local areas by professional foresters experienced in Rocky Mountain wildfire behavior and suppression tactics.

Fuelbreak vs Firebreak

Although the term fuelbreak is widely used in Colorado, it is often confused with firebreak. The two are entirely separate, and aesthetically different, forms of forest fuel modification and treatment.

- A firebreak is strip of land, 20 to 30 feet wide (or more), in which all vegetation is removed down to bare, mineral soil each year prior to fire season.

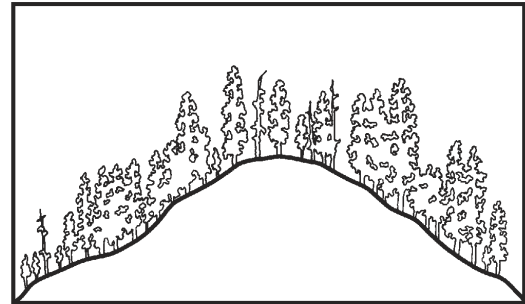

Above, cross section of mixed conifer stand before fuelbreak modification. Below, after modification.

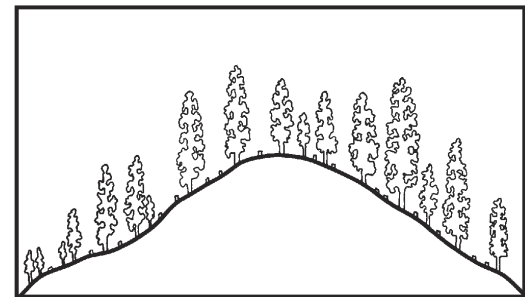

- A fuelbreak (or shaded fuelbreak) is an easily accessible strip of land of varying width (depending on fuel and terrain), in which fuel density is reduced, thus improving fire control opportunities. The stand is thinned, and remaining trees are pruned to remove ladder fuels. Brush, heavy ground fuels, snags, and dead trees are disposed of and an open, park-like appearance is established.

The following is a discussion of the uses, limitations, and specifications of fuelbreaks in wildfire control and fuels management.

Fuelbreak Limitations

Fuelbreaks provide quick access for wildfire suppression. Control activities can be conducted more safely due to low fuel volumes. Strategically located, they break up large, continuous tracts of dense timber, thus limiting uncontrolled spread of wildfire.

Fuelbreaks can aid firefighters greatly by slowing fire spread under normal burning conditions. However, under extreme conditions, even the best fuelbreaks stand little chance of arresting a large



Before and after photos of a forest stand thinned to reduce fuel loads.

fire, regardless of firefighting efforts. Such fires, in a phenomenon called “spotting,” can drop firebrands 1/8-mile or more ahead of the main fire, causing very rapid fire spread. These types of large fires may continue until there is a major change in weather conditions, topography, or fuel type.

It is critical to understand: A fuelbreak is the line of defense. The area (including any homes and developments) between it and the fire may remain vulnerable.

In spite of these somewhat gloomy limitations, fuelbreaks have proven themselves effective in Colorado. During the 1980 Crystal Lakes Subdivision Fire near Fort Collins, crown fires were stopped in areas with fuelbreak thinnings, while other areas of dense lodgepole pine burned completely. A fire at O’Fallon Park in Jefferson County was successfully stopped and controlled at a fuelbreak. The Buffalo Creek Fire in Jefferson County (1996) and the High Meadow Fire in Park and Jefferson Counties (2000) slowed dramatically wherever intense forest thinnings had been completed. During the 2002 Hayman Fire, Denver Water’s entire complex of offices, shops and caretakers’ homes at Cheesman Reservoir were saved by a fuelbreak with no firefighting intervention by a fuelbreak.



Burned area near Cheesman Reservoir as a result of the Hayman Fire. Note the unburned green trees in the middle right of the photo, a treated fuelbreak.

The Need For A Fuelbreak

Several factors determine the need for fuelbreaks in forested subdivisions, including: (1) potential problem indicators; (2) wildfire hazard areas; (3) slope; (4) topography; (5) crowning potential; and (6) ignition sources.

Potential Problem Indicator

The table below explains potential problem indicators for various hazards and characteristics common to Colorado’s forest types. All major forest types, except aspen, indicate a high potential for wildfire hazard.

Fuel Type	Characteristics			Hazards			
	Aesthetics	Wildlife	Soil	Wildfire	Avalanche	Flood	Climate
Aspen	2	3	3	2	4	3	2
Douglas-fir	2	2	3	5	2	2	3
Greasewood-Saltbrush	4	2	2	2	1	3	3
Limber-Bristlecone Pine	3	2	4	3	4	2	5
Lodgepole Pine	2	2	3	5	4	2	4
Meadow	5	4	4	2	3	4	3
Mixed Conifer	2	1	1	5	3	1	3
Mountain Grassland	5	3	4	3	3	2	4
Mountain Shrub	3	5	4	4	2	2	3
Piñon-Juniper	2	3	4	4	2	3	2
Ponderosa Pine	2	3	1	5	2	2	3
Sagebrush	4	4	3	3	3	2	3
Spruce-Fir	2	3	3	4	5	3	4

Legend: 5 – Problem may be crucial; 4 – Problem very likely; 3 – Exercise caution; 2 – Problem usually limited; 1 – No rating possible

Wildfire Hazard Maps

The Colorado State Forest Service (CSFS), numerous counties and some National Forests have completed wildfire hazard mapping for many areas within Colorado, particularly along the Front Range. These maps typically consider areas with 30 percent or greater slope; hazardous fuel types; and hazardous topographic features such as fire chimneys. Wildfire Hazard Ratings may be depicted in several ways. Whatever system is used, areas rated moderate or higher should be considered for fuel modification work.

Slope

Rate of fire spread increases as the slope of the land increases. Fuels are preheated by the rising smoke column or they may even come into contact with the flames themselves.

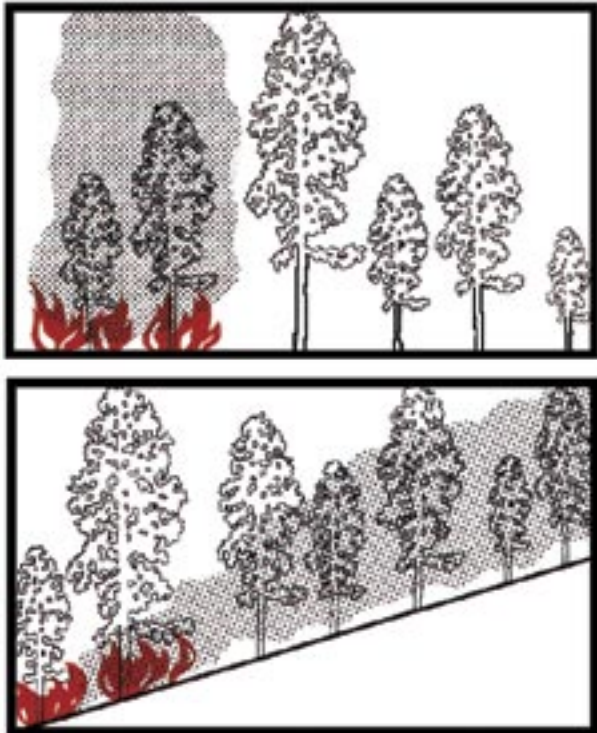

Fire effects, flat vs steep terrain. Note preheating of fuels on steep ground from passage of smoke column.

At 30 percent slope, rate of fire spread doubles compared to rates at level ground, drastically reducing firefighting effectiveness. **Areas near 30 percent or greater slopes are critical and must be reviewed carefully.**

Topography

Certain topographic features influence fire spread and should be evaluated. Included are fire chimneys, saddles, and V-shaped canyons. They are usually recognized by reviewing standard U.S.G.S. quad maps.

- Chimneys are densely vegetated drainages on slopes greater than 30 percent. Wind, as well as air pre-heated by a fire, tends to funnel up these drainages, rapidly spreading fire upslope.

- Saddles are low points along a main ridge or between two high points. Like chimneys, they also funnel winds to create a natural fire path during a fire's uphill run. Saddles act as corridors to spread fire into adjacent valleys or drainages.

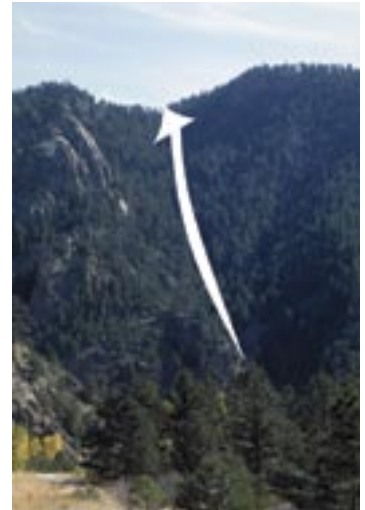

Chimney.



Saddle.

- Narrow, V-shaped valleys or canyons can ignite easily due to heat radiating from one side to the other. For example, a fire burning on one side of a narrow valley dries and preheats fuels on the opposite side until the fire "flashes over." The natural effect of slope on fire then takes over and fire spreads rapidly up drainage and uphill along both sides of the valley.



Flashover in V-shaped valley.

Crowning Potential

An on-site visit is required to accurately assess crowning potential. A key, below, helps determine this rating. Fuel modification is usually unnecessary if an area has a rating of 3 or less.

Crowning Potential Key

	Rating
A. Foliage present, trees living or dead — B	
B. Foliage living — C	
C. Leaves deciduous or, if evergreen, usually soft, pliant, and moist; never oily, waxy, or resinous.	0
CC. Leaves evergreen, not as above — D	
D. Foliage resinous, waxy, or oily — E	
E. Foliage dense — F	
F. Ladder fuels plentiful — G	
G. Crown closure > 75 percent	9
GG. Crown closure < 75 percent	7
FF. Ladder fuels sparse or absent — H	
H. Crown closure > 75 percent	7
HH. Crown closure < 75 percent	5
EE. Foliage open — I	
I. Ladder fuel plentiful	4
II. Ladder fuel sparse or absent	2
DD. Foliage not resinous, waxy, or oily — J	
J. Foliage dense — K	
K. Ladder fuels plentiful — L	
L. Crown closure > 75 percent	7
LL. Crown closure < 75 percent	4
KK. Ladder fuels sparse or absent — M	
M. Crown closure > 75 percent	5
MM. Crown closure < 75 percent	3
JJ. Foliage open — N	
N. Ladder fuels plentiful	3
NN. Ladder fuels sparse or absent	1
BB. Foliage dead	0

The majority of dead trees within the fuelbreak should be removed. Occasionally, large, dead trees (14 inches or larger in diameter at 4 1/2 feet above ground level) may be retained as wildlife trees. If retained, all ladder fuels must be cleared from around the tree's trunk.

Ignition Sources

Possible ignition sources, which may threaten planned or existing developments, must be investigated thoroughly. Included are other developments and homes, major roads, recreation sites, railroads, and other possible sources. These might be distant from the proposed development,

yet still able to channel fire into the area due to slope, continuous fuels, or other topographic features.

Fuelbreak Locations

In fire suppression, an effective fire line is connected, or "anchored," to natural or artificial fire barriers. Such anchor points might be rivers, creeks, large rock outcrops, wet meadows, or a less flammable timber type such as aspen. Similarly, properly designed and constructed fuelbreaks take advantage of these same barriers to eliminate "fuel bridges." (Fire often escapes control because of fuel bridges that carry the fire across control lines.)

Since fuelbreaks should normally provide quick, safer access to defensive positions, they are necessarily linked with road systems. Connected with county-specified roads within subdivisions, they provide good access and defensive positions for firefighting equipment and support vehicles. Cut-and fill slopes of roads are an integral part of a fuelbreak as they add to the effective width of modified fuels.

Fuelbreaks without an associated road system, such as those located along strategic ridge lines, are still useful in fire suppression. Here, they are often strengthened and held using aerial retardant drops until fire crews can walk in or be ferried in by helicopter.

Preferably, fuelbreaks are located along ridge tops to help arrest fires at the end of their runs. However, due to homesite locations and resource values, they can also be effective when established at the base of slopes. Mid-slope fuelbreaks are least desirable, but under certain circumstances and with modifications, these too, may be valuable.

Fuelbreaks are located so that the area under management is broken into small, manageable units. Thus, when a wildfire reaches modified fuels, defensive action is more easily taken, helping to keep the fire small. For example, a plan for a subdivision might recommend that fuelbreaks break up continuous forest fuels into units of 10 acres or less. This is an excellent plan, especially if defensible space thinning is completed around homes and structures, and thinning for forest management and forest health are combined with the fuelbreak.

When located along ridge tops, continuous length as well as width are critical elements. Extensive long-range planning is essential in positioning these types of fuelbreaks.

Aesthetics

Improperly planned fuelbreaks can adversely impact an area's aesthetic qualities. Careful construction is necessary when combining mid-slope fuelbreaks with roads involving excessive cut-and-fill.



These photos, far- and near- views of the same site, illustrate that forest can be thinned without impacting aesthetics.

Care must also be taken in areas that are not thinned throughout for fuel hazard reduction. In such cases the fuelbreak visually sticks out like a "sore thumb" due to contrasting thinned and unthinned portions of the forest. (Especially noticeable are those portions of the fuelbreak above road cuts).

These guidelines are designed to minimize aesthetic impacts. However, some situations may require extensive thinning and, thus, result in a major visual change to an area. Additional thinning beyond the fuelbreak may be necessary to create an irregular edge and to "feather," or blend, the fuelbreak thinning into the unthinned portions of the forest. Any thinning beyond the fuelbreak improves its effectiveness and is highly recommended.

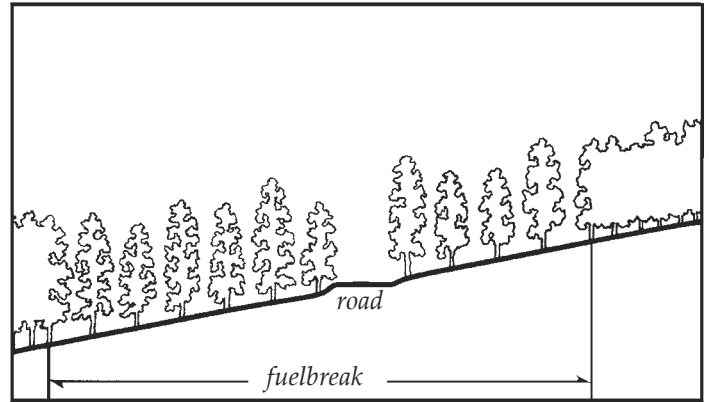

Cross-section of a typical fuelbreak built in conjunction with a road.

Constructing the Fuelbreak

Fuelbreak Width and Slope Adjustments

Note: Since road systems are so important to fuelbreak construction, the following measurements are from the toe of the fill for downslope distances, and above the edge of the cut for uphill distances.

The minimum recommended fuelbreak width is approximately 300 feet for level ground. Since fire activity intensifies as slope increases, the overall fuelbreak width must also increase. However, to minimize aesthetic impacts and to maximize fire crew safety, the majority of the increases should be made at the bottom of the fuelbreak, below the road cut.

Widths are also increased when severe topographic conditions are encountered. Guidelines for fuelbreak widths on slopes are given below:

Fuelbreak Width/Slope			
Percent Slope (%)	Minimum Uphill Distance (ft)	Minimum Downhill Distance (ft)	Total Width of Modified fuels (ft)*
0	150	150	300
10	140	165	303
20	130	180	310
30	120	195	315
40	110	210	320
50	100	225	325
60	100	240	340

*As slope increases, total distance for cut-and-fill for road construction rapidly increases, improving fuelbreak effective width.

Stand Densities

Crown separation is a more critical factor for fuelbreaks than a fixed tree density level. A *minimum* 10-foot spacing between the edges of tree crowns is recommended on level ground. As slope increases, crown spacing should also increase. However, small, isolated groups of trees may be retained for visual diversity. Increase crown spacing around any groups of trees left for aesthetic reasons and to reduce fire intensities and torching potential.

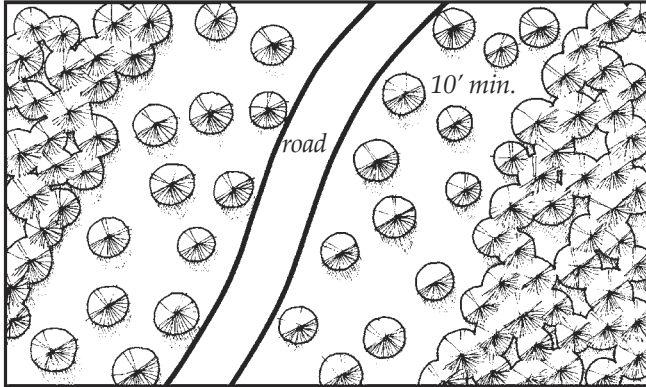

Plan view of fuelbreak showing minimum distance between tree crowns.

In technical terms, a fuelbreak thinning is classified as a heavy "sanitation and improvement cut, from below." Within fuelbreaks, trees that are suppressed, diseased, deformed, damaged, or of low vigor are removed along with all ladder fuels. Remaining trees are the largest, healthiest, most wind-firm trees from the dominant and co-dominant species of the stand.

Because such a thinning is quite heavy for an initial entry into a stand, prevailing winds, eddy effects, and wind funneling must be carefully evaluated to minimize the possibility of windthrow. It may be necessary to develop the fuelbreak over several years to allow the timber stand to "firm-up" — this especially applies to lodgepole pine and Engelmann spruce stands.

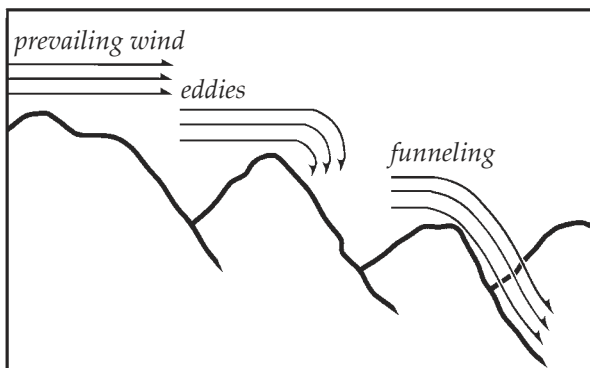

Topography affects wind behavior — an important consideration during fuelbreak construction.

Area-wide forest thinnings are recommended for any subdivisions. Such thinning is not as severe as a fuelbreak thinning, but generally should be completed to fuelbreak specifications along the roads (as outlined on page 6.) In addition, "defensible space thinnings" are highly recommended around all structures (see CSU Coop. Extension Fact sheet 6.302, *Creating Wildfire-Defensible Zones*).

Debris Removal

Limbs and branches left from thinning (slash) can add significant volumes of fuel to the forest floor, especially in lodgepole pine, mixed-conifer, or spruce/fir timber types. These materials can accumulate and serve as ladder fuels, or can become "jackpots," increasing the difficulty of defending the fuelbreak during a wildfire. **Slash decomposes very slowly in Colorado and proper disposal is essential.** Proper treatment reduces fire hazard, improves access for humans and livestock, encourages establishment of grasses and other vegetation, and improves aesthetics.

Three treatment methods are commonly used. These are lopping-and-scattering, piling and burning, and chipping. Mulching of small trees and slash using equipment similar to Hydro-axes or Timbcos equipped with mulching heads are becoming a popular method of treatment. Size, amount, and location of slash dictates the method used, in addition to cost and the final desired appearance. The method chosen will also depend on how soon an effective fuelbreak is needed prior to construction in new developments.



Lop and scatter: slash should be no deeper than 12" above ground surface.



Chipping is the most desirable, but also the most expensive method of slash disposal.



Piled slash can be burned but only during certain conditions, such as after a snowfall.

Fuelbreak Maintenance

Following initial thinning, trees continue to grow (usually at a faster rate). The increased light on the forest floor encourages heavy grass and brush growth where, in many cases, where little grew before. The site disturbance and exposed mineral soil created during fuelbreak development is a perfect seed bed for new trees that, in turn, create new ladder fuels. Thus, in the absence of maintenance, fuelbreak effectiveness will decrease over time.



Fuelbreak maintenance is essential. Ingrowth, shown above, will minimize the effectiveness of this fuelbreak within a few years.

Fuelbreak maintenance problems are most often the result of time and neglect. Misplaced records, lack of follow-up and funding, and apathy caused by a lack of fire events are some of the major obstacles. In addition, the responsibility for fuelbreak maintenance projects is often unclear. For example, control of a fuelbreak completed by a developer passes to a homeowner's association, usually with limited funds and authority to maintain fuelbreaks.

If fuelbreak maintenance is not planned and completed as scheduled, consider carefully whether the fuelbreak should be constructed. An un-maintained fuelbreak may lead to a false sense of security among residents and fire suppression personnel.

Conclusion

An image of well-designed communities for Colorado includes:

- Forested subdivisions where the total forest cover is well-managed through carefully planned, designed, and maintained thinnings. This contributes to reduced wildfire hazards and a much healthier forest — one that is more resistant to insects and disease.
- A system of roads and driveways with their associated fuelbreaks that break up the continuity of the forest cover and fuels. These help keep fires small, while also providing safer locations from which to mount fire suppression activities. In addition to allowing fire personnel in, they will allow residents to evacuate if necessary.
- Individual homes that all have defensible space around them, making them much easier to defend and protect from wildfire, while also protecting the surrounding forest from structure fires.

Creation of such communities is entirely feasible if recognition of the fire risks, a spirit of cooperation, an attitude of shared responsibility, and the political will exists.

*Colorado's mountains comprise diverse slopes, fuel types, aspects, and topographic features. This variety makes it impossible to develop general fuelbreak prescriptions for all locations. **The previous recommendations are guidelines only.** A professional forester with fire suppression expertise should be consulted to "customize" fuelbreaks for particular areas.*

APPENDIX F–Fuelbreak Guidelines for Forested Subdivisions & Communities

APPENDIX G – Road and Driveway Specifications for Emergency Access

Roads serving one dwelling unit shall meet the following:

- A. Roadway shall be a total of 14' in width, including a 10' all-weather travel surface and 2' shoulders (each side). Curves and turn a rounds should have a minimum of a 30' radius at centerline.
- B. Road grade should generally not be over 7 percent. A maximum grade 10 percent to 12 percent grade would be acceptable for short distances not over 150 feet.
- C. If the driveway is less than 50' the above (A and B) do not apply.
- D. If the length of the road exceeds 150', a turnaround shall meet (template 1 or 2) standards.

Roads serving more than one dwelling shall meet the following:

- A. Roadway shall be a total of 20' in width, including a 16' all weather travel surface and 2' shoulders (template 3) to 16 units, or a total width of 14', including a 10' travel surface, with 2' shoulders on either side and pullouts at 150' intervals in accordance with (template 4).
- B. A total roadway width of 24', including an 18' paved surface and 3' shoulders in accordance with (template 3) for roads serving 16 or more dwellings, or one or more non-residential units.
- C. Grades shall be the same as for one dwelling roads/driveway identified above.
- D. If the length of the driveway is less than 50' then A and B above does not apply.
- E. If the length exceeds 150', a turnaround shall be provided in accordance with (template 1 or 2).

Driveway approaches and private road intersections with public roads shall meet the following:

- A. Driveway approaches and private road intersections with public roads must comply with (template 5).

TEMPLATE 1 – Cul-de-sac

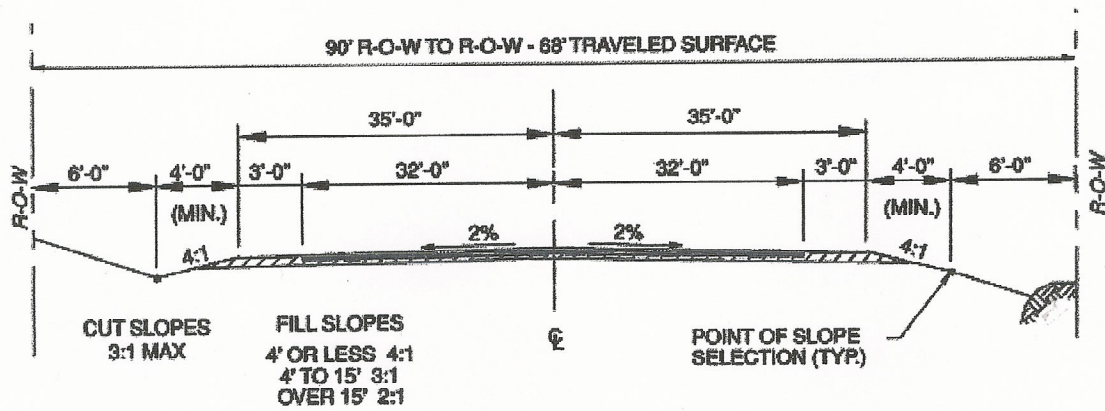
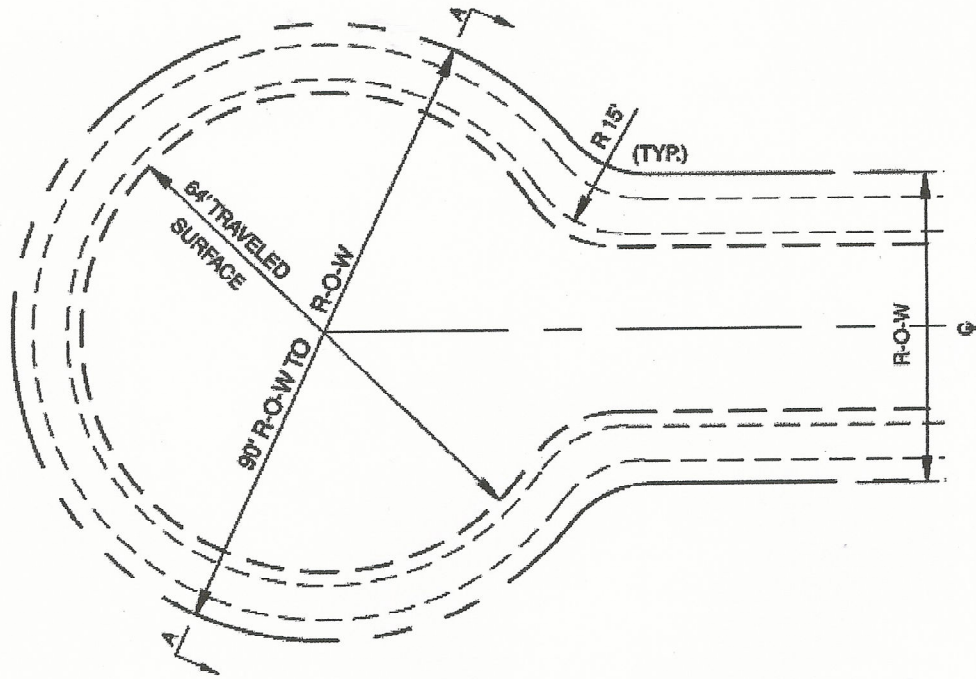

TEMPLATE 2 – Hammerhead Turnaround

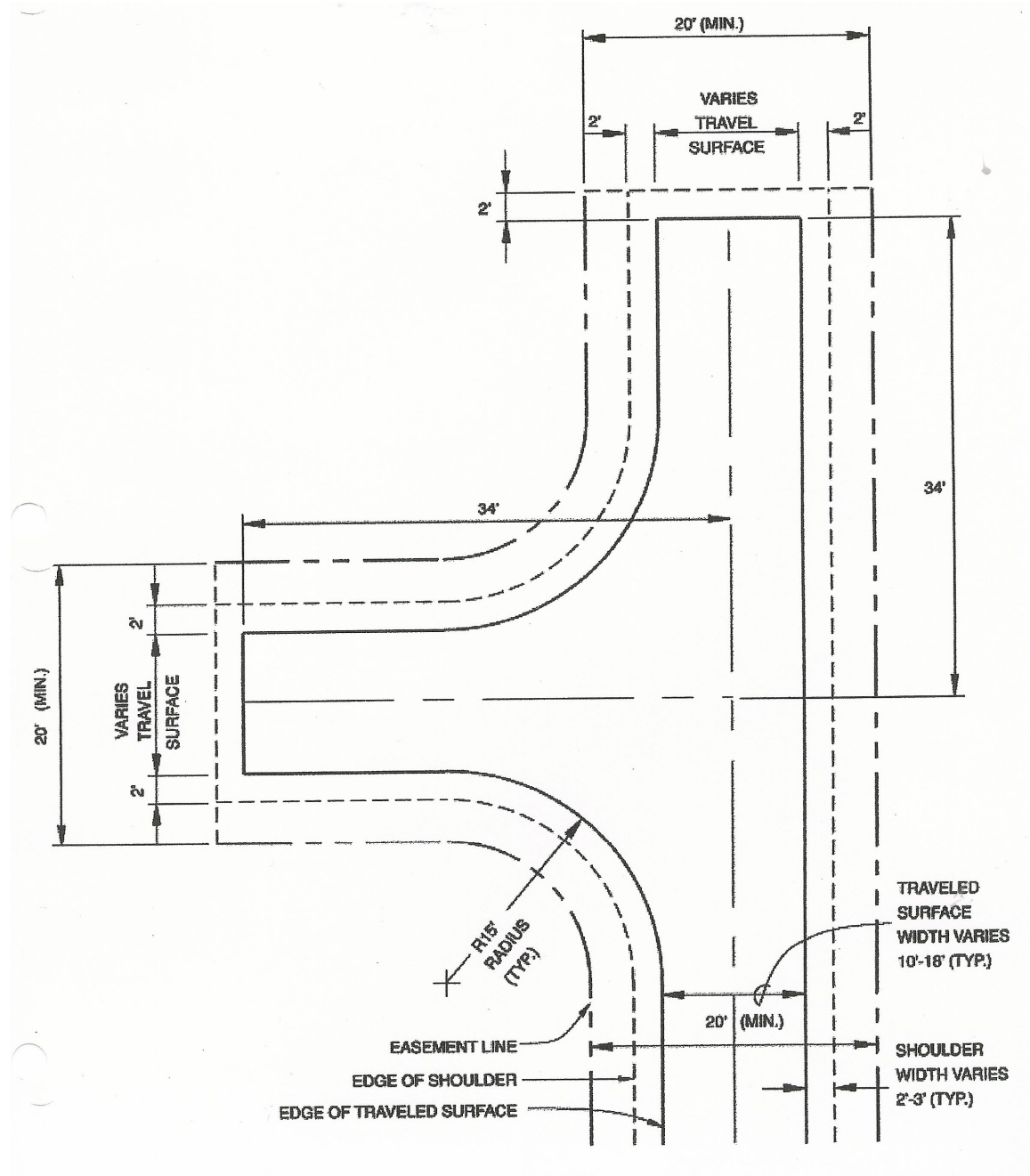

TEMPLATE 3 – Private Road

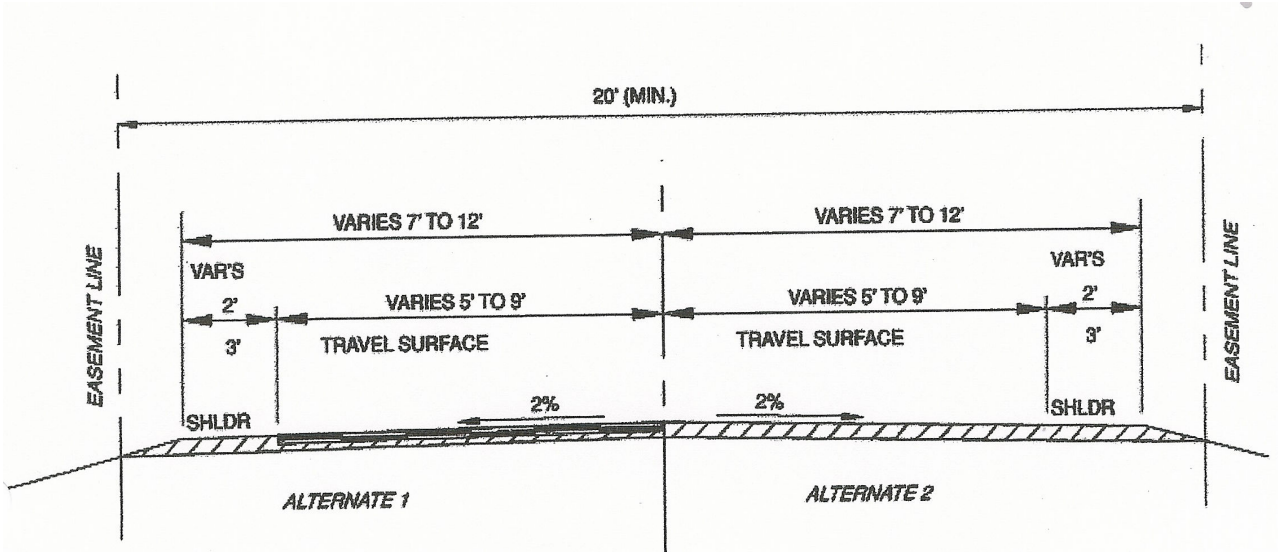

TEMPLATE 4 – Pull Out for Private Road

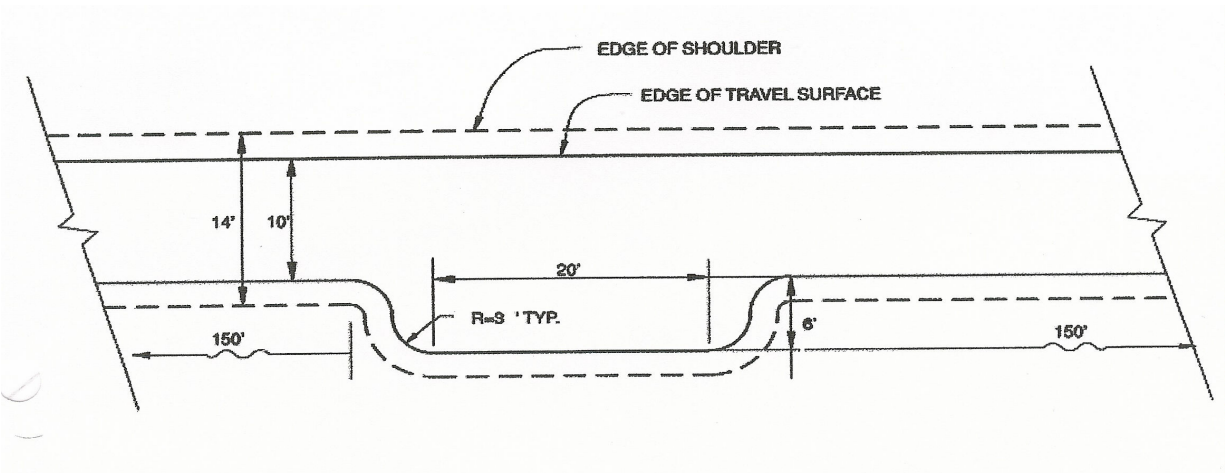

TEMPLATE 5 – Driveway Approaches for Roads

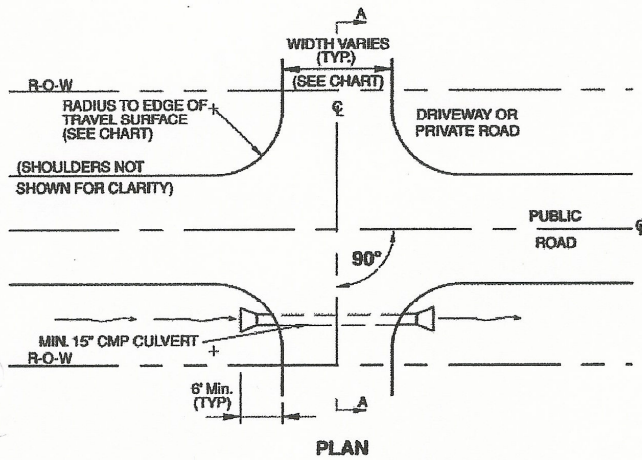

DRIVEWAYS AND PRIVATE ROADS SHALL INTERSECT WITH PUBLIC ROADS AT RIGHT (90°) ANGLES OR AS NEARLY AT RIGHT ANGLES AS POSSIBLE FOR A DISTANCE OF:

- 25' FROM THE TRAVEL SURFACE OR WITHIN THE R-O-W (WHICHEVER IS GREATER) WHEN INTERSECTING WITH AN ARTERIAL ROAD, OR
- 15' FROM THE TRAVEL SURFACE OR WITHIN THE R-O-W (WHICHEVER IS GREATER) WHEN INTERSECTING WITH A COLLECTOR OR LOCAL ROAD.

	TRAVEL SURFACE	
	WIDTH (FEET)	RADIUS (FEET)
DRIVEWAY	10	10
PRIVATE ROAD	16-18	15

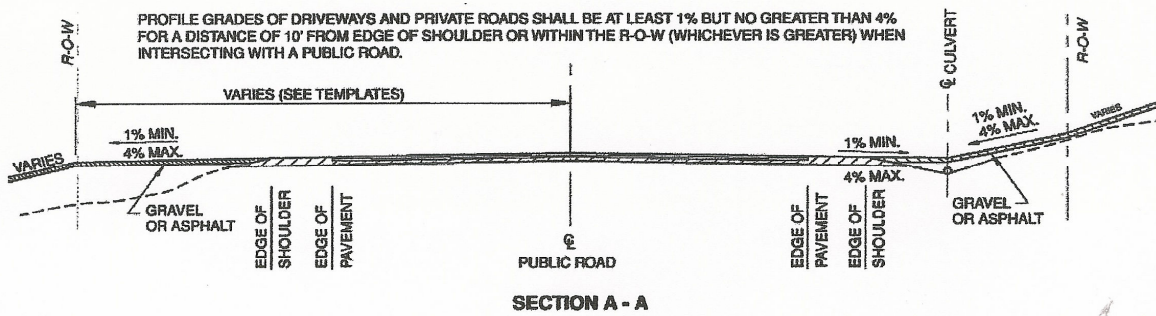

APPENDIX H – Spirit Mountain Ranch Triage

STRUCTURE TRIAGE

Triage is the determination of priorities for action during an emergency. This describes a concise decision making process that will be used if/when a wildfire threatens multiple structures simultaneously within Spirit Mountain Ranch. It will be done rapidly and on the move.

Structure:

Roof Type?

Debris on Roof?

Propane Tank?

Siding?

Fire Brand Traps?

Flammable Clutter?

Defensible Space:

Is There Any?

Water Supply?

Adjacent Fuel Type ?

Access?

Current & Expected Fire Behavior?

Available Firefighting Resources?

Firefighter Safety:

Escape Routes?

Safety Zones ?

Quickly determine the status of each threatened structure and make decisions!

Clearly communicate the priorities and firefighter evacuation criteria!

Be ready to live with your decisions, they will be second guessed after the threat is over.

Your first priority is to live to fight fire another day!!

APPENDIX I-Subdivision Fire Hazard Ratings

APPENDIX J – Definition of Terms

Appropriate Management Response (AMR) - Specific actions taken in response to a wildland fire to implement protection and fire use objectives identified by appropriate government agency. AMR allows for a full range of strategies to be applied, from an intense full suppression response to wildland fire use. The first response decision to be made is whether to have a suppression oriented response or to allow the fire to burn for predetermined benefits.

Confinement Response- The suppression-orientated strategy employed in appropriate management response where a fire perimeter is managed by a combination of direct and indirect actions and use of natural topographic features, fuels, and weather factors. These strategies and tactics could include perimeter control.

Defensible Space- Area around a structure where fuels and vegetation are treated, cleared or reduced to slow the spread of wildfire towards the structure. It also reduces the chance of a structure fire moving from the building to surrounding forest. Defensible space provides room for firefighters to do their jobs.

Disturbance- A discrete event, either natural or human induced, that causes a change in the existing condition of an ecological system.

Energy Release Component (ERC) - An index developed through the National Fire Danger Rating System. ERC then is an indicator of dryness in the fuel, is a fuel loading based rate that predicts how much energy f fire will produce both from its consumption of available fuel and through its residence time. ERC, and 1000 hour time lag fuel moisture has been used in dry climates to track seasonal drying trends.

Escape Fire Situation Analysis (EFSA) - If a wildfire has escaped initial attack EFSA is the process the agency administrator or acting uses to determine the best suppression strategy for achieving appropriate suppression that best meets resource objectives.

Fire Management Plan (FMP) - A strategic plan that defines a program to manage wildland and prescribed fires. The plan could be supplemented by operational plans, prescribed fire plans, hazardous fuels reduction, and prevention plans.

Fire Use - The combination of wildland fire use and prescribed fire application to meet specific resource and landowner objectives.

Fuel Treatment - Programmed and contracted to reduce or change fuel loading or type on a site. Can be accomplished by mechanical, chemical or fire use.

Full Response - A suppression response action that can include: control lines surrounding the entire perimeter, (hot spot and cold trail may be considered completed line) including any spot fires, protection of interior islands, burn-out of fuels adjacent to control lines and mop-up to a standard adequate to hold under high fire intensity conditions. Full response objectives are based on safe yet aggressive approach to achieve containment of the fire by the beginning of the next burn period. Fire behavior may dictate, at least temporarily, the utilization of natural barriers or indirect strategies. These strategies and tactics would include direct control.

Haines Index - Lower atmosphere stability index (LASI) developed by Donald Haines. The index relies on two variables: dryness and stability/instability. On a scale of six, three points are given to dryness and three to the stability or instability of the atmosphere. Both these variables have a pronounced affect on extreme fire behavior. In the scaling, a 6 is extreme, 5 are high, 4 are moderate, while 3 to 1 are low.

Initial Attack - An aggressive suppression action consistent with firefighter and public safety and values to be protected.

Initial Management Area (IMA) - The size of an IMA may be adjusted based on fire behavior predictions, weather forecasts, site analysis and risk assessment. The IMA becomes fixed as an MMA once a wildland fire is placed under a stage III implementation plan.

Insurance Services Office (ISO) Rating - An overall fire services rating developed for use in determining insurance premiums for residential and commercial property. Factors such as fire alarm systems, equipment, training, availability of water (hydrants), etc. are used to develop the rating. The rating is on a scale of class 1 to class 10, with 1 providing the best public protection and 10 providing the lowest public protection. See www.iso.com for more details.

Maximum Management Area (MMA) - The firm limits of management capability to accommodate the social, political, and resource impacts of a wildland fire. Once an approved Wildland Fire Use plan is established the MMA is fixed and not subject to change. If MMA determination is exceeded, the fire will follow the Wildland Fire Situation Analysis (WFSA) process.

Mitigation Actions - Those on-the-ground activities that will serve to increase the defensibility of the Maximum Manageable Area (MMA); check, direct, or delay the spread of fire, and minimize threats to life, property, and resources. Mitigation actions may include mechanical and physical non-fire tasks, specific fire applications, and limited suppression actions. These actions will be used to construct fire lines, reduce excessive fuel concentrations, reduce vertical fuel, and create black lines.

POL – Stands for “Products Other than Logs” thinning to harvest poles and posts and firewood.

Polygon - A planning sub-unit within a fire planning area that represents similar resource values and landowners objectives, fuel conditions with associated fire behavior, Social/Political concerns and economic considerations. Polygons are categorized as A, B, C, and D areas.

Preparedness - Activities that lead to a safe, efficient, and cost-effective fire management program in support of land and owners management objectives through appropriate planning and coordination.

Prescribed Fire - Any fire ignited by management actions to meet specific objectives. A written, approved prescribed fire plan must exist prior to ignition.

Prescribed Fire Plan - A plan required for each fire application ignited by management. It must be prepared by qualified personnel and approved by the appropriate agency administrator prior to implementation. Each plan will follow specific direction and must include critical elements and how to mitigate each element.

Prescription Guidelines - guidelines used to show upper and lower reaches of a prescription.

Spread Component (SC) - An index developed through the National Fire Danger Rating System. The index provides predicted rate of spread of a fire (in chains per hour) from inputted information on the fuel complex and weather information collected from a local Remote Automated Weather System (RAWS) site.

Suppression Constraints - A limitation placed on suppression forces to minimize adverse affects to the environment due to fire suppression activities. An example would be restricting the use of heavy equipment in certain areas.

Suppression Oriented Response - A range of responses to a wildland fire, which range from full response to confinement of the fire. It may also include periodically checking fire status and fire behavior.

TSI – Stands for “Timber Stand Improvement” thinning to stimulate growth and improve residual tree health

Wildfire - An unwanted wildland fire.

Wildland Fire - Any nonstructural fire, other than prescribed fire, that occurs in the wildland. This term encompasses fires previously called both wildfires and prescribed natural fires.

Wildland Fire Implementation Plan (WFIP) - A progressively developed assessment and operational management plan that documents the analysis and selection of strategies and describes the appropriate management response for a wildland fire being managed for resource benefit.

Wildland Fire Situation Analysis (WFSA) - A decision-making process that evaluates alternative management strategies against selected safety, environmental, social, economic, political, and resource management objectives.

APPENDIX K – References and Publications

Anderson, Hal E. 1982. Aids to determining fuel Models for Estimating fire Behavior. USDA Forest Service. General Technical Report INT-122, 22 p. Intermountain Forest and Range Experiment Station, Utah, 84401.

Andrews, Patricia; Bevins, Collin; and Seli, Robert. BehavePlus fire modeling system User's Guide. USDA forest Service. General Technical Report RMRS-GTR-106WWW. Rocky Mountain Research Station.

Cohen, J.. 1999. Reducing Wildland Fire Threat to Homes: Where and How Much. Rocky Mountain Research Station. USFS.

Dennis F.C. 1999. Fire Resistant Landscaping. No. 6.303 Natural Resource Series, Colorado State University Cooperative Extension.

Dennis F.C. 1999. Forest Home fire safety. No. 6.304 Natural Resource Series, Colorado State University Cooperative Extension.

Dennis F.C. 2002. Firewise Plant Materials. No. 6.305 Natural Resource Series, Colorado State University Cooperative Extension.

Dennis F.C. 2003. Creating Wildfire-Defensible Zones. No. 6.302 Natural Resource Series, Colorado State University Cooperative Extension.

Dennis F.C. 2005. Fuelbreak Guidelines for Forested Subdivisions & Communities. Colorado State Forest Service.

Graham, Russell. 2003. Editor. Hayman Fire Case Study: summary. USDA Forest Service. General Technical Report RMRE-GTR-115. Rocky Mountain Research Station.

Helms, John. 1998. The Dictionary of Forestry. Society of American Foresters.

International Urban-Wildland Interface Code. 2003. International Code Council, INC.

Publications

- Creating Wildfire-Defensible Zones, no 6.302, F.C. Dennis, CSU Cooperative Extension, 5/2003
- Fire Resistant Landscaping, no 6.303, F.C. Dennis, CSU Cooperative Extension, 5/1999
- Forest Home Fire Safety, no 6.304, F.C. Dennis, CSU Cooperative Extension, 5/1999
- FireWise Plant Materials, no 6.305, F.C. Dennis, CSU Cooperative Extension, 11/2003
- Grass Seed Mixes to Reduce Wildfire Hazards, no 6.306, F.C. Dennis, CSU Cooperative Extension, 10/2003
- Vegetative Recovery After Wildfire, no 6.307, R. Moench, CSU Cooperative Extension, 10/2003
- Soil Erosion Control After Wildfire, no 6.308, R. Moench & J. Fusaro, CSU Cooperative Extension, 10/2003
- Insects and Diseases Associated with Forest Fires, no 6.309, D. Leatherman, CSU Cooperative Extension, 12/2002
- Fuelbreak Guidelines for Forested Subdivisions, F. C. Dennis, CSFS/CSU, 2005

Appendix L: Defensible Space Maintenance & Gambel Oak

In general, residents in the Spirit Mountain Ranch have made significant efforts to reduce fuels around their structures. They have and are continuing to thin trees, removing the lower limbs (ladder fuels) and attempting to clear the Gambel oak. The heavy woody material has been cut and stacked for firewood and the lighter material has been chipped and spread on the ground. While their efforts in reducing fuels provided by pinyon, juniper, Gambel oak and ponderosa pine have produced a more defensible space around their homes, clearings in the Gambel oak are more troublesome. Residents we talked to complained about the aggressive sprouting that occurs after clearing the oak and the continual clearing process that is necessary to hold the oak brush in check.

Gambel oak is a native plant that is naturally associated with pinyon-juniper and ponderosa pine forests in southern Colorado. It is a deciduous shrub that is quite adaptable and easily finds a niche in the under story of these forest types as well as in relatively pure stands. It thrives on steep slopes as well as more moderate sites and on a variety of coarse and medium textured soils. Gambel oak grows in clumps that are interconnected by an extensive root system that is characterized by both shallow rhizomes and deep-feeding roots. These rhizomes send up numerous sprouts when the mature stems are removed or when injury occurs.

Eradication of Gambel oak is rare by any method and without complete kill prolific sprouting may occur from roots, rhizomes and basal stems. Treated areas usually assume a thickets like appearance several years after the initial work (1). Numerous chemicals and combinations of chemicals have been used with limited success to control Gambel oak. Mechanical treatment, such as cutting stems and burning, are common methods of removing oak brush but it usually results in aggressive sprouting. Biological control of sprouts with repeated browsing by goats has proven to be an effective means of near elimination of oak sprouts, however browsing by goats is not considered to be practical in all situations. Goats prefer Gambel oak leaves for forage and after several years of repeatedly defoliating the oak during the period before the oak leaves reach full growth most of the sprouts are killed (1).

On the Spirit Mountain Ranch where Gambel oak has been cut and sprouting is occurring, the most likely treatment is one that repeatedly defoliates the oak during mid summer. The positive effect of this repeated defoliation has been demonstrated using herbicides (1), prescribed burning (2), and browsing by goats (1). Defoliation may be accomplished by:

- > mowing or chopping sprouts during mid summer
- > using goats to browse the leaves and young shoots during mid-summer
- > using an approved herbicide following instructions on the label kill or defoliate the sprouts during mid summer which coincides with the time when leaf growth is reaching maximum. Some herbicides are restricted and require an Applicator's License to use. It is

suggested that the Las Animas County Weed Specialist be contacted for local advice and guidance prior to using a herbicide (719-846-4468).

Recently a herbicide called Garlon 3A put out by Dow AgroScience has become available. The active ingredient is triclopyr which is in the family of growth regulators. It causes the plant to grow uncontrollably and it shows promise of being useful in controlling Gambel oak. It is labeled for forestry uses, is sprayed on foliage, bark and cut stumps and becomes water fast in a couple of hours. It is particularly good in controlling resprouting that is one of the primary problems with controlling Gambel oak. It appears to be appropriate for use on Spirit Mountain Ranch and those using the product are reporting successful applications.

New Mexico State University Cooperative Extension Service Circular 597 contains a list of herbicides for controlling Gambel oak and other undesirable brush species (3). Table 1 contains an excerpt from Circular 597.

Table 1. Herbicides for controlling Gambel oak

Trade name and product rate/acre	Herbicide common name and active ingredients	Spray volume per acre or individual plant	Time of application	Remarks
Spike 20P ¼ oz per 22 sq ft when treating clump or thicket. p	Tebuthiuron	Individual plant treatment. Anytime of year	Optimum is prior to rainy season	Distribute uniformly under canopy. Do not apply to frozen or snow covered ground
OR Spike 20P 3 ¾ to 7 ½ lbs. pellets	OR Tebuthiuron ¾ to 1 ½ lb.	Aerial broadcast	Anytime during the year. Optimum is prior to rainy season.	Distribute uniformly under canopy. Do not apply to frozen or snow covered ground
OR Velpar L 2-4 ml per 33 sq ft of canopy diameter	OR Hexazinone	Individual plant treatment. Anytime during year	Optimum is prior to growing season	Apply undiluted Velpar L to soil within 3 ft of stem base. Use exact delivery handgun applicator. Do not apply to frozen ground. Do not use on clay soil.
OR Arsenal 1 gal per 100 gal water	OR Imazapyr 2 lb per 100 gal water with 0.25% surfactant	Individual plant treatment or ground application	Anytime during growing season when growing conditions are good.	Spray to wet.

Bibliography

- (1) Engle, D.M., C.D. Bonham, and L.E. Bartel. 1983. Ecological characteristics and control of Gambel oak. J. Range Manage 36(3)
- (2) Harrington, M.E. 1989. Gambel oak root carbohydrates in roots of Gambel oak sprouts following herbicide treatment. J. Range Manage 42(6)
- (3) Duncan, K.W., K.C. McDaniel and M.J. Renz. 2005. Chemical

weed and brush control for New Mexico rangelands. New Mexico State University Cooperative Extension Service Circular 597. 18p.

	A	B	C	D	E	F	G	H	I	J
1	Spirit Mountain Ranch Triage									
2										
3	Road	Address	Lot No.	Drive Lat: N 37	Drive Lon: W 104.	Length (ft)	Width (ft)	Grade (%)	Turnround	Driveway fuels
4	Spirit Mountain Drive	21750	10	32532	76525	2167	12	7	good	open PJ-PP_G
5	Spirit Mountain Drive		12	32842	76634	1267	10	10	good	heavy PJ-PP
6	CR 43.6	22000	14	32826	75478	2562	10	7	good	open PJ, grass,
7	CR 43.6	23251	15	33088	75488	521	10	1	good	grass
8	Spirit Mountain Drive	22300	17	32059	77717	1267	10	5	fair	PP-O
9	Eagle Court	21139	18	31625	77919	363	10	2	good	PJ-PP
10	CR 46.0	22750	21	31347	76506	1426	10	6	fair	short 8% pitch
11	CR 46.0	21441	22	31231	76839	1373	12	9	good	9% but graveled
12	Eagle Court	22200	26	31699	78098	450	10	2	good	PJ med
13	CR 46.0	20801	27	30942	78235	898	10	1	good	thinned
14	CR 46.0	21270	30	31125	78719	1426	10	12	good	PJ-O but cleared
15	CR 46.0	21000	31	30949	78284	2957	10	7	good	no surfacing, ruts
16	Spirit Mountain Drive	21011	35	32515	77415	100	10	0	good	PJ med
17	Spirit Mountain Place	21481	37	33066	76828	792	10	2	good	heavy PP,PJ,O
18	CR 43.6		43	33729	76269	250	12	3	good	grass
19	Spirit Mountain Drive	22460	2	31717	76520	898	10	3	fair	last 50 ft is 10%
20	Spirit Mountain Drive		4	31958	76920	1584	10	4	poor	PJ-PP
21	Spirit Mountain Drive	21130	6	32489	77580	283	12	4	good	heavy PJ,O
22	Spirit Mountain Drive	21500	8	32641	76996	1425	10	3	fair	PJ -O
23	Eagle Court		23	31602	77892	1742	10	4	good	heavy PJ fuel
24	CR 46.0		25	30879	77287	100	12	0	poor	abandoned
25	CR 46.0	21250	29	31100	78648	427	10	4	good	open grass, PJ
26	Eagle Court		33	32321	78335	633	10	3	fair	PJ-PP
27	Spirit Mountain Drive	23119	34	32446	77939	242	12	0	good	open PJ
28	Spirit Mountain Drive	21325	36	32610	77193	375	10	1	good	heavy PJ,O
29	Spirit Mountain Place		39	33153	77193	450	10	0	poor	PJ-PP
30	Spirit Mountain Drive	23600	42	33218	76060	442	10	5	good	PP
31	Spirit Mountain Drive		1							
32	Spirit Mountain Drive		3							
33	Spirit Mountain Drive		5							
34	Spirit Mountain Drive		7							
35	Spirit Mountain Drive		9	32532	76525					
36	Spirit Mountain Drive		11	32532	76525					
37	Spirit Mountain Drive		13							
38	Spirit Mountain Drive		16							
39	Spirit Mountain Drive	21490	19	31928	77190					
40	Spirit Mountain Drive		20							

	A	B	C	D	E	F	G	H	I	J
41	CR 46.0		24	31085	77048					
42	CR 46.0		28	30949	78284					
43	Eagle Court		32	31863	78673					
44	Spirit Mountain Place		38							
45	Spirit Mountain Place		40	33106	77048					
46	Spirit Mountain Place		41							

	U
1	
2	
3	Notes
4	excellent def space demo, good thinning, metal roof, stucco,wood decks,
5	locked gate, Google view
6	locked gate, structure is east of structure on lot 12
7	room for staging area or helispot metal room, new structure
8	no well, wood siding, comp roof, wood deck, good defensible space work,
9	cistern, well, stucco, comp roof
10	water source 11 gpm well, good place for helispot and staging,
11	possible helispot, 3 gpm well
12	loop drive,metal roof, stucco-brick, wood deck, med PJ fuel on slope below home, barn separate
13	thinning in defensible space, wood deck, metal roof & siding, owns old house on Lot 25
14	locked gate, Google view
15	top of highest hill, PJ, PP on slopes below structure, difficult access rd, metal, wood siding
16	metal bldg, heavy PP-PJO fuel on slope 30 yds below structure
17	thin fuel along driveway, metal roof, stucco
18	no address, home above horse barn, metal roof, wood siding,
19	high wood deck, wood siding, few trees close to structure
20	unimproved driveway to cabin, heavy fuel along long drive, Google Earth view
21	under construction, pad poured, needs defensible space thinning
22	downslope PP fuel, good defensible space, well, cystem,metal roof, stucco,
23	locked gate, viewed with binocs, uncertain on survivability, defensibility, Google view
24	abandoned historic structures belongs to same owner as lot 27
25	firewood on deck, comp roof, wood siding,
26	need to thin along driveway, comp roof, comp siding, wood deck, fuel on slope below, med PP-O
27	heavy downslope PJ fuel, wood siding, metal roof,
28	metal bldg, heavy PP-PJO fuel on slope below structure
29	under construction,off culdisac 45 ft dia, metal roof, non combustible siding
30	heavy downslope PP fuel, dead PP piles, well 2.5 gpm depth 340',cystem, metal roof, helispot
31	
32	
33	
34	
35	possible safety zone
36	
37	
38	
39	address sign, undeveloped
40	

	U
41	drive exits off CR 46
42	drive to lot 31 passes through lot 28, fire control cistern at jct of CR 46 and lot 28 driveway
43	gas well entrance
44	
45	Spirit Mountain Place cul de sac, inadequate turn radius
46	

APPENDIX M–Spirit Mountain Mountain Ranch Triage Spread Sheet

Appendix N_Spirit Mountain Ranch Open House, August 2, 2008

An Open House meeting was conducted at 9:30 am August 2, 2008 at the Spanish Peaks Inn with 22 persons attending. The meeting concluded at 12:15 pm. Donnie Sparks representing Land Stewardship Associates presented the Draft Spirit Mountain Ranch CWPP using a Power Point presentation and responded to questions during the presentation. C.K. Morey and Dave Skoberg representing Colorado State Forest Service attended and provided significant insight to the discussions.

Attendees signed an attendance list and a questionnaire was passed out to gather information from individuals. Only 6 attendees completed the questionnaire. The results are summarized below.

The following issues were raised as questions and were discussed during the presentation.

- Las Animas County is one of the poorest in Colorado.
- Neighbors within a mile of the boundary of SMR can be included in mitigation projects.
- Nothing has changed since the Reverse 911 was tried unsuccessfully and the sheriff still has too many jobs. A paid full time Emergency Manager is needed.
- 2009 Grant Applications are due to CSFS by August 29, 2008. Dave Skoberg agreed to help with grant writing.
- Home sprinklers are available that will apply a gel based foam for \$400 to \$500. After 4-6 hours it can be rehydrated with a water spray.
- The cistern at Eagle Court has a 45 degree stinger that needs to be replaced with a straight 3 inch PVC pipe to allow engines to draft water.
- A new source of water for fire control is available at a spring fed pond on the DuLcevie Ranch
- Materials for a dry hydrant usually cost between \$500 and \$1,000.
- Water for fire control is very short in the Aguilar area now. Fire Department is required to use a rusty well out of town.
- One individual indicated that there are only 15 volunteers for the FD.
- The need for a county-wide CWPP was discussed and the Trinidad Lakes subdivision is apparently seeking a CWPP for their subdivision.
- Wildland Urban Interface (WUI) grants require a cost share.
- Sources for Grant moneys include: Senate Bill 71, Senate Bill 51 which was extended for 5 years, 2008 Farm Bill and Emergency

Management Program Grants. It was suggested that Grant applications for 2010 should be started now. Dave Skoberg is very knowledgeable if further information is needed.

Summary of Questionnaire Responses

A. Do you live in, or own property in an area vulnerable to wildfire?
6 (100%)-Yes, 0- No

B. What is your primary concern relative to wildfire in your neighborhood?

- A wildfire might occur
- Brush control
- Absentee owners do no mitigation
- Community fire protection manpower

C. If you have structures on your property do you think they will survive a wildfire in their close proximity? 6 (100%) Yes , 0 No

D. Are you familiar with the term "Survivable Space" when it comes to structures and wildfires? 6 (100%) Yes, 0 No.

E. Are you willing to expend the labor or money to improve the probability that your structures will survive a wildland fire? 5 (83%) Yes, 1 (17%) No.

F. Are you interested in applying for a grant to defray some of the cost of improving survivable space on your property? 5 (83%) Yes, 1 (17%) No.

G. Would you like more information on preparing your structures for the inevitable wild fire? 5 (83%) Yes, 1 (17%) No. If so what format do you prefer?

2 (33 %) Brochures and pamphlets

3 (50 %) Formal Workshop

4 (67 %) On site consultation with a person familiar with

FireWise concepts?

H. What suggestions do you have to reduce your community's vulnerability to wildfires?

- Get county government involved
- Get help with chipping brush and chemicals for spraying
- Inform absentee owners
- Make homeowners accountable for fire livable space.

Fire Hazard and Mitigation - Spirit Mountain Ranch, Las Animas County, CO

Legend

- ▲ Structures
- ☼ Pioneer Gas Well
- Ⓜ Water Source
- Ⓜ Proposed Water Source
- ▨ Proposed Fuel Break (300 feet)
- ▬ Evacuation Routes
- - - Well Access
- ⋯ Driveways
- ▭ Spirit Mountain Ranch Lots

Fire Hazard (Based on Flame Length)

- ▭ Moderate
- ▭ High

8/11/2008

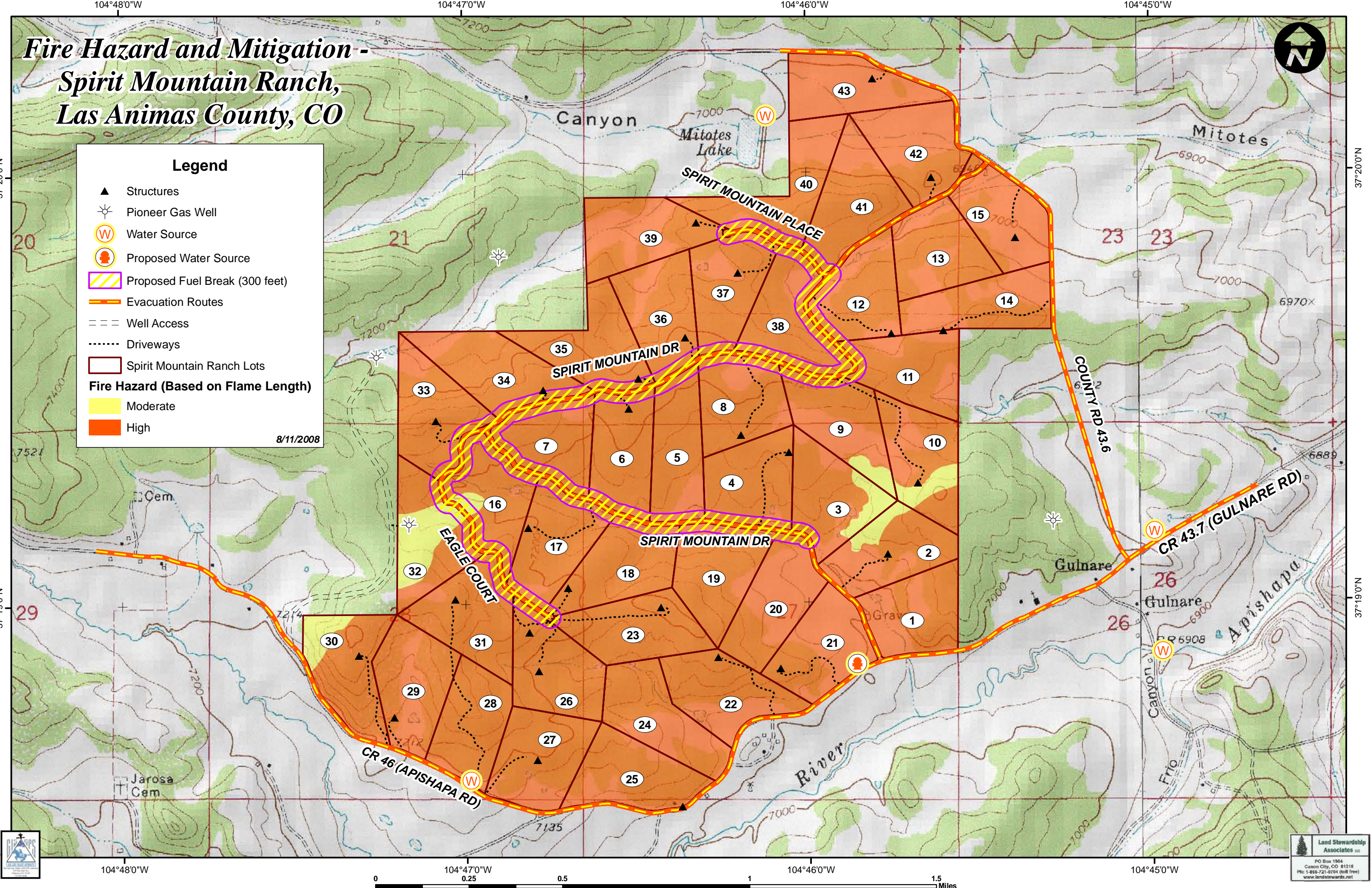

Fuel Model - Spirit Mountain Ranch, Las Animas County, CO



Legend

- ▲ Structures
- Well Access
- Driveways
- Spirit Mountain Ranch Lots

Fuel Model

Light Yellow	1
Yellow	1/6
Orange	6
Dark Orange	6/9
Red	9

8/11/2008

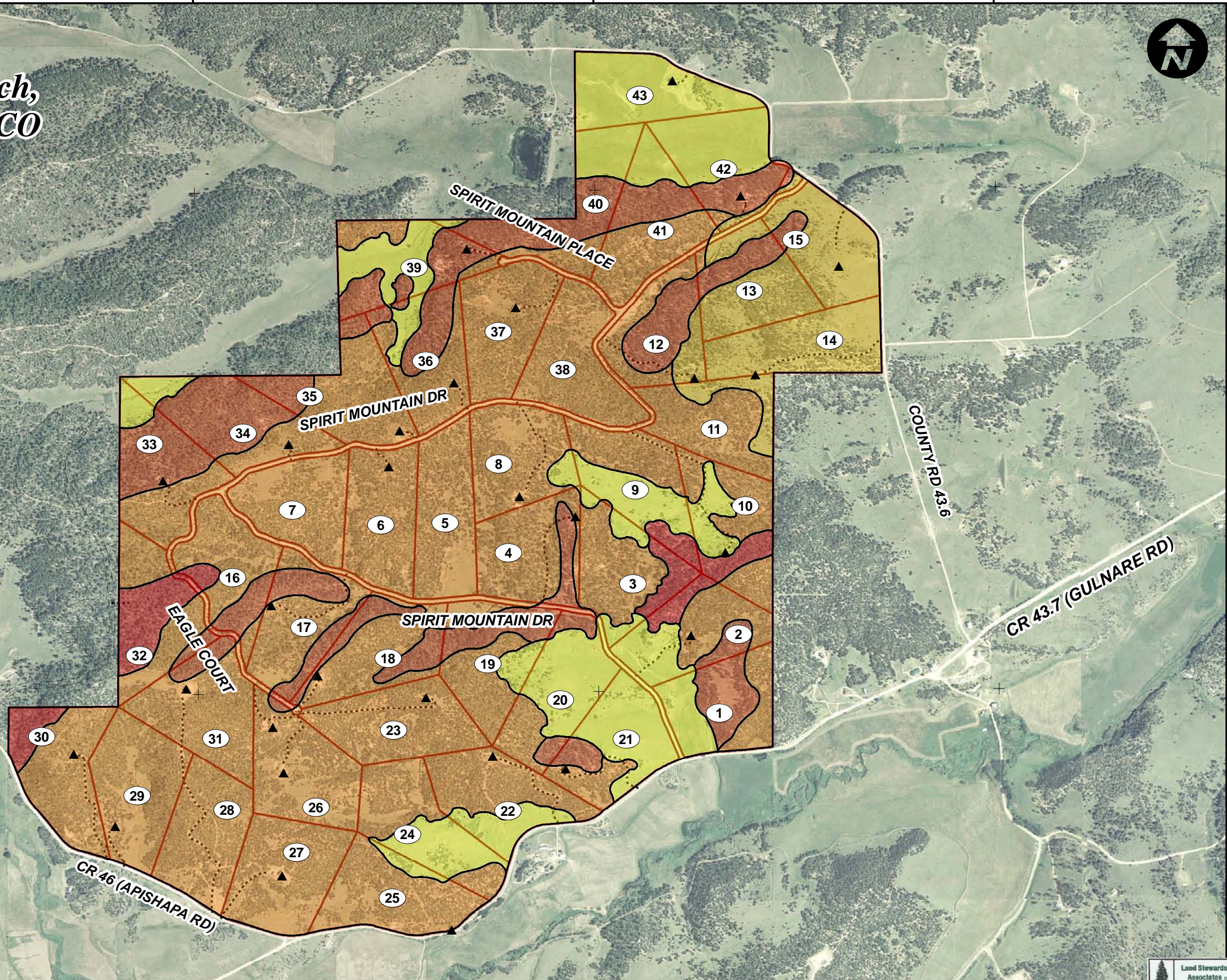

Land Stewardship Associates LLC
 PO Box 1904
 Canon City, CO 81215
 Ph: 1-888-721-0704 (toll free)
 www.landstewardsonline.com

Triage & Fire Control Features - Spirit Mountain Ranch, Las Animas County, CO



Legend

- ▲ Surrounding Structures
- ☼ Pioneer Gas Well
- Driveway Entrance
- Well Access
- Driveways

Structures rated for Survivability

- Y YES
- N NO
- Spirit Mountain Ranch Lots (with lot numbers)

Fire Control Features

- H Helispot
- SZ Safety Zone
- S Staging
- W Water Source

8/11/2008

37°20'0"N
37°19'0"N

37°20'0"N
37°19'0"N

104°48'0"W 104°47'0"W 104°46'0"W 104°45'0"W

104°48'0"W 104°47'0"W 104°46'0"W 104°45'0"W

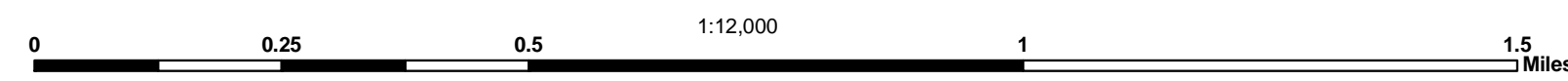

Land Stewardship Associates LLC
 PO Box 1904
 Canon City, CO 81215
 Ph: 1-866-721-0704 (toll free)
 www.landstewards.net

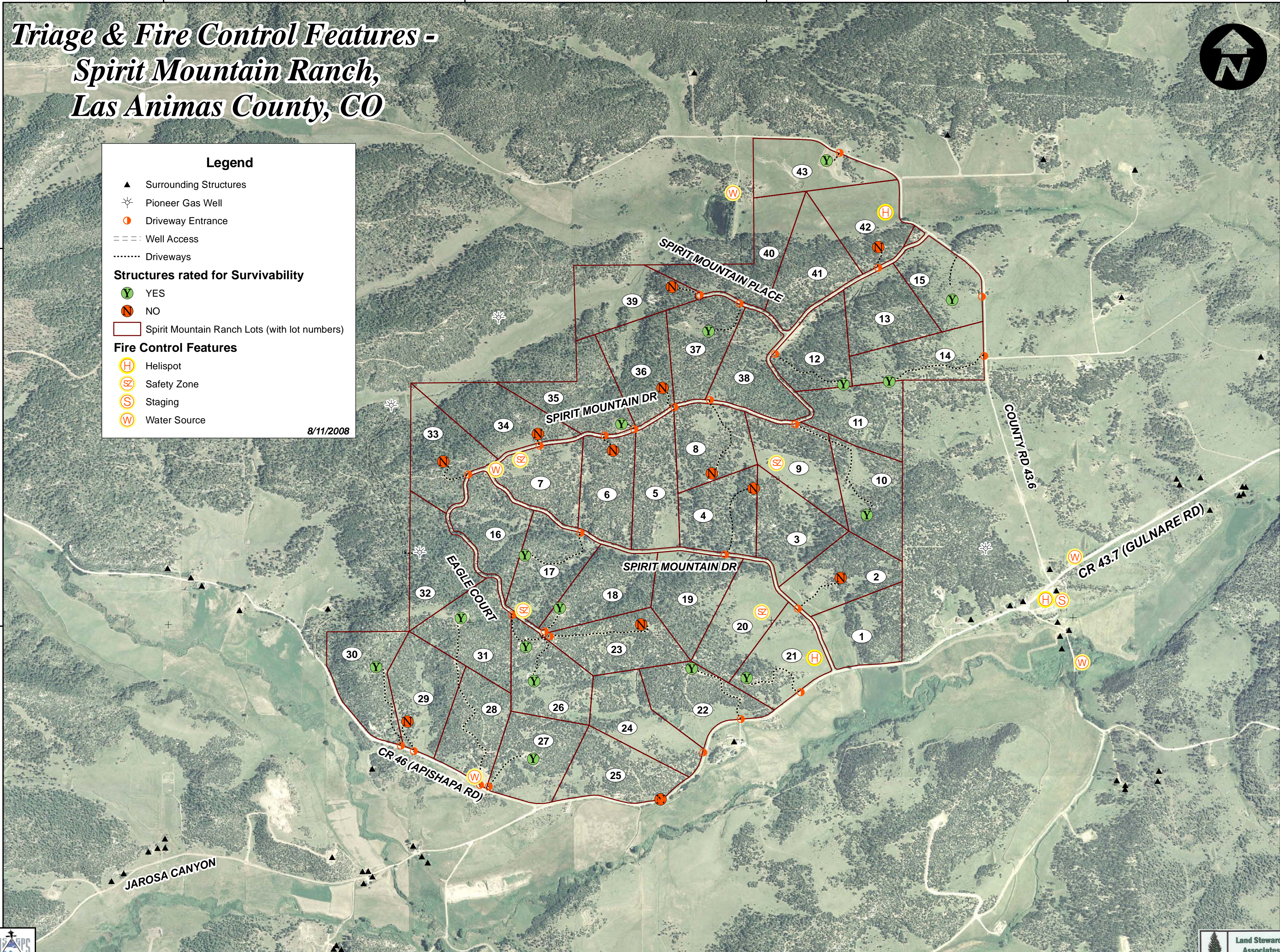

Triage & Fire Control Features - Spirit Mountain Ranch, Las Animas County, CO

Legend

- ▲ Surrounding Structures
- ☼ Pioneer Gas Well
- Driveway Entrance
- Well Access
- Driveways

Structures rated for Survivability

- Y YES
- N NO
- Spirit Mountain Ranch Lots (with lot numbers)

Fire Control Features

- H Helispot
- S Safety Zone
- S Staging
- W Water Source

8/11/2008



37°20'0"N

37°20'0"N

37°19'0"N

37°19'0"N

104°48'0"W

104°47'0"W

104°46'0"W

104°45'0"W

104°48'0"W

104°47'0"W

104°46'0"W

104°45'0"W

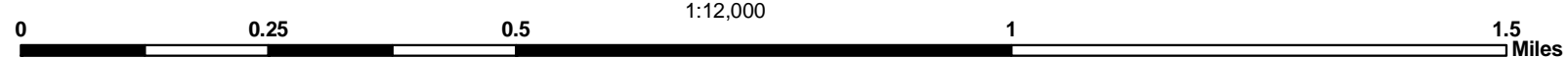

Land Stewardship Associates LLC
 PO Box 1904
 Canon City, CO 81215
 Ph: 1-866-721-0704 (toll free)
 www.landstewards.net













































































Shaded fuel break



Fuel Modle 9



Fuel Modle 1/9



Fuel Modle 9/6



Fuel Modle 6

